



# Ray Casting

COS 426, Spring 2015  
Princeton University

# Ray Casting

- The color of each pixel on the view plane depends on the radiance emanating along rays from visible surfaces in scene

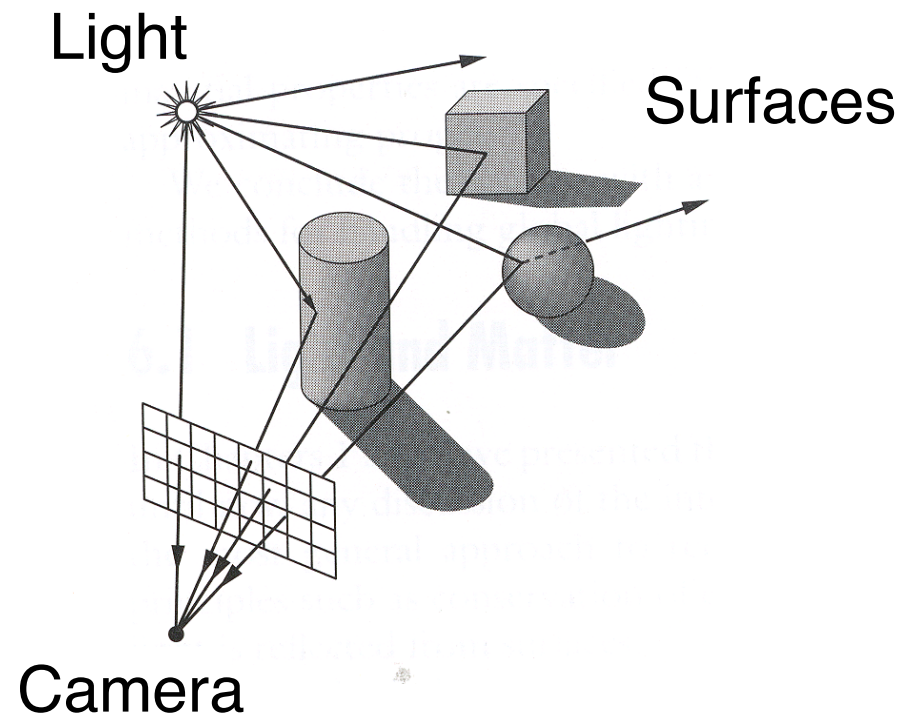

# Scene

- Scene has:
  - Scene graph with surface primitives
  - Set of lights
  - Camera

```
struct R3Scene {  
    R3Node *root;  
    vector<R3Light *> lights;  
    R3Camera camera;  
    R3Box bbox;  
    R3Rgb background;  
    R3Rgb ambient;  
};
```

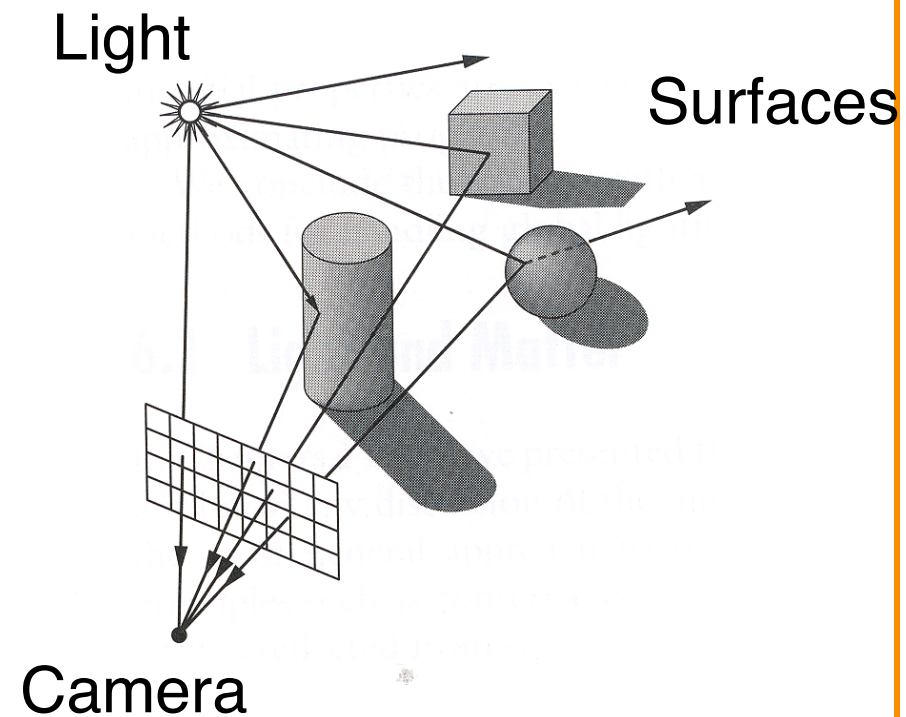

# Scene Graph

- Scene graph is hierarchy of nodes, each with:
  - Bounding box (in node's coordinate system)
  - Transformation (4x4 matrix)
  - Shape (mesh, sphere, ... or null)
  - Material (more on this later)

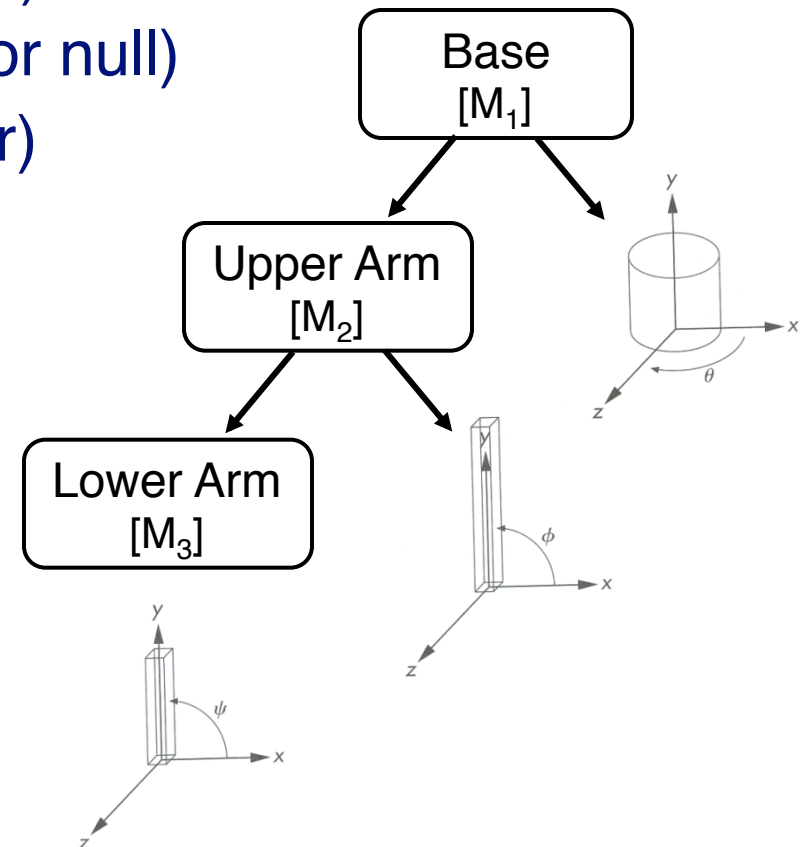
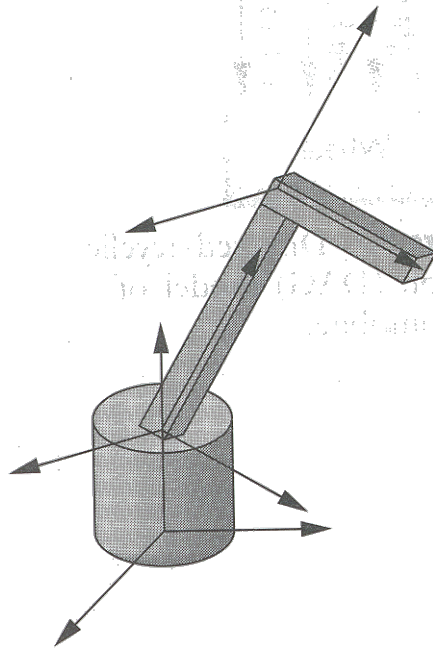

# Scene Graph



- Simple scene graph implementation:

```
struct R3Node {  
    struct R3Node *parent;  
    vector<struct R3Node *> children;  
    R3Shape *shape;  
    R3Matrix transformation;  
    R3Material *material;  
    R3Box bbox;  
};
```

```
struct R3Shape {  
    R3ShapeType type;  
    R3Box *box;  
    R3Sphere *sphere;  
    R3Cylinder *cylinder;  
    R3Cone *cone;  
    R3Mesh *mesh;  
};
```

# Ray Casting

- For each sample (pixel) ...
  - Construct ray from eye position through view plane
  - Compute radiance leaving first point of intersection between ray and scene

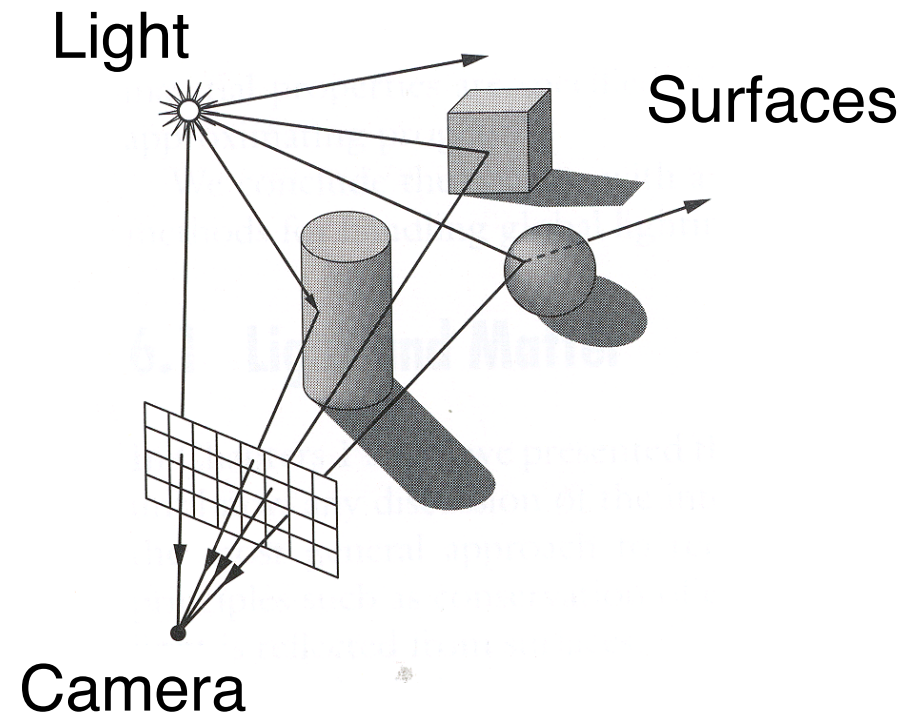

# Ray Casting



- Simple implementation:

```
R2Image *RayCast(R3Scene *scene, int width, int height)
{
    R2Image *image = new R2Image(width, height);
    for (int i = 0; i < width; i++) {
        for (int j = 0; j < height; j++) {
            R3Ray ray = ConstructRayThroughPixel(scene->camera, i, j);
            R3Rgb radiance = ComputeRadiance(scene, &ray);
            image->SetPixel(i, j, radiance);
        }
    }
    return image;
}
```

# Ray Casting



- Simple implementation:

```
R2Image *RayCast(R3Scene *scene, int width, int height)
{
    R2Image *image = new R2Image(width, height);
    for (int i = 0; i < width; i++) {
        for (int j = 0; j < height; j++) {
            R3Ray ray = ConstructRayThroughPixel(scene->camera, i, j);
            R3Rgb radiance = ComputeRadiance(scene, &ray);
            image->SetPixel(i, j, radiance);
        }
    }
    return image;
}
```



# Constructing Ray Through a Pixel

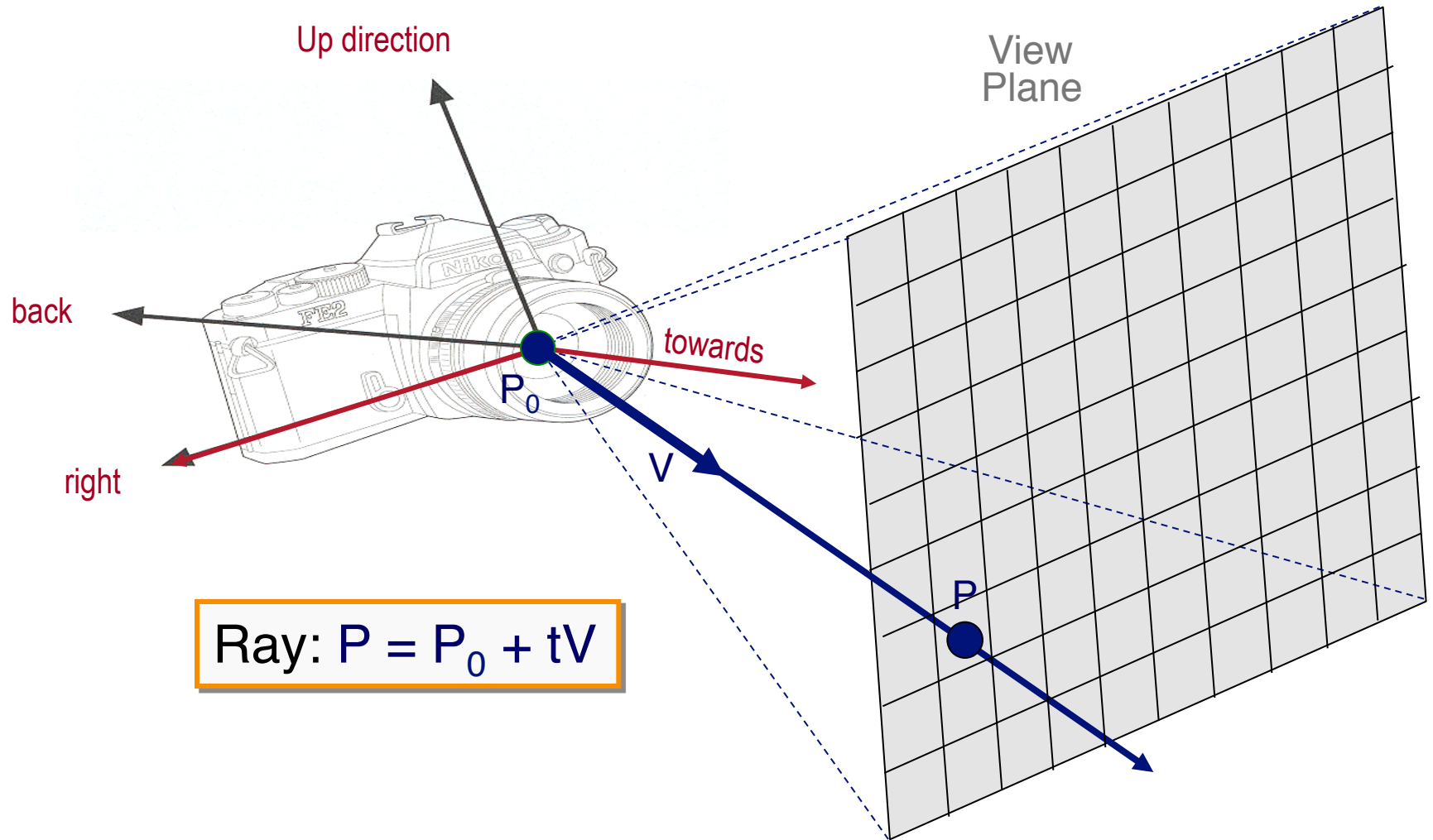

# Constructing Ray Through a Pixel



- 2D Example

$\Theta$  = frustum **half**-angle

$d$  = distance to view plane

$\text{right} = \text{towards} \times \text{up}$

$$P1 = P_0 + d * \text{towards} - d * \tan(\Theta) * \text{right}$$

$$P2 = P_0 + d * \text{towards} + d * \tan(\Theta) * \text{right}$$

$$P = P1 + ((i + 0.5) / \text{width}) * (P2 - P1)$$

$$V = (P - P_0) / \|P - P_0\|$$

( $d$  cancels out...)

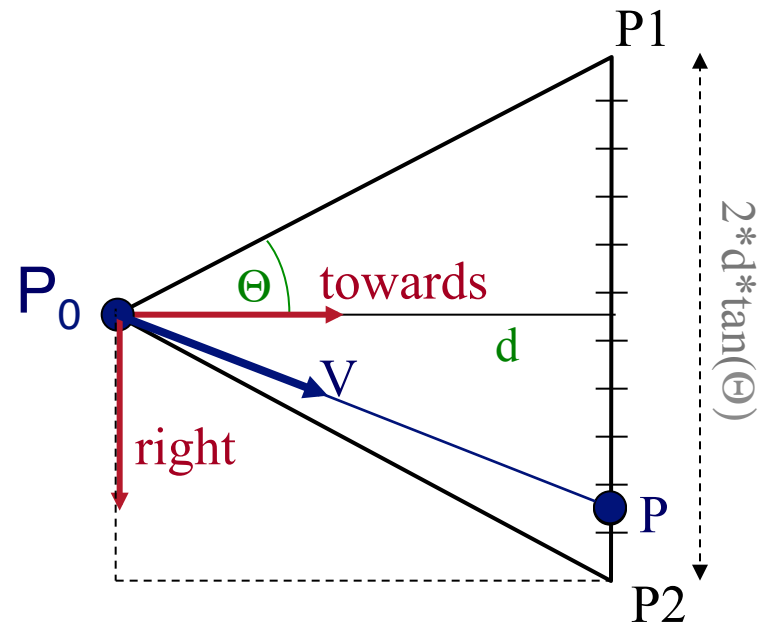

$$\text{Ray: } P = P_0 + tV$$

# Ray Casting



- Simple implementation:

```
R2Image *RayCast(R3Scene *scene, int width, int height)
{
    R2Image *image = new R2Image(width, height);
    for (int i = 0; i < width; i++) {
        for (int j = 0; j < height; j++) {
            R3Ray ray = ConstructRayThroughPixel(scene->camera, i, j);
            R3Rgb radiance = ComputeRadiance(scene, &ray);
            image->SetPixel(i, j, radiance);
        }
    }
    return image;
}
```



# Ray Casting

- Simple implementation:

```
R3Rgb ComputeRadiance(R3Scene *scene, R3Ray *ray)
{
    R3Intersection intersection = ComputeIntersection(scene, ray);
    return ComputeRadiance(scene, ray, intersection);
}
```

```
struct R3Intersection {
    bool hit;
    R3Node *node;
    R3Point position;
    R3Vector normal;
    double t;
};
```

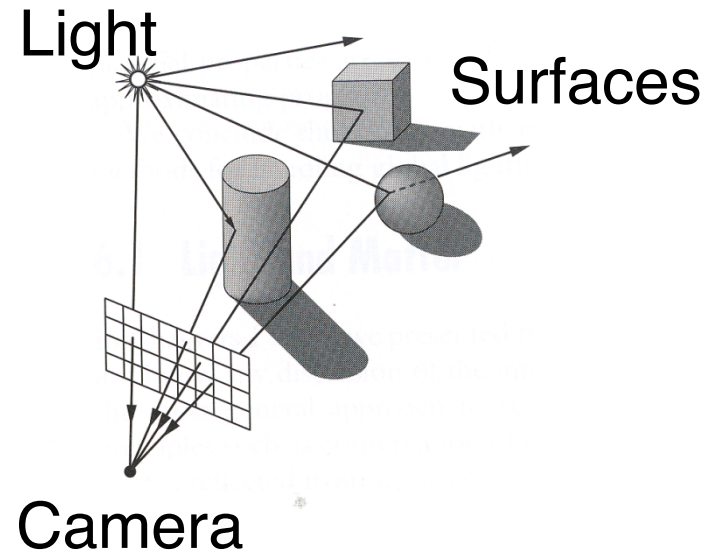

# Ray Casting

- Simple implementation:

```
R3Rgb ComputeRadiance(R3Scene *scene, R3Ray *ray)
{
    R3Intersection intersection = ComputeIntersection(scene, ray);
    return ComputeRadiance(scene, ray, intersection);
}
```

```
struct R3Intersection {
    bool hit;
    R3Node *node;
    R3Point position;
    R3Vector normal;
    double t;
};
```

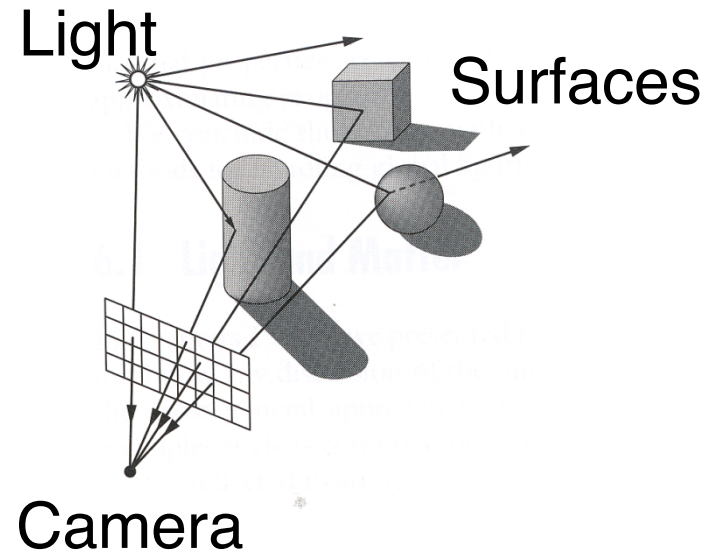



# Ray Intersection

- Ray Intersection
  - Sphere
  - Triangle
  - Box
  - Scene
  
- Ray Intersection Acceleration
  - Bounding volumes
  - Uniform grids
  - Octrees
  - BSP trees



# Ray Intersection

- Ray Intersection
  - Sphere
  - Triangle
  - Box
  - Scene
- Ray Intersection Acceleration
  - Bounding volumes
  - Uniform grids
  - Octrees
  - BSP trees

# Ray-Sphere Intersection

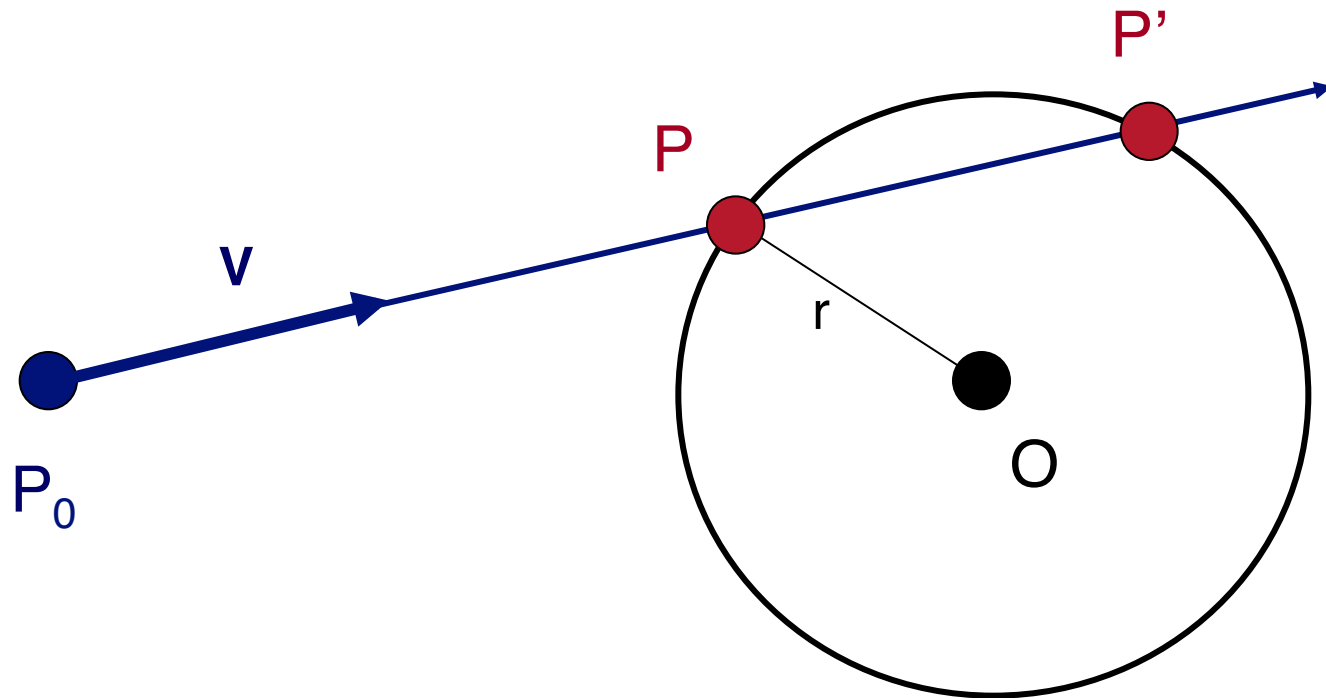





# Ray-Sphere Intersection

Ray:  $P = P_0 + tV$

Sphere:  $|P - O|^2 - r^2 = 0$

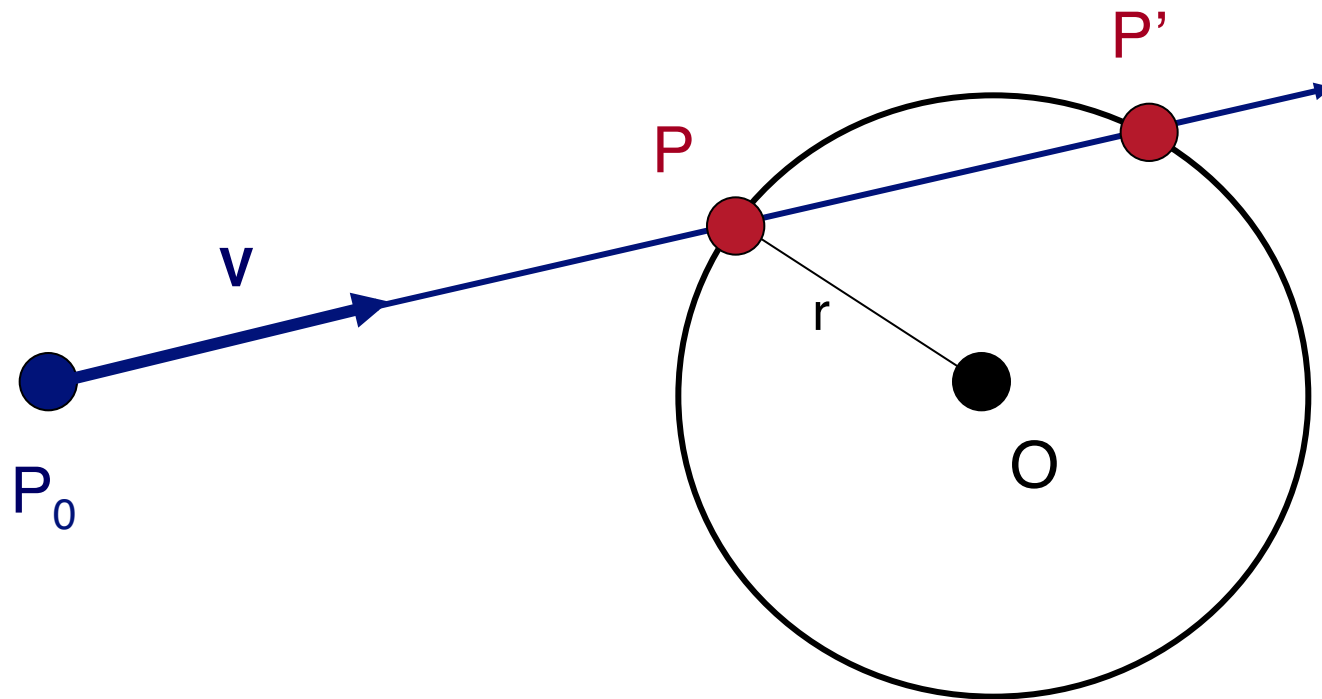



# Ray-Sphere Intersection I

Ray:  $P = P_0 + tV$

Sphere:  $|P - O|^2 - r^2 = 0$

Algebraic Method

Substituting for  $P$ , we get:

$$|P_0 + tV - O|^2 - r^2 = 0$$

Solve quadratic equation:

$$at^2 + bt + c = 0$$

where:

$$a = 1$$

$$b = 2V \cdot (P_0 - O)$$

$$c = |P_0 - O|^2 - r^2 = 0$$

$$P = P_0 + tV$$

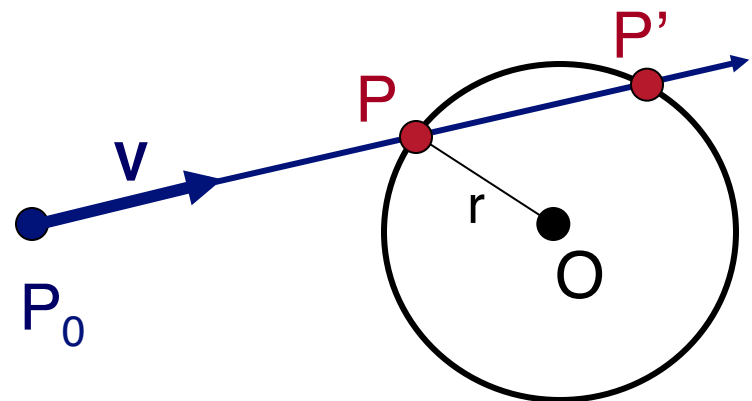



# Ray-Sphere Intersection II

$$\text{Ray: } P = P_0 + tV$$

$$\text{Sphere: } |P - O|^2 - r^2 = 0$$

Geometric Method

$$L = O - P_0$$

$$t_{ca} = L \cdot V$$

if ( $t_{ca} < 0$ ) return 0

$$d^2 = L \cdot L - t_{ca}^2$$

if ( $d^2 > r^2$ ) return 0

$$t_{hc} = \text{sqrt}(r^2 - d^2)$$

$$t = t_{ca} - t_{hc} \text{ and } t_{ca} + t_{hc}$$

$$P = P_0 + tV$$

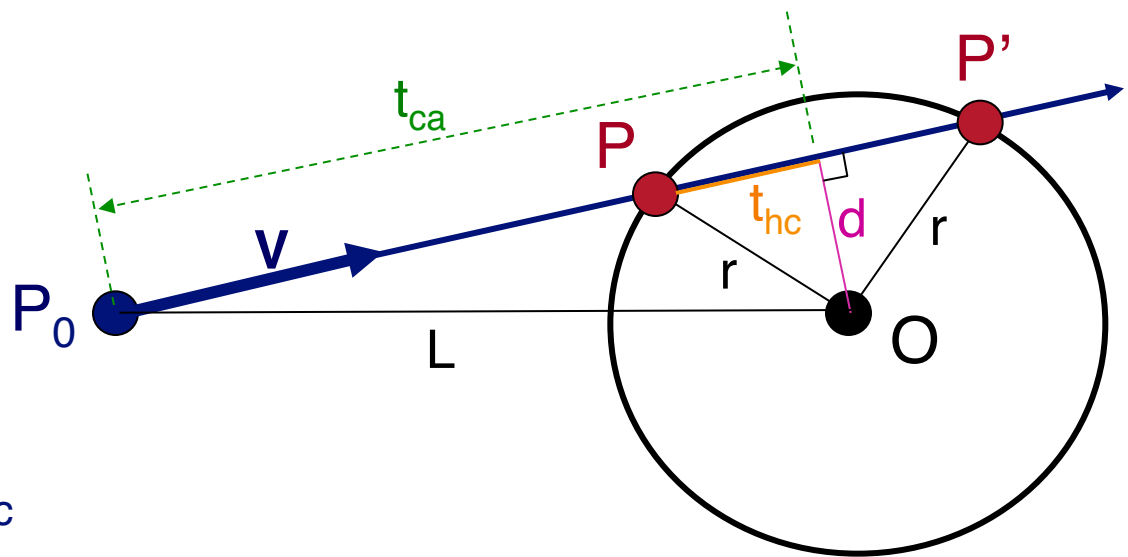

# Ray-Sphere Intersection

- Need normal vector at intersection for lighting calculations

$$N = (P - O) / \|P - O\|$$

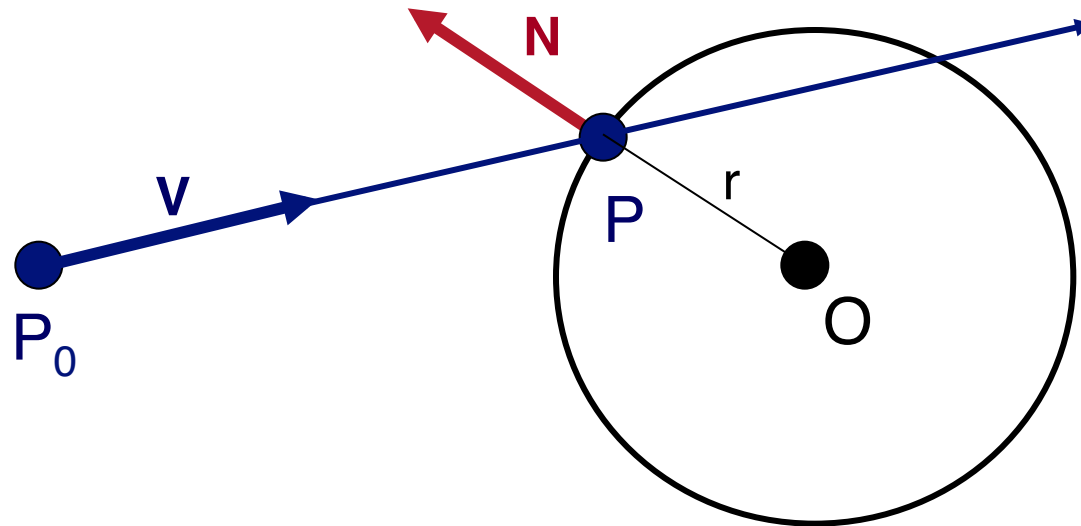



# Ray Intersection

- Ray Intersection
  - Sphere
  - Triangle
  - Box
  - Scene
  
- Ray Intersection Acceleration
  - Bounding volumes
  - Uniform grids
  - Octrees
  - BSP trees

# Ray-Triangle Intersection

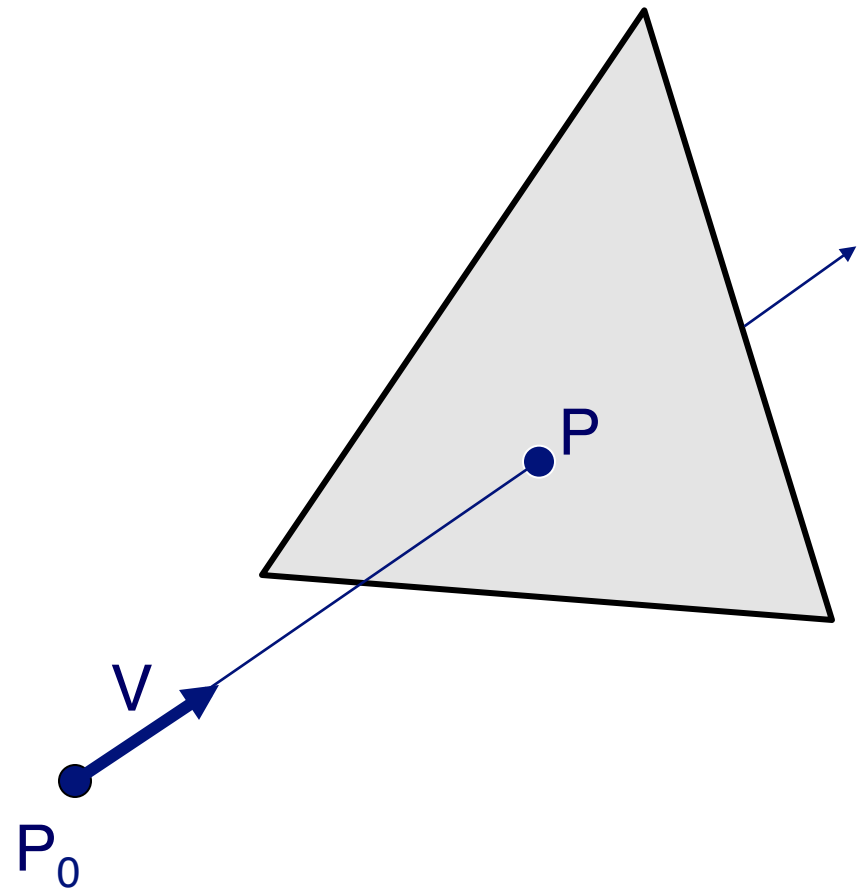



# Ray-Triangle Intersection

- First, intersect ray with plane
- Then, check if intersection point is inside triangle

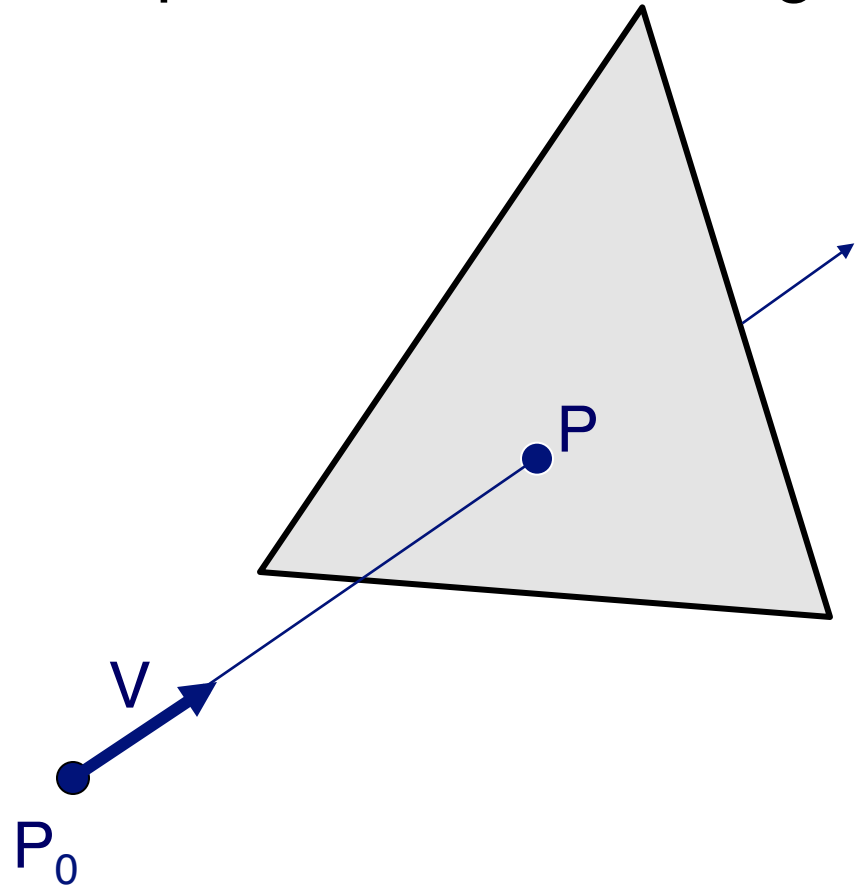



# Ray-Plane Intersection

$$\text{Ray: } P = P_0 + tV$$

$$\text{Plane: } P \cdot N + d = 0$$

Algebraic Method

Substituting for  $P$ , we get:

$$(P_0 + tV) \cdot N + d = 0$$

Solution:

$$t = -(P_0 \cdot N + d) / (V \cdot N)$$

$$P = P_0 + tV$$

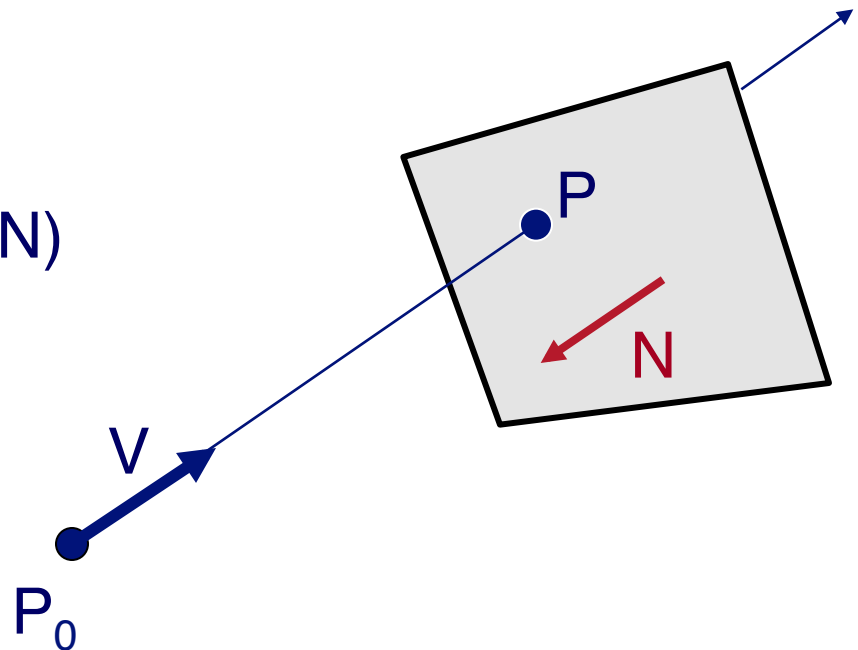





# Ray-Triangle Intersection I

- Check if point is inside triangle algebraically

For each side of triangle

$$V_1 = T_1 - P_0$$

$$V_2 = T_2 - P_0$$

$$N_1 = V_2 \times V_1$$

Normalize  $N_1$

Plane  $p(P_0, N_1)$

if (SignedDistance( $p$ ,  $P$ ) < 0)

return FALSE

end

return TRUE

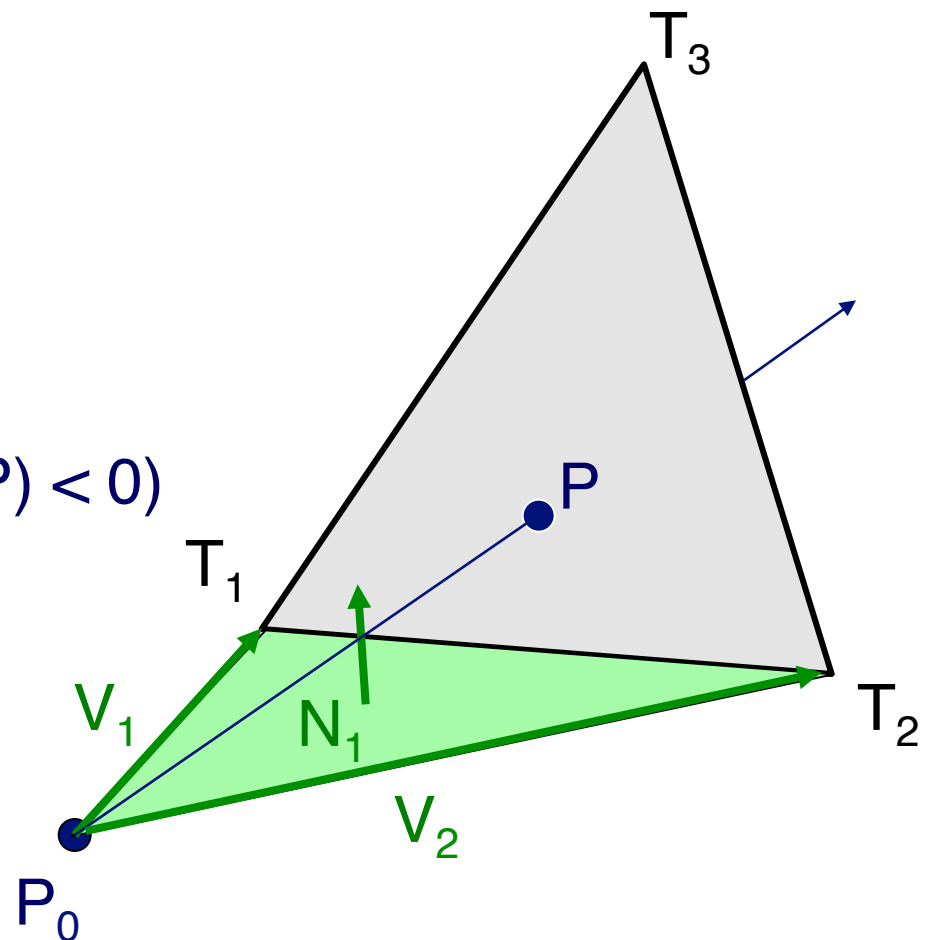



# Ray-Triangle Intersection II

- Check if point is inside triangle algebraically

For each side of triangle

$$V_1 = T_1 - P$$

$$V_2 = T_2 - P$$

$$N_1 = V_2 \times V_1$$

$$\text{if } (V \cdot N_1 < 0)$$

return FALSE

end

return TRUE

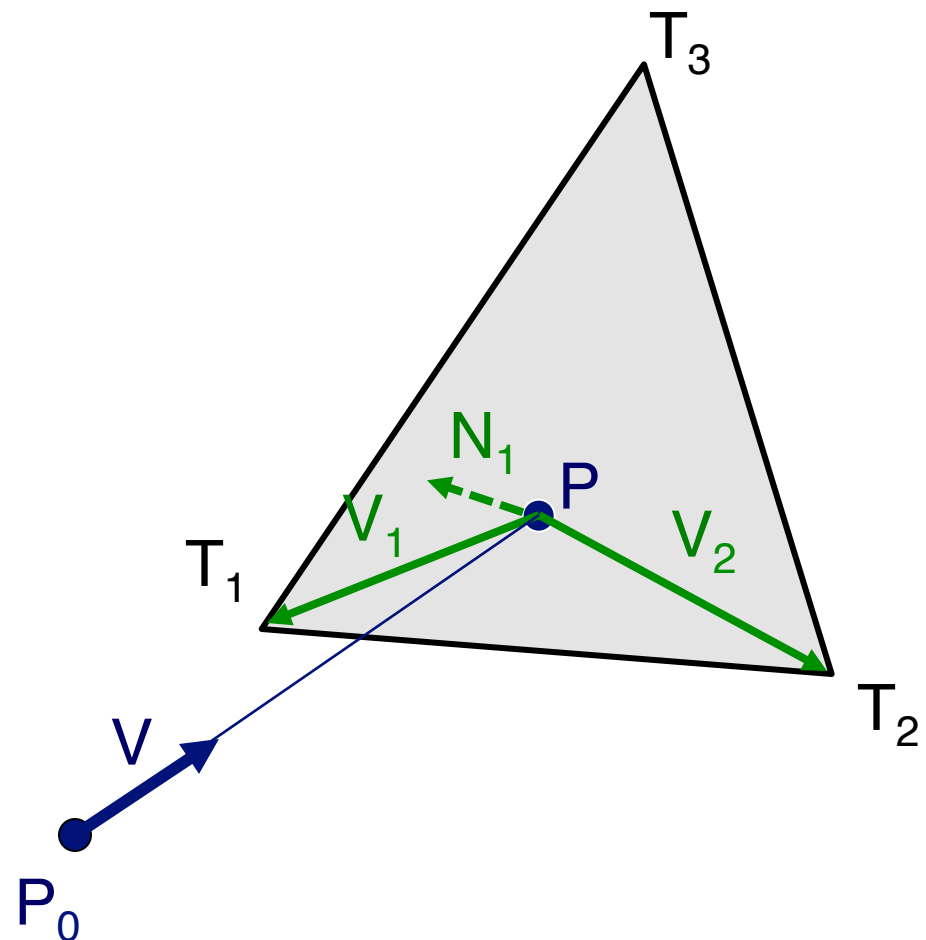



# Ray-Triangle Intersection II

- Check if point is inside triangle algebraically

For each side of triangle

$$V_1 = T_1 - P$$

$$V_2 = T_2 - P$$

$$N_1 = V_2 \times V_1$$

$$\text{if } (V \cdot N_1 < 0)$$

return FALSE

end

return TRUE

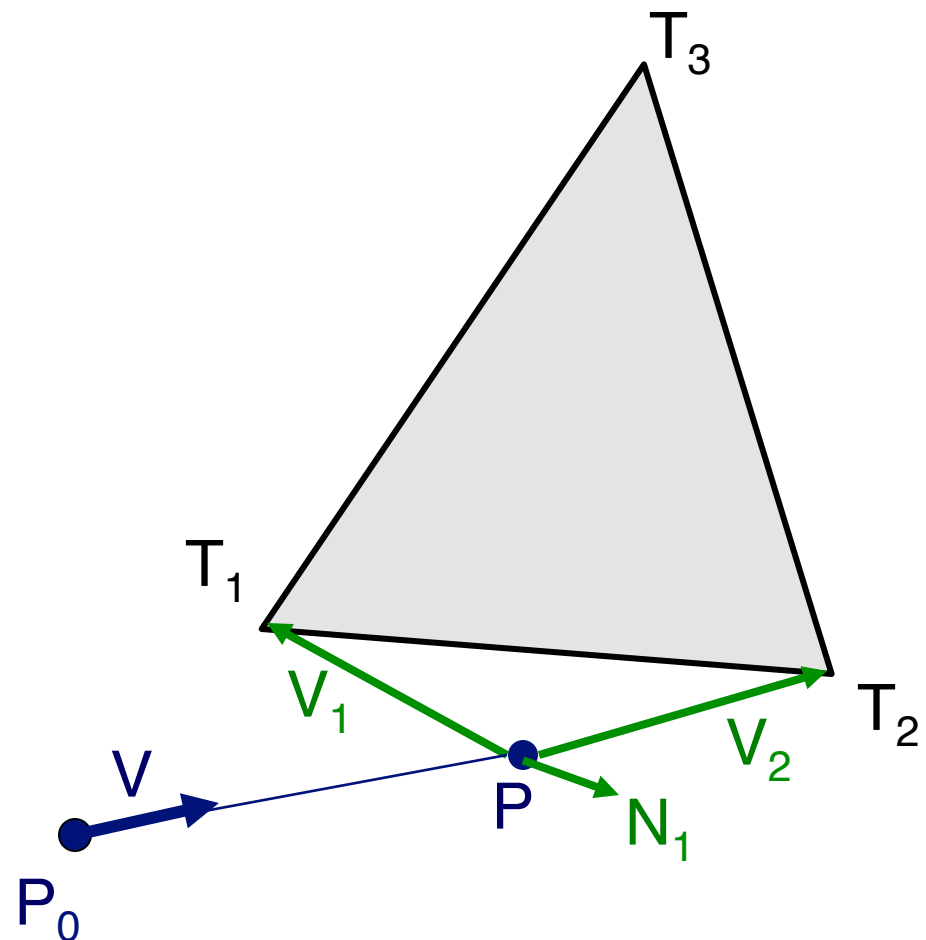



# Ray-Triangle Intersection III

- Check if point is inside triangle parametrically

“Barycentric coordinates”  $\alpha, \beta, \gamma$ :

$$P = \alpha T_3 + \beta T_2 + \gamma T_1$$

where  $\alpha + \beta + \gamma = 1$

$$\alpha = \text{Area}(T_1 T_2 P) / \text{Area}(T_1 T_2 T_3)$$

$$\beta = \text{Area}(T_1 P T_3) / \text{Area}(T_1 T_2 T_3)$$

$$\gamma = \text{Area}(P T_2 T_3) / \text{Area}(T_1 T_2 T_3)$$

$$= 1 - \alpha - \beta$$

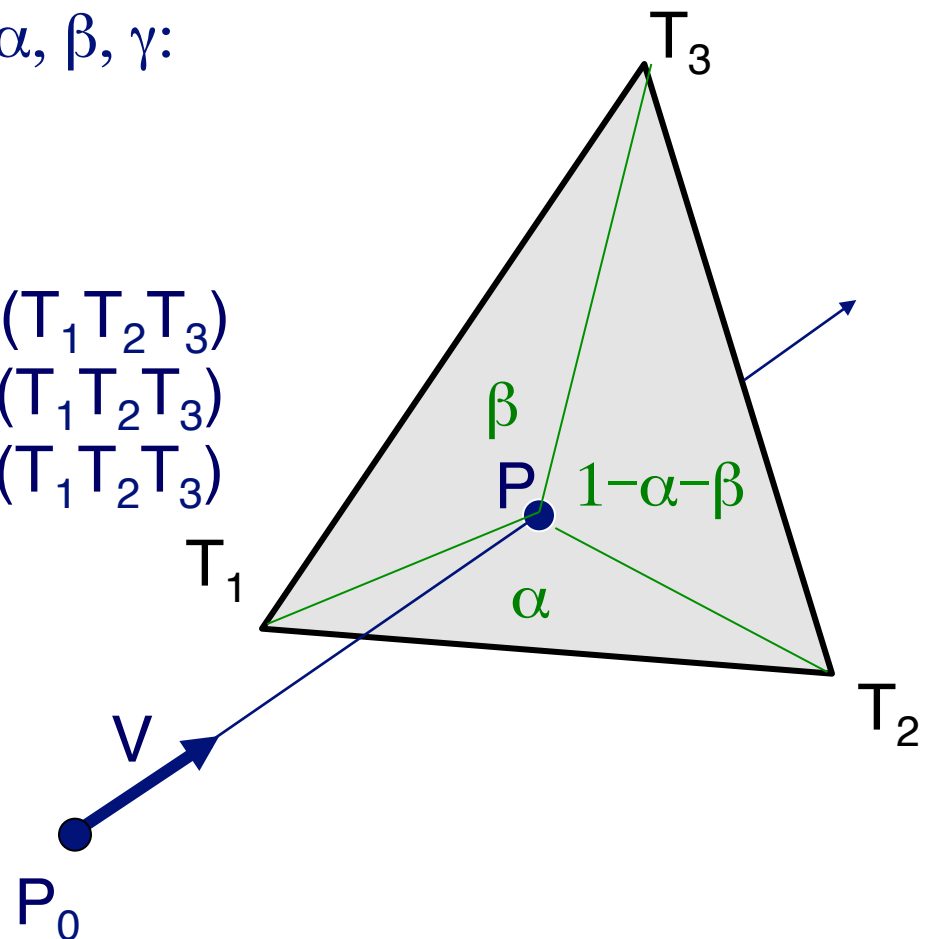



# Ray-Triangle Intersection III

- Check if point is inside triangle parametrically

Compute “barycentric coordinates”  $\alpha$ ,  $\beta$ :

$$\alpha = \text{Area}(T_1T_2P) / \text{Area}(T_1T_2T_3)$$

$$\beta = \text{Area}(T_1PT_3) / \text{Area}(T_1T_2T_3)$$

$$\text{Area}(T_1T_2T_3) = \frac{1}{2} \| (T_2 - T_1) \times (T_3 - T_1) \|$$

check if backfacing:

$$((T_2 - T_1) \times (T_3 - T_1)) \cdot N < 0$$

Check if point inside triangle.

$$0 \leq \alpha \leq 1 \text{ and } 0 \leq \beta \leq 1$$

$$\text{and } \alpha + \beta \leq 1$$

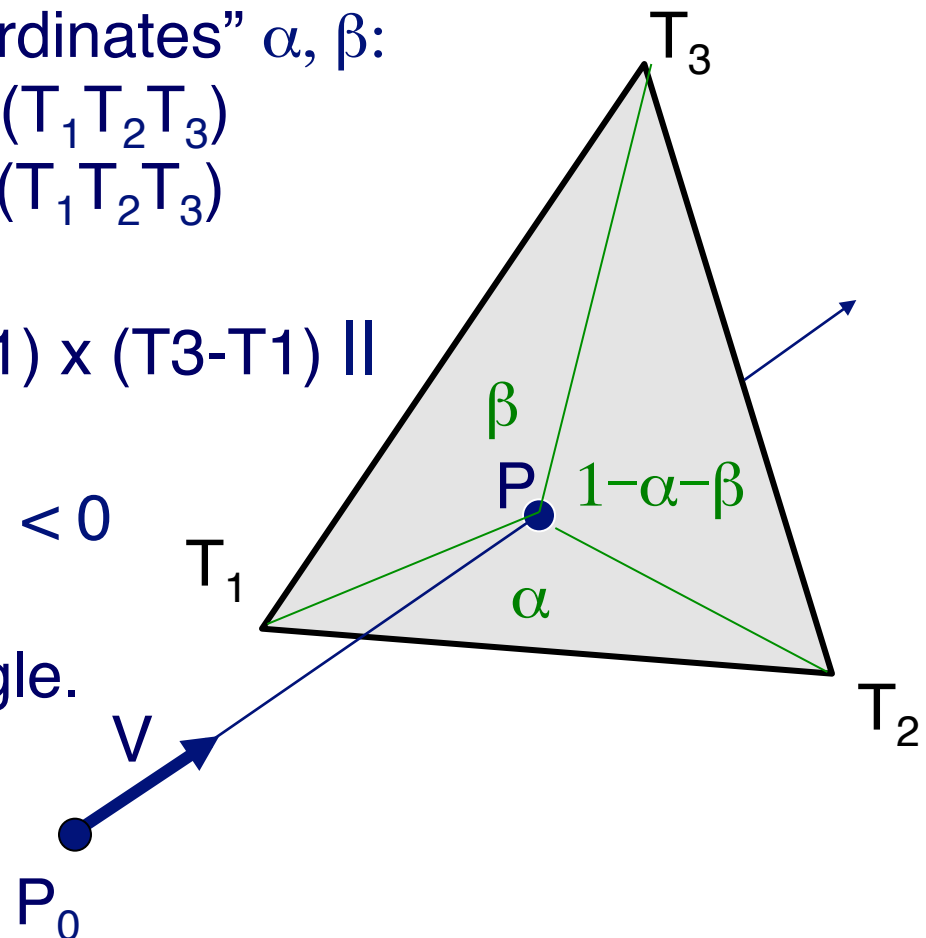



# Ray Intersection

- Ray Intersection
  - Sphere
  - Triangle
  - **Box**
  - Scene
  
- Ray Intersection Acceleration
  - Bounding volumes
  - Uniform grids
  - Octrees
  - BSP trees



# Ray-Box Intersection

- Check front-facing sides for intersection with ray and return closest intersection (least  $t$ )

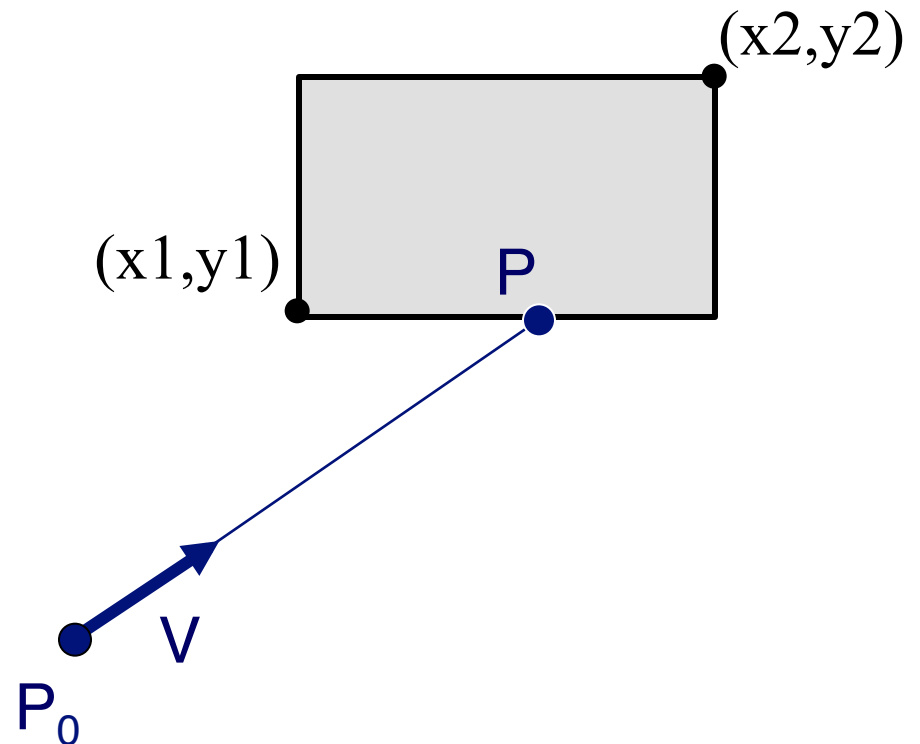



# Ray-Box Intersection

- Check front-facing sides for intersection with ray and return closest intersection (least  $t$ )
  - Find intersection with plane
  - Check if point is inside rectangle

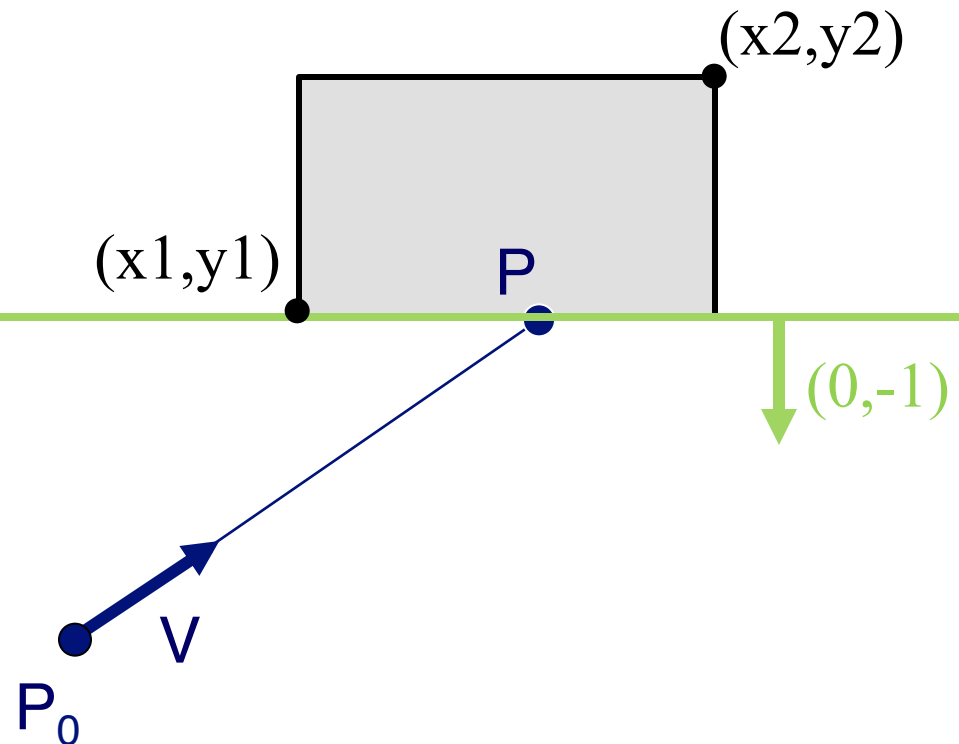





# Ray-Box Intersection

- **Check** front-facing sides for intersection with ray and return closest intersection (least  $t$ )
  - Find intersection with plane
  - Check if point is inside rectangle

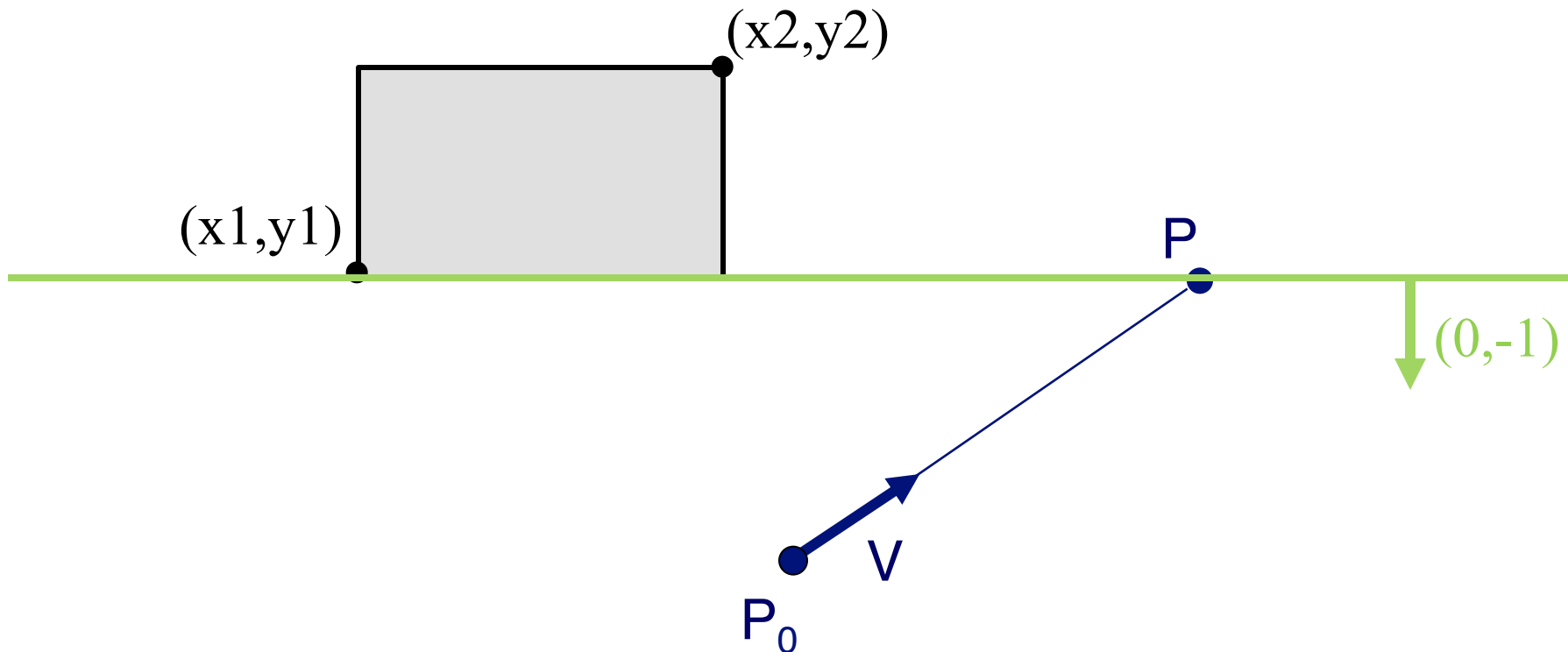

# Other Ray-Primitive Intersections



- Cone, cylinder:
  - Similar to sphere
  - Must also check end caps
- Convex polygon
  - Same as triangle (check point-in-polygon algebraically)
  - Or, decompose into triangles, and check all of them
- Mesh
  - Compute intersection for all polygons
  - Return closest intersection (least  $t$ )

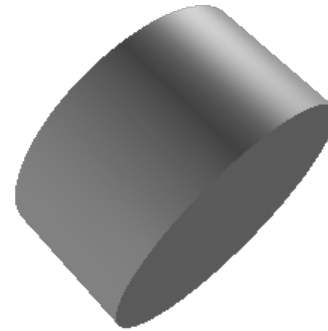



# Ray Intersection

- Ray Intersection
  - Sphere
  - Triangle
  - Box
  - Scene
  
- Ray Intersection Acceleration
  - Bounding volumes
  - Uniform grids
  - Octrees
  - BSP trees

# Ray-Scene Intersection

- Intuitive method
  - Compute intersection for all nodes of scene graph
  - Return closest intersection (least  $t$ )

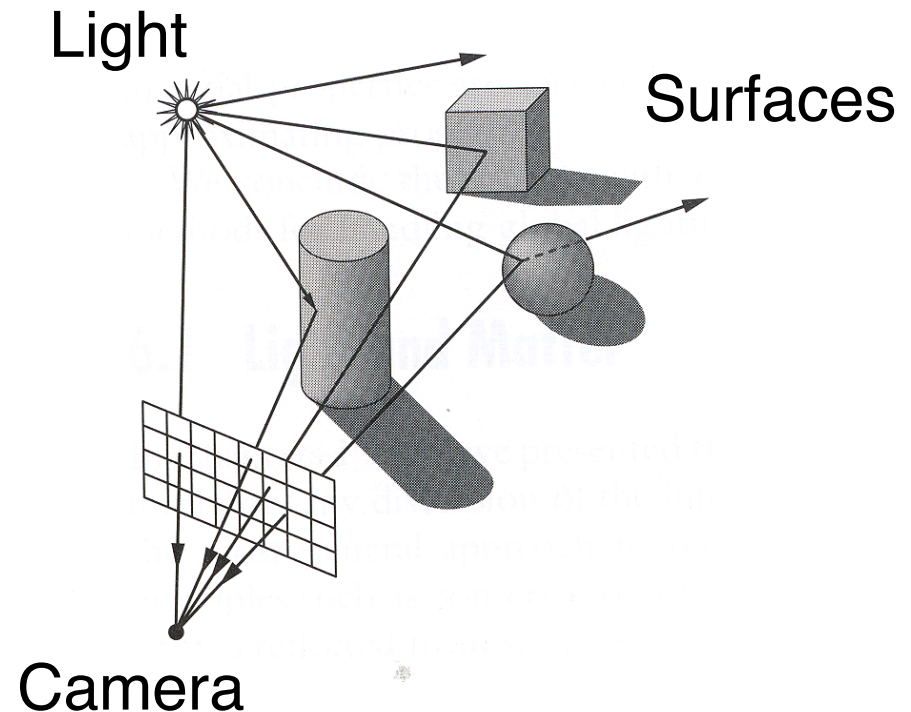

# Ray-Scene Intersection

- Scene graph is a DAG
  - Traverse with recursion

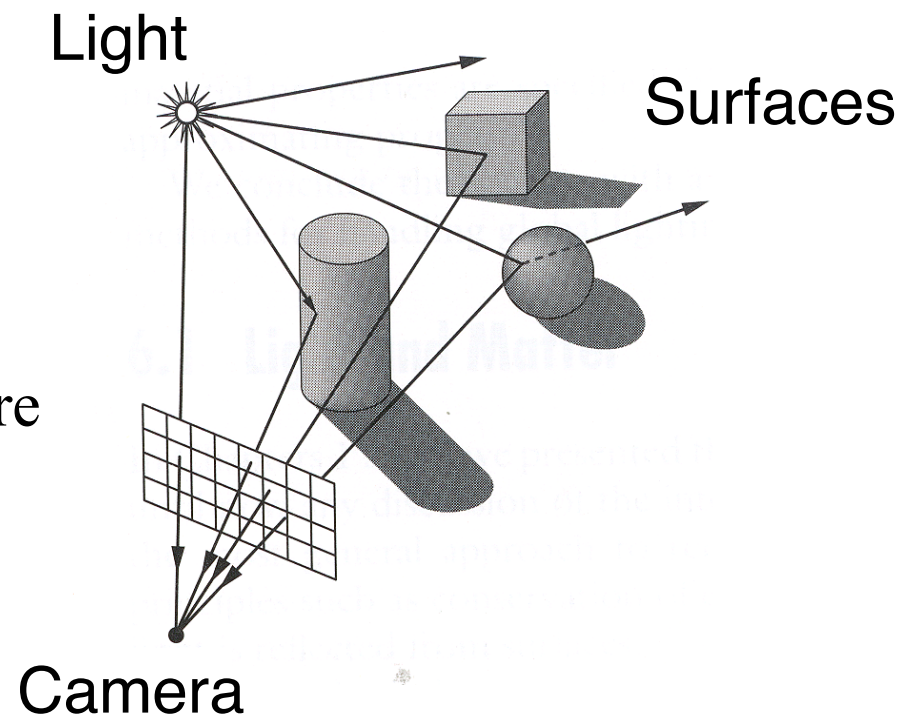
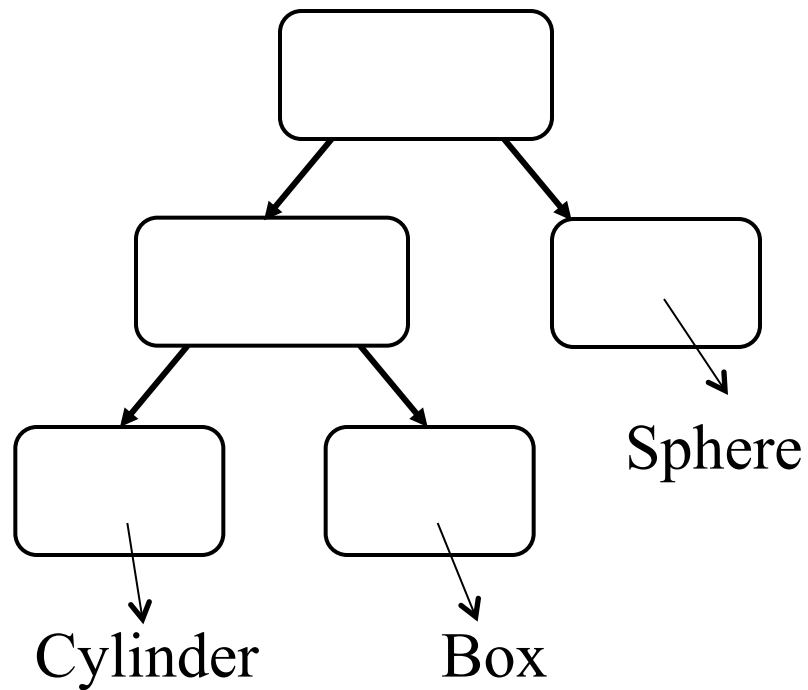

# Ray-Scene Intersection I



```
R3Intersection ComputeIntersection(R3Scene *scene, R3Node *node, R3Ray *ray)
{
    // Check for intersection with shape
    shape_intersection = Intersect node's shape with ray
    if (shape_intersection is a hit) closest_intersection = shape_intersection
    else closest_intersection = infinitely far miss

    // Check for intersection with children nodes
    for each child node
        // Check for intersection with child contents
        child_intersection = ComputeIntersection(scene, child, ray);
        if (child_intersection is a hit and is closer than closest_intersection)
            closest_intersection = child_intersection;

    // Return closest intersection in tree rooted at this node
    return closest_intersection
}
```

# Ray-Scene Intersection

- Scene graph can have transformations

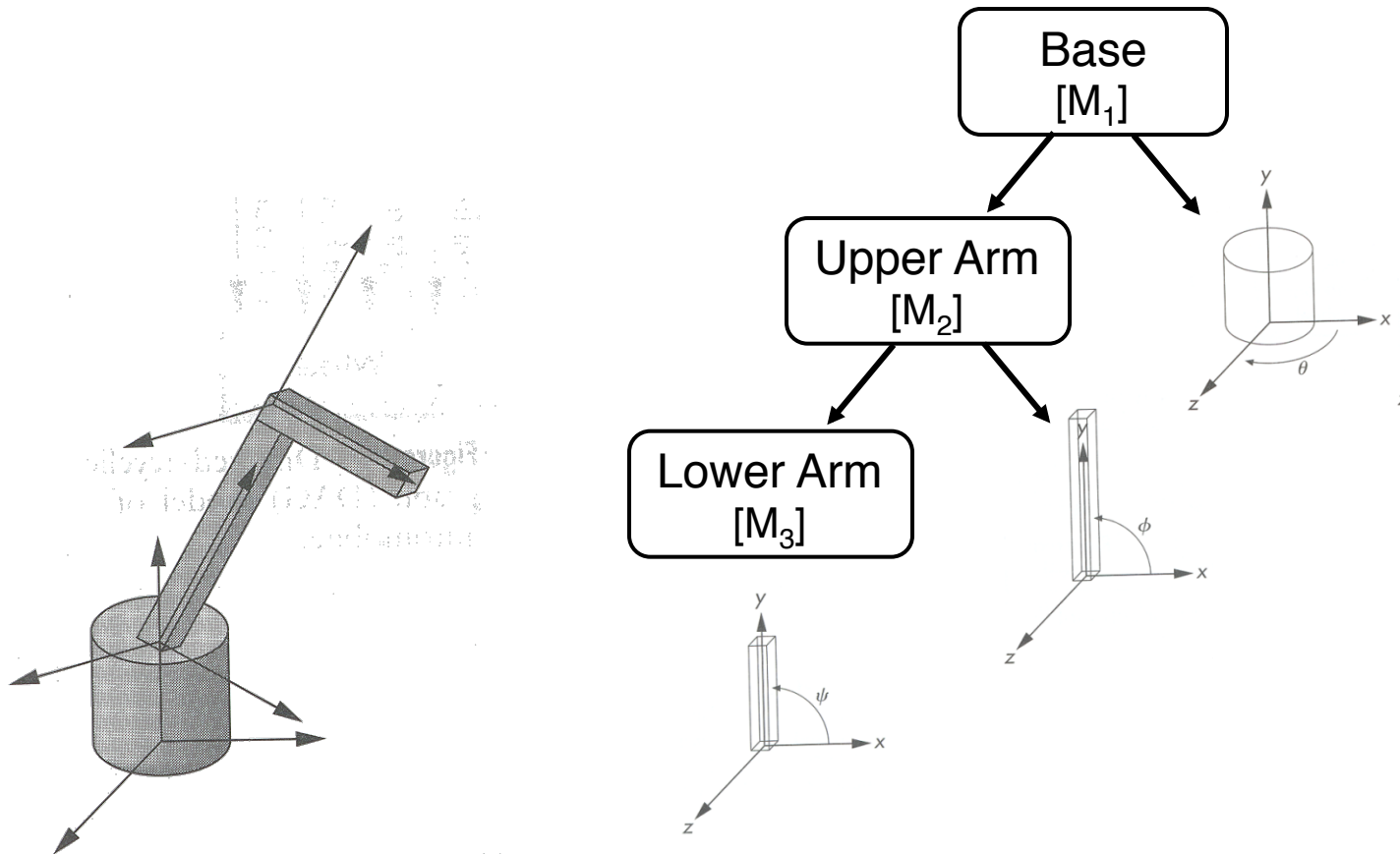

# Ray-Scene Intersection

- Scene graph node can have transformations
  - Transform **ray** (not primitives) by **inverse** of  $M$
  - Intersect in coordinate system of node
  - Transform intersection by  $M$

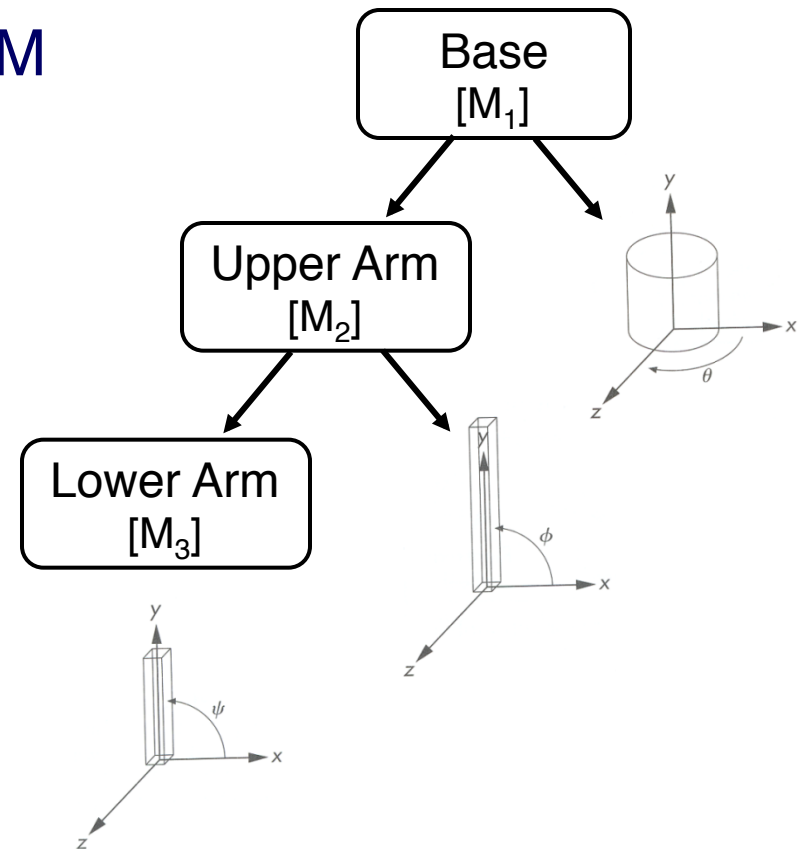
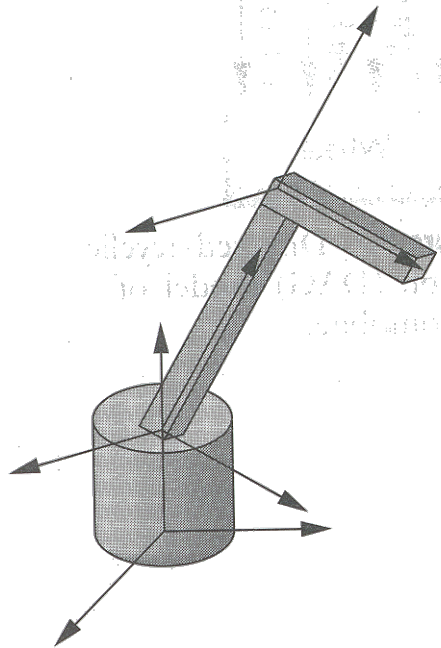



# Ray-Scene Intersection II



```
R3Intersection ComputeIntersection(R3Scene *scene, R3Node *node, R3Ray *ray)
{
    // Transform ray by inverse of node's transformation

    // Check for intersection with shape

    // Check for intersection with children nodes

    // Transform intersection by node's transformation

    // Return closest intersection in tree rooted at this node
}
```



# Ray-Scene Intersection II

```
R3Intersection ComputeIntersection(R3Scene *scene, R3Node *node, R3Ray *ray)
{
    // Transform ray by inverse of node's transformation

    // Check for intersection with shape

    // Check for intersection with children nodes

    // Transform intersection by node's transformation

    // Return closest intersection in tree rooted at this node
}
```

**Note:** directions (including ray direction and surface normal  $N$ ) must be transformed by inverse transpose of  $M$

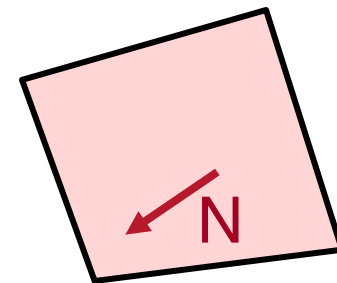



# Ray Intersection

- Ray Intersection
  - Sphere
  - Triangle
  - Box
  - Scene
  
- Ray Intersection Acceleration
  - Bounding volumes
  - Uniform grids
  - Octrees
  - BSP trees

# Ray Intersection Acceleration

- What if there are a lot of nodes?

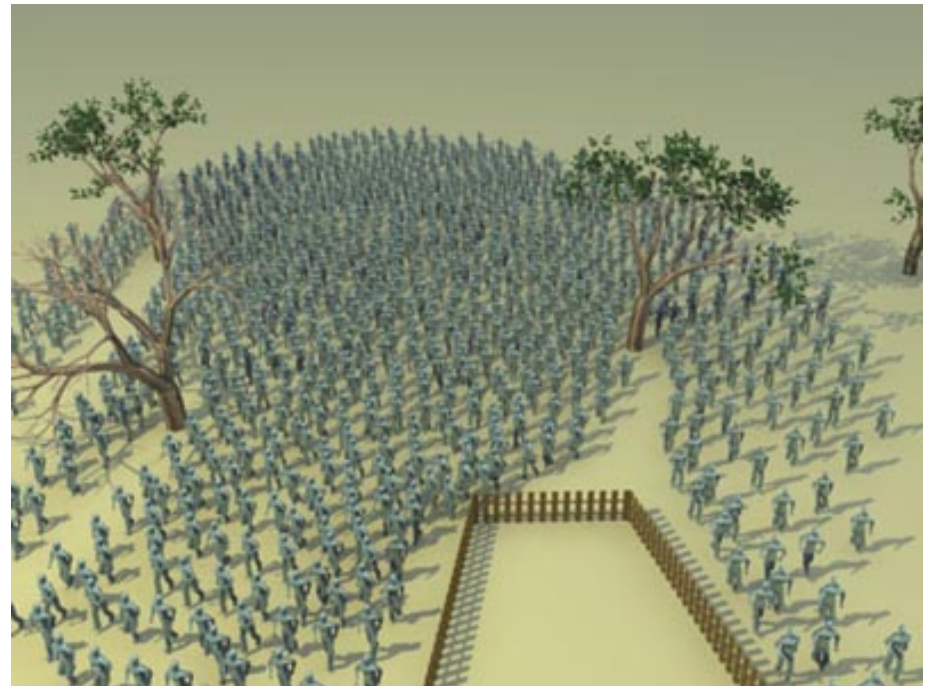
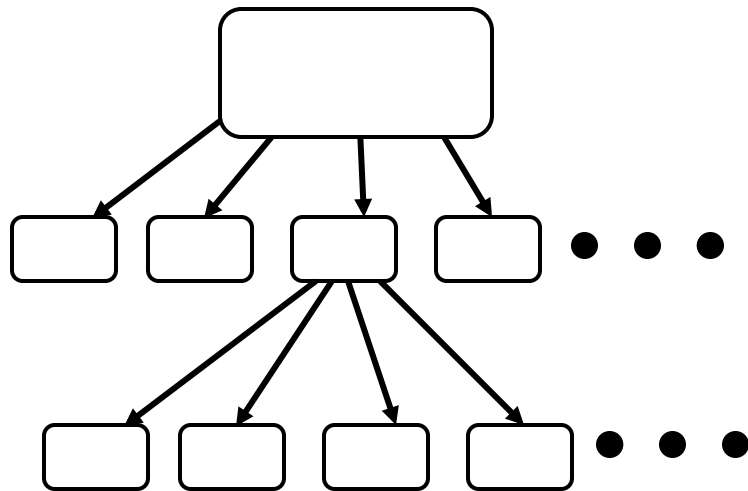

# Bounding Volumes

- Check for intersection with simple bounding volume first

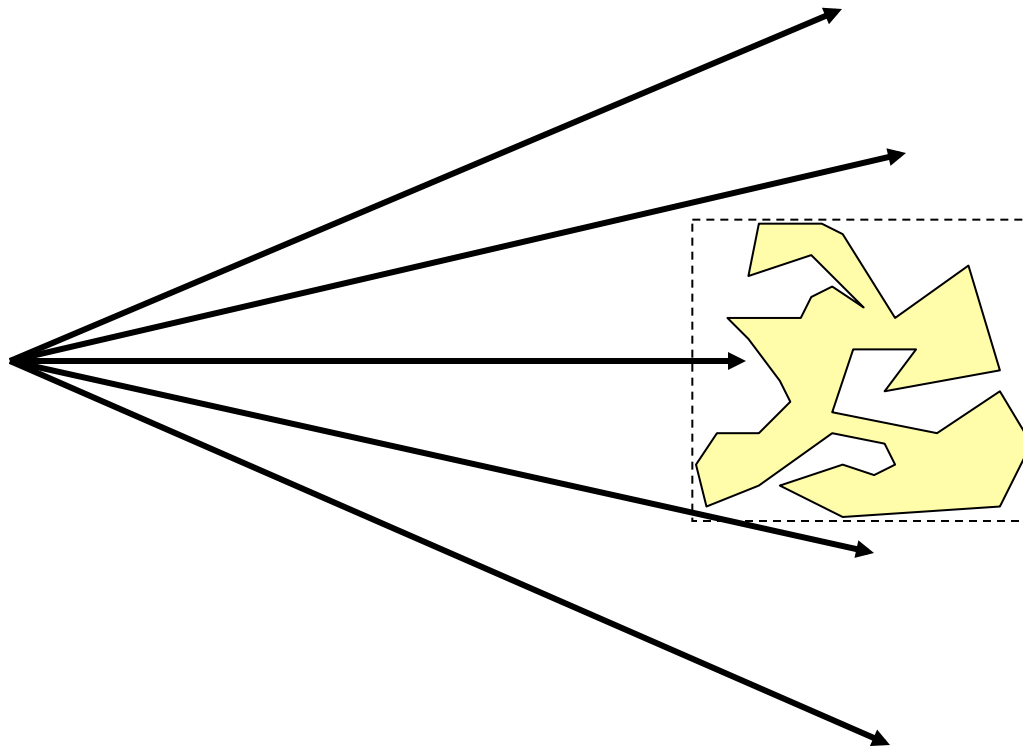

# Bounding Volumes



- Check for intersection with bounding volume first

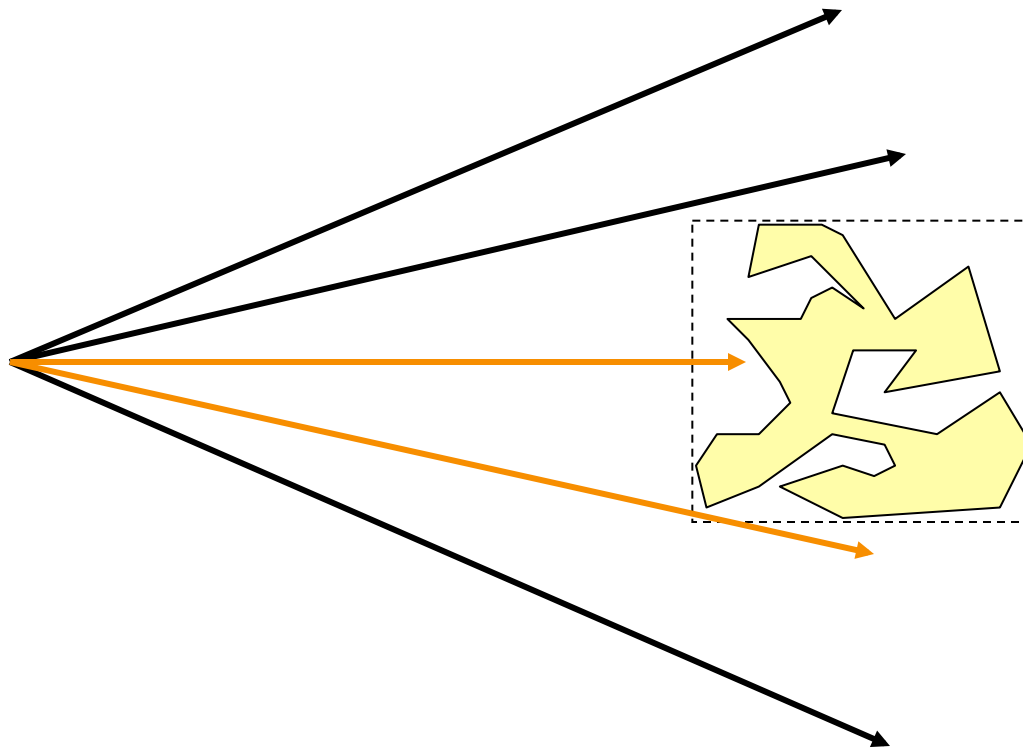

# Bounding Volumes

- Check for intersection with bounding volume first
  - If ray doesn't intersect bounding volume, then it can't intersect its contents

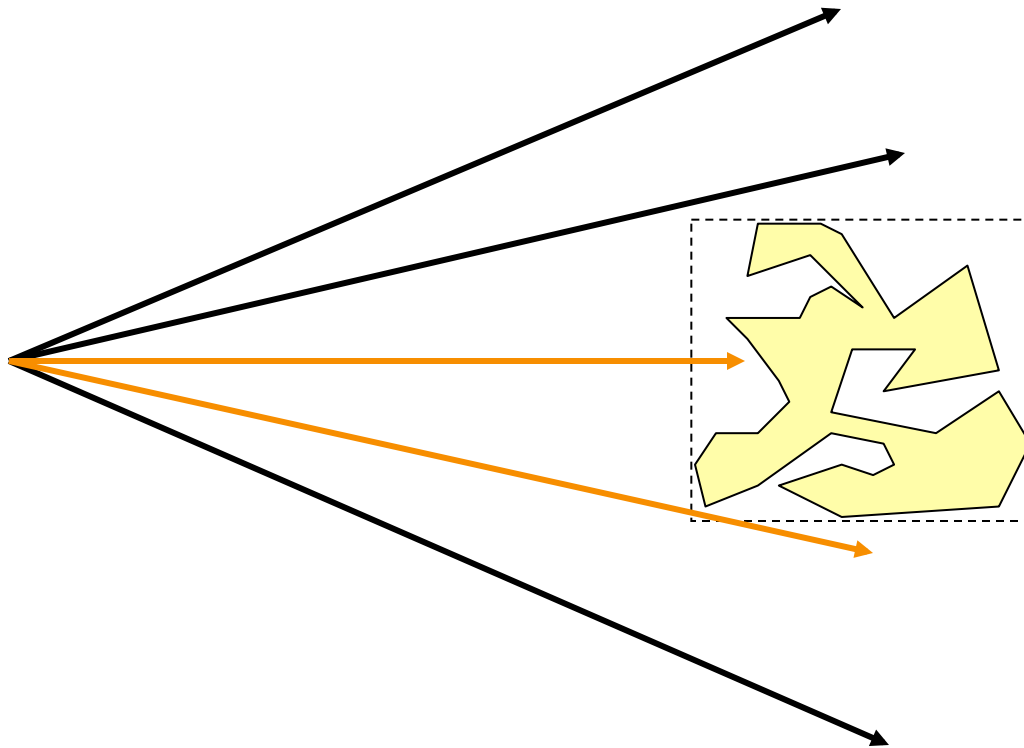

# Bounding Volumes

- Check for intersection with bounding volume first
  - If already found a primitive intersection closer than intersection with bounding box, then skip checking contents of bounding box

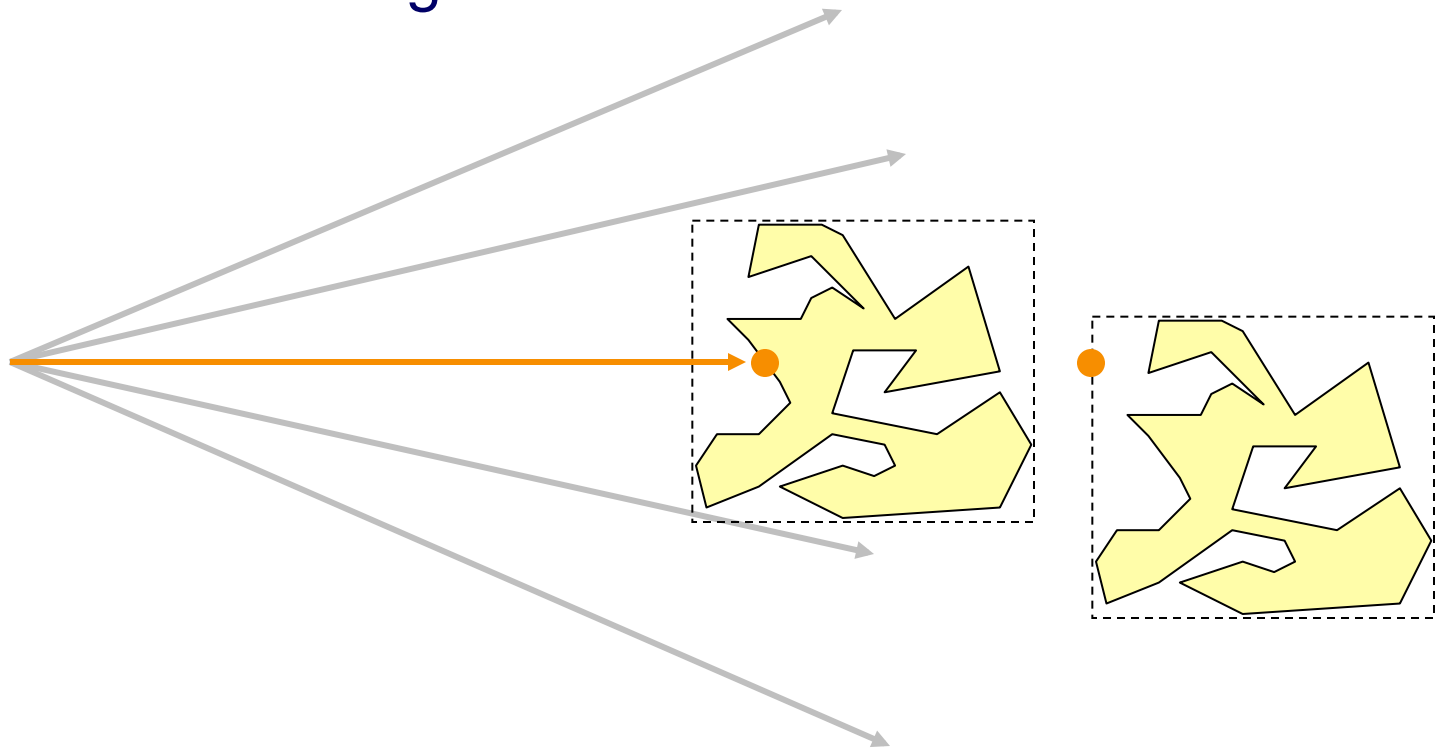





# Bounding Volume Hierarchies

- Scene graph has hierarchy of bounding volumes
  - Bounding volume of interior node contains all children

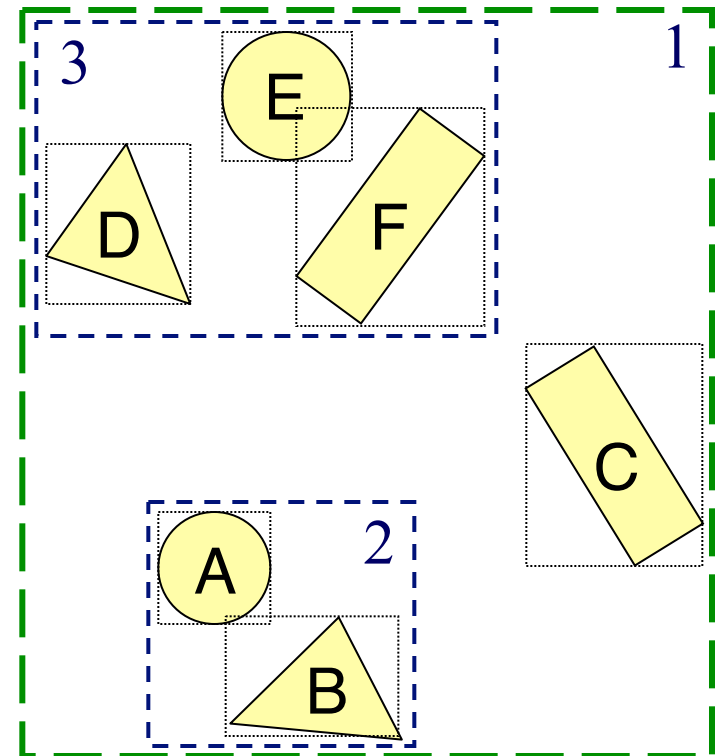
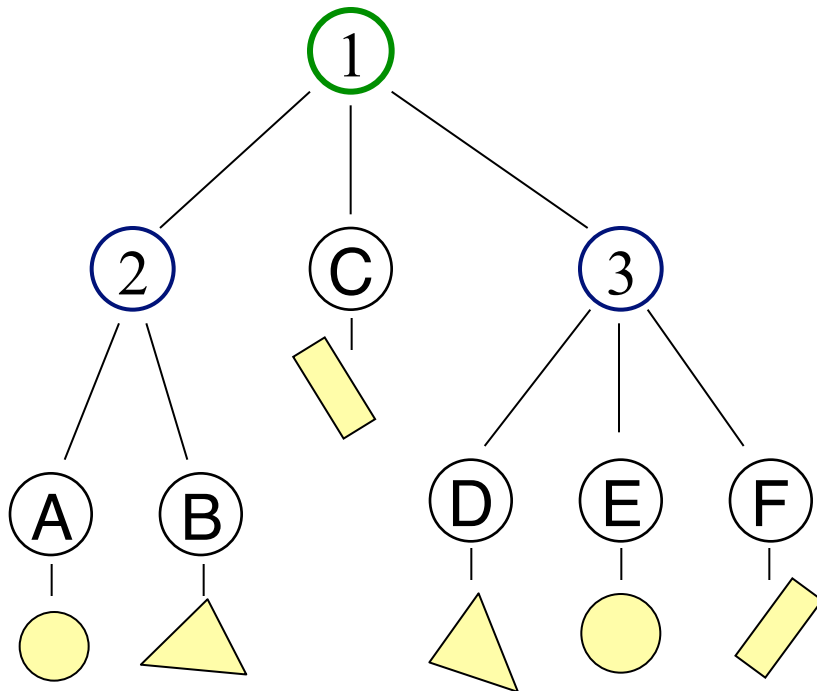



# Bounding Volume Hierarchies

- Checking bounding volumes hierarchically (within each node) can greatly accelerate ray intersection

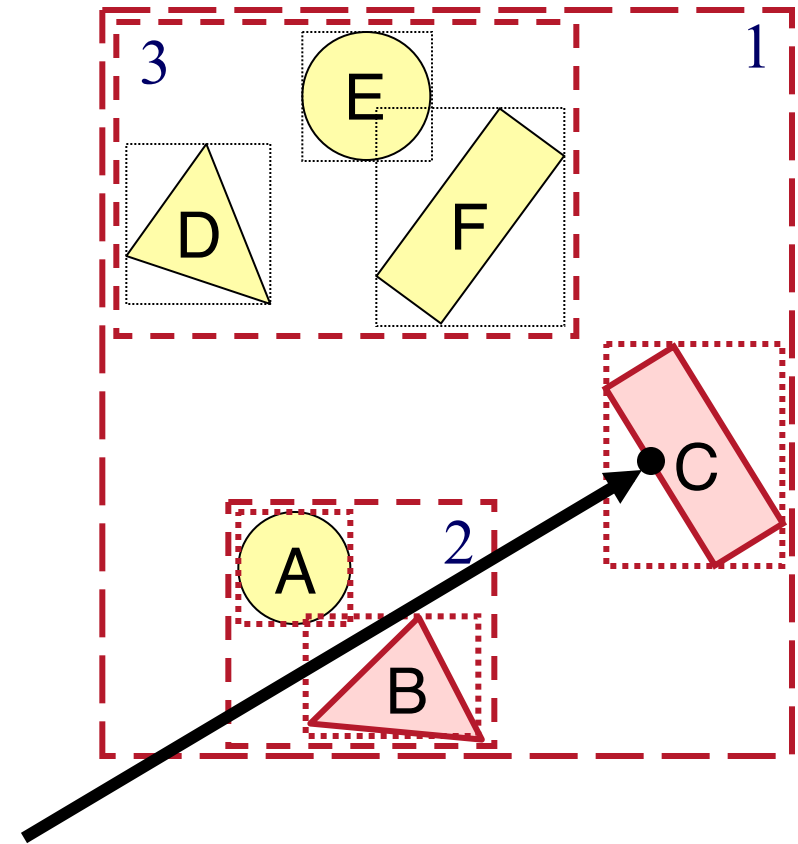
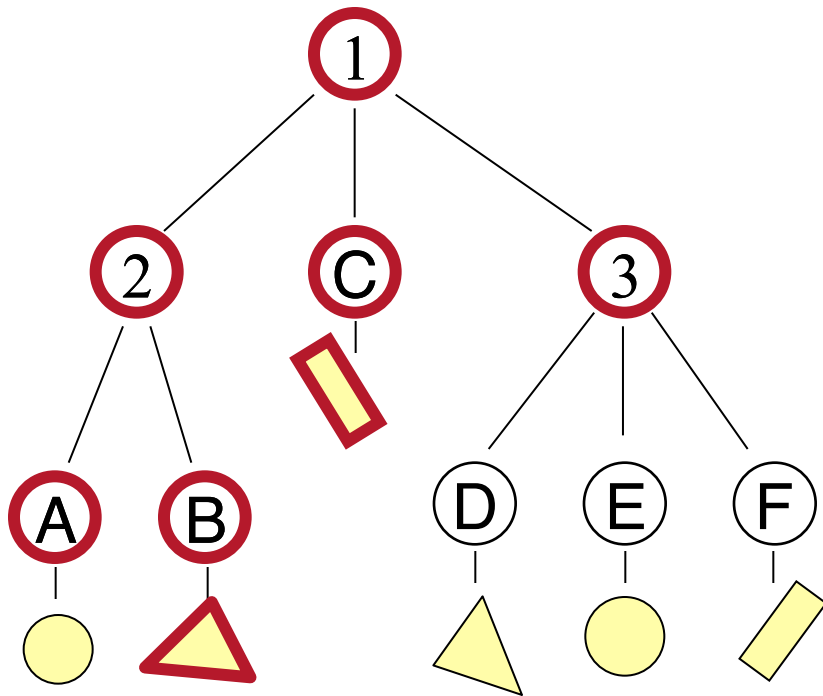

# Bounding Volume Hierarchies



```
R3Intersection ComputeIntersection(R3Scene *scene, R3Node *node, R3Ray *ray)
{
    // Transform ray by inverse of node's transformation
    // Check for intersection with shape

    // Check for intersection with children nodes
    for each child node
        // Check for intersection with child bounding box first
        bbox_intersection = Intersect child's bounding box with ray
        if (bbox_intersection is a miss or further than closest_intersection) continue

        // Check for intersection with child contents
        child_intersection = ComputeIntersection(scene, child, ray);
        if (child_intersection is a hit and is closer than closest_intersection)
            closest_intersection = child_intersection;

    // Transform intersection by node's transformation
    // Return closest intersection in tree rooted at this node
}
```

# Sort Bounding Volume Intersections



- Sort child bounding volume intersections and then visit child nodes in front-to-back order
- Why?

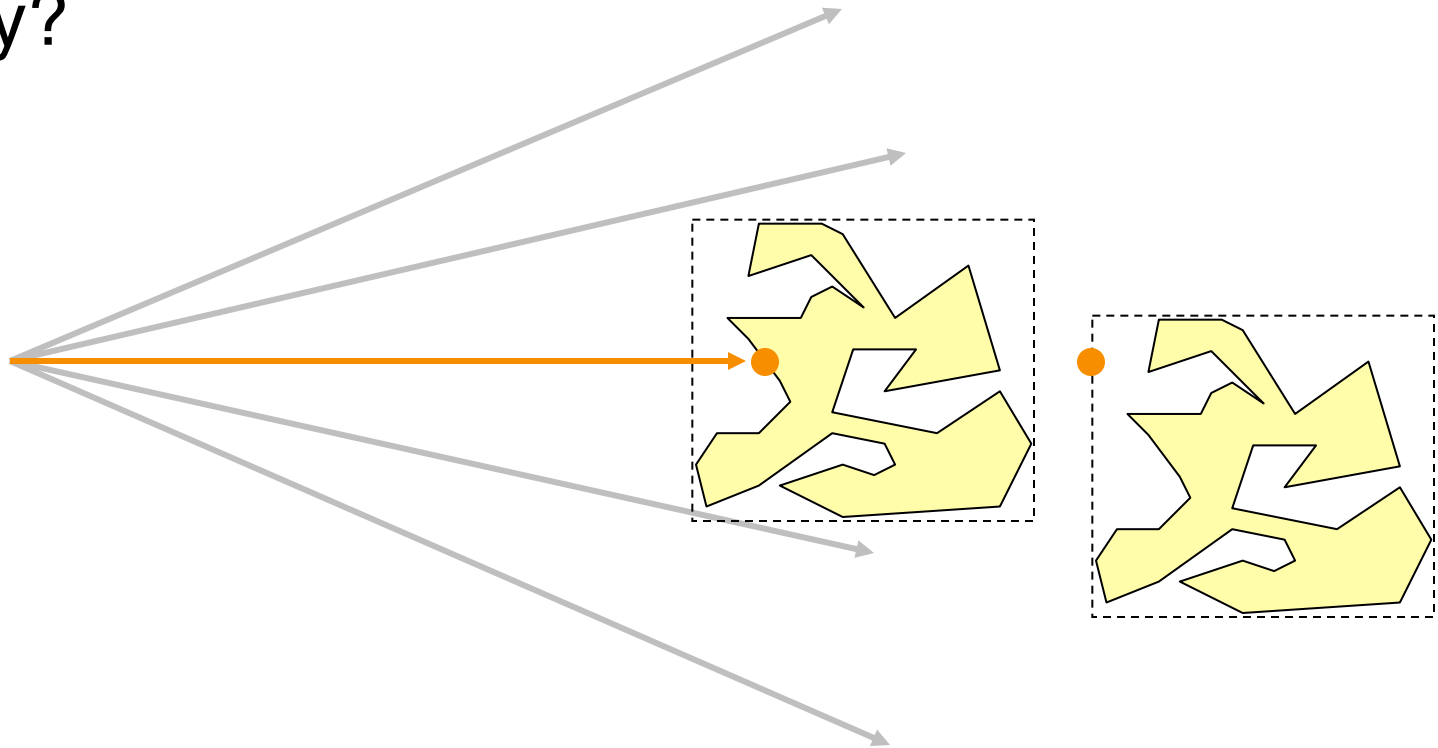



# Cache Node Intersections

- For each node, store closest child intersection from previous ray and check that node first

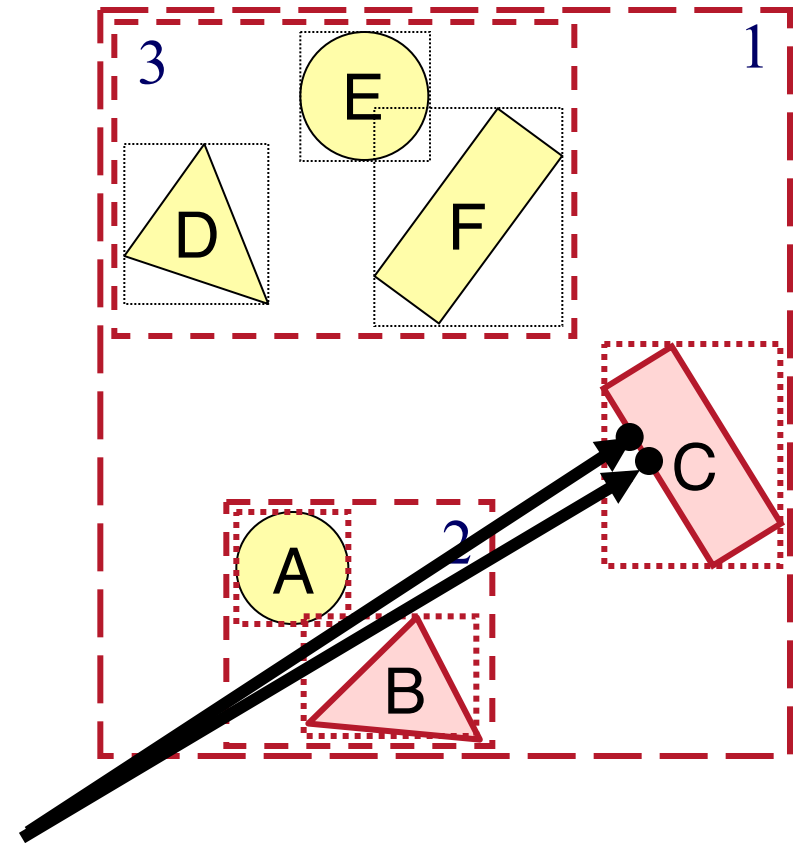
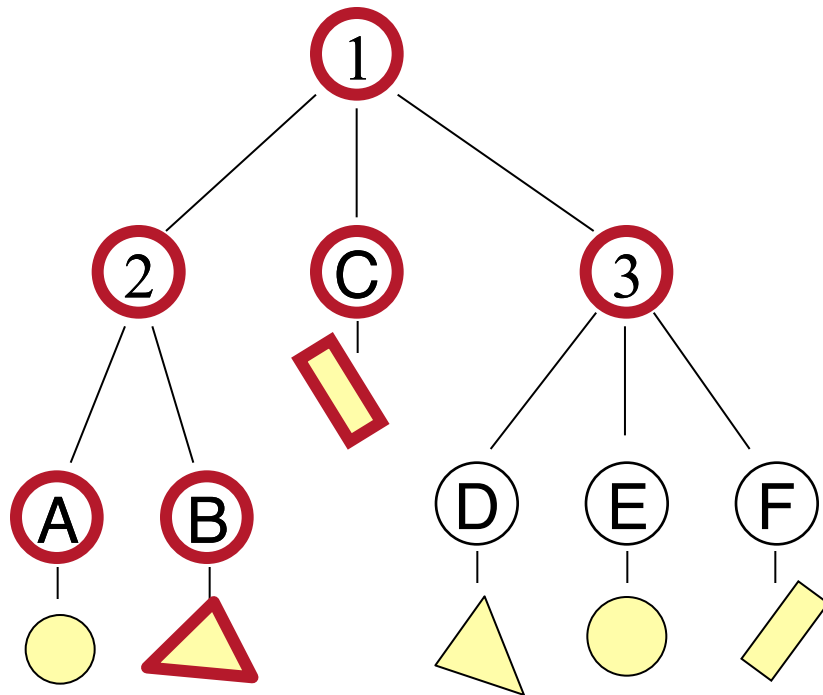



# Bounding Volumes

- Common primitives are:
  - Axis-aligned bounding box
  - Sphere
- What are the tradeoffs?
  - Sphere has simple/efficient intersection code
  - Bounding box is generally “tighter”



# Ray Intersection

- Ray Intersection
  - Sphere
  - Triangle
  - Box
  - Scene
  
- Ray Intersection Acceleration
  - Bounding volumes
  - **Uniform grids**
  - Octrees
  - BSP trees

# Uniform Grid

- Construct uniform grid over scene
  - Index primitives according to overlaps with grid cells

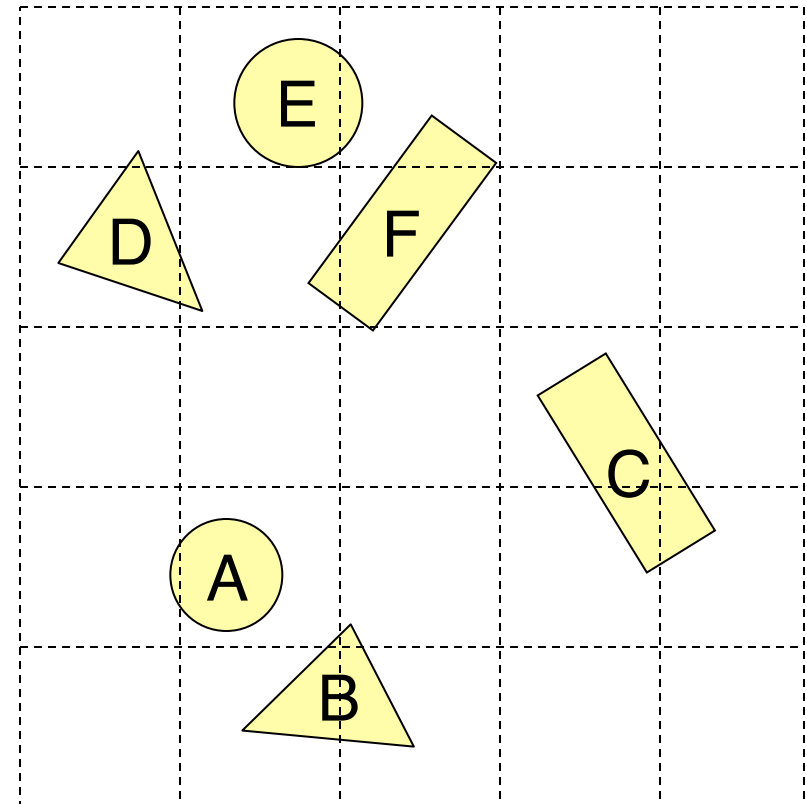



# Uniform Grid

- Trace rays through grid cells
  - Fast
  - Incremental

Only check primitives  
in intersected grid cells

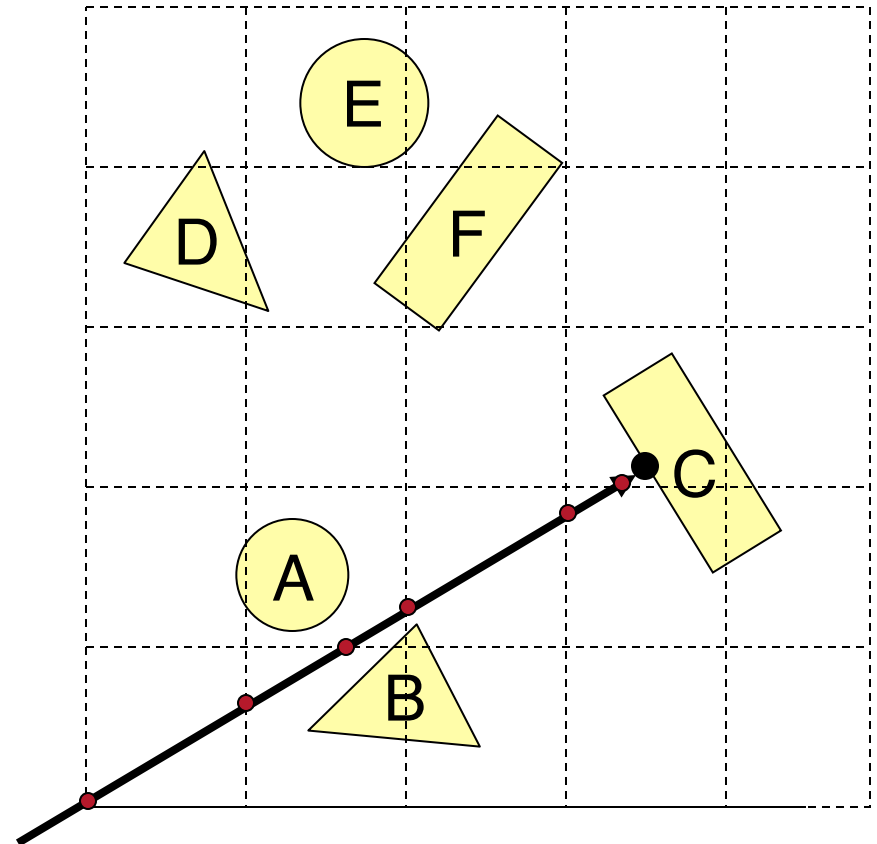



# Uniform Grid

- Potential problem:
  - How choose suitable grid resolution?

Too little benefit  
if grid is too coarse

Too much cost  
if grid is too fine

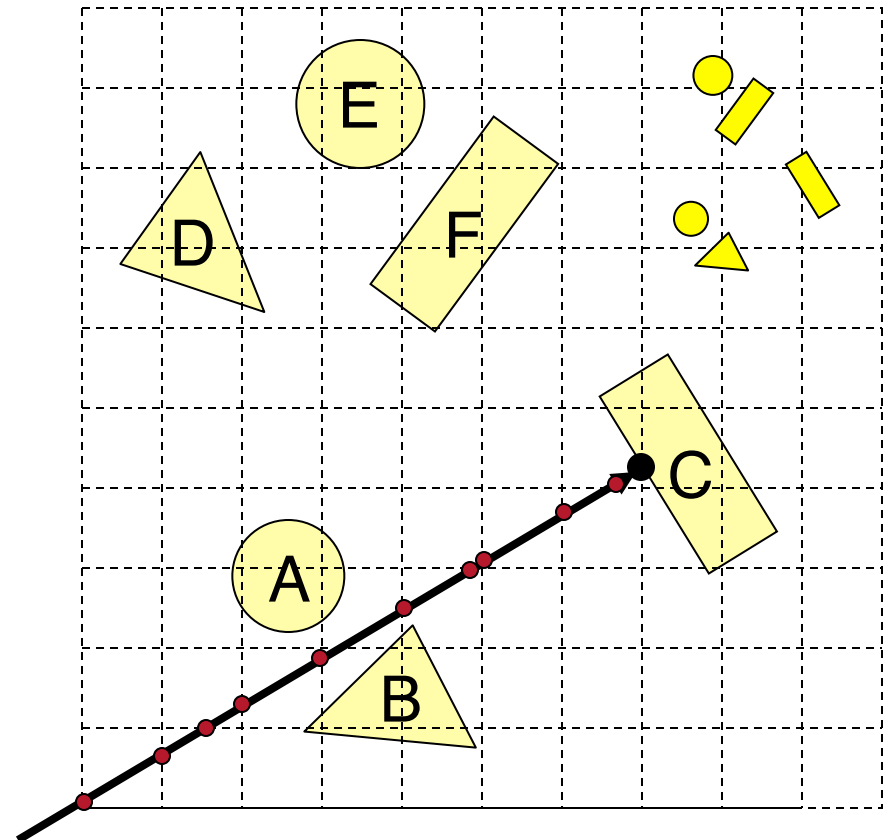



# Ray Intersection

- Ray Intersection
  - Sphere
  - Triangle
  - Box
  - Scene
  
- Ray Intersection Acceleration
  - Bounding volumes
  - Uniform grids
  - **Octrees**
  - BSP trees

# Octree

- Construct adaptive grid over scene
  - Recursively subdivide box-shaped cells into 8 octants
  - Index primitives by overlaps with cells

Generally fewer cells

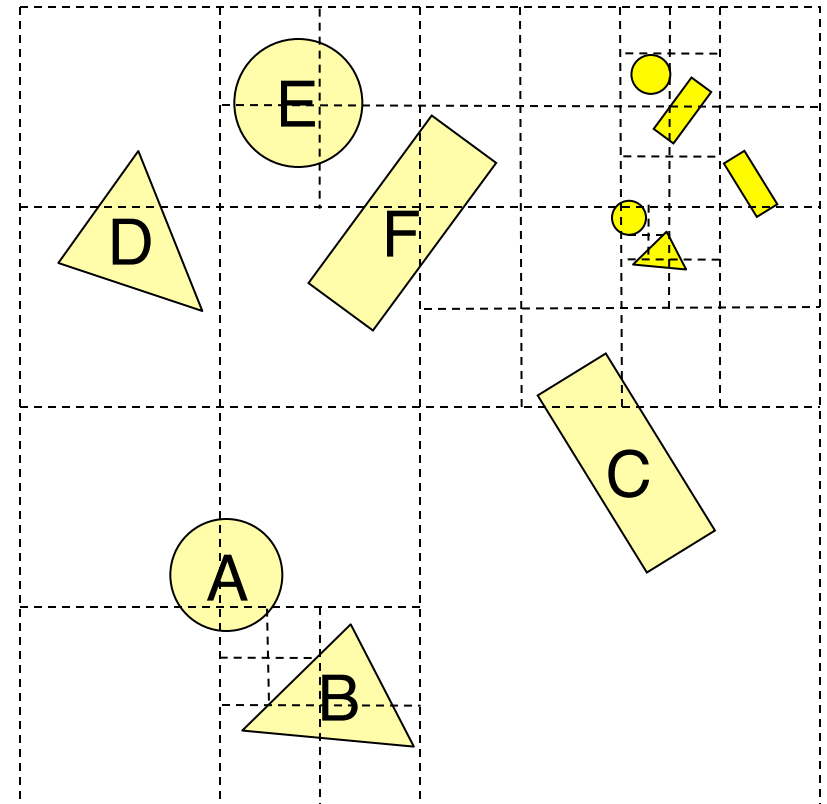

# Octree



- Trace rays through neighbor cells
  - Fewer cells

Trade-off fewer cells for more expensive traversal

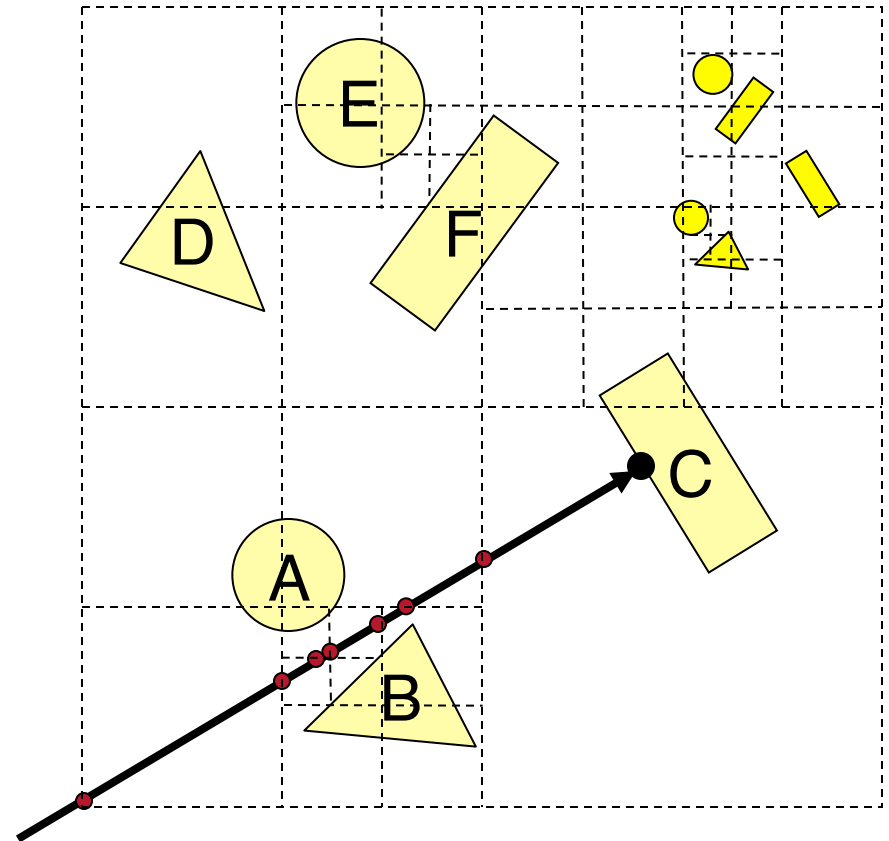



# Octree

- Or, check rays versus octree boxes hierarchically
  - Computing octree boxes while descending tree
  - Sort eight boxes front-to-back at each level
  - Check primitives/children inside box

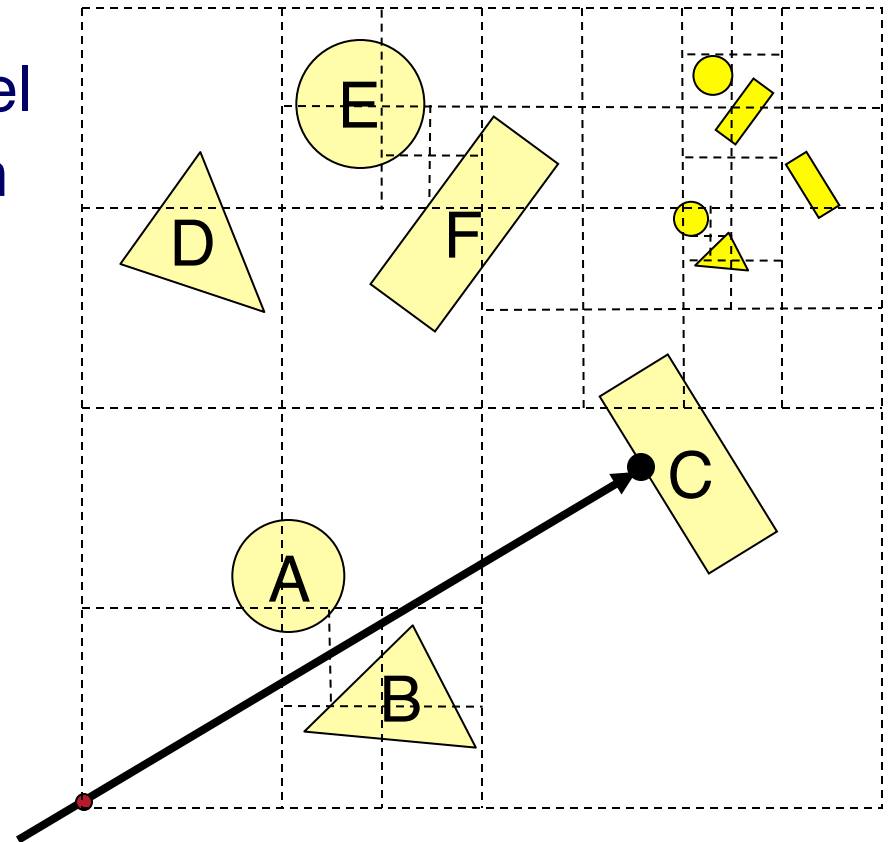



# Ray Intersection

- Ray Intersection
  - Sphere
  - Triangle
  - Box
  - Scene
  
- Ray Intersection Acceleration
  - Bounding volumes
  - Uniform grids
  - Octrees
  - **BSP trees**



# Binary Space Partition (BSP) Tree

- Recursively partition space by planes
  - BSP tree nodes store partition plane and set of polygons lying on that partition plane
  - Every part of every polygon lies on a partition plane

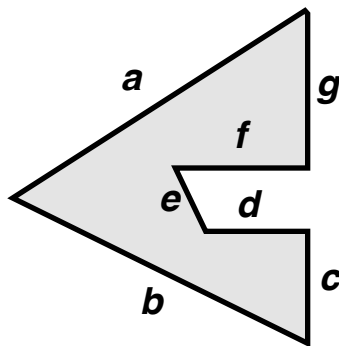

Object

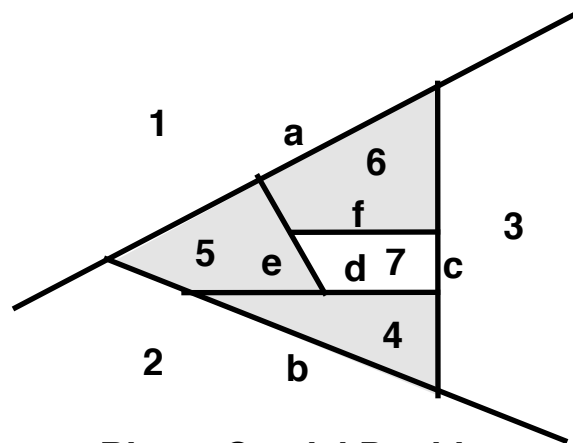

Binary Spatial Partition

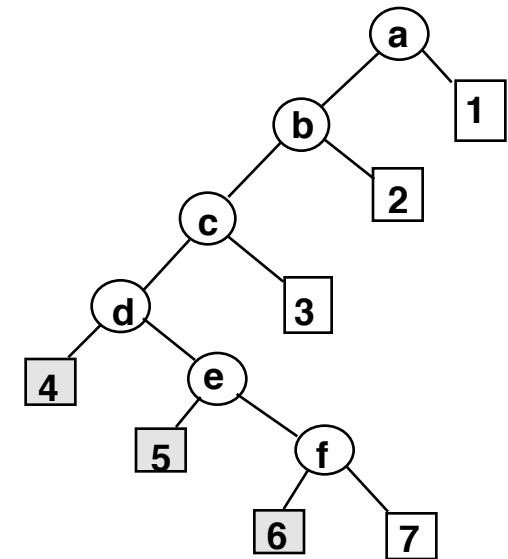

Binary Tree





# Binary Space Partition (BSP) Tree

- Traverse nodes of BSP tree front-to-back
  - Visit halfspace (child node) containing  $P_0$
  - Intersect polygons lying on partition plane
  - Visit halfspace (other child node) not containing  $P_0$

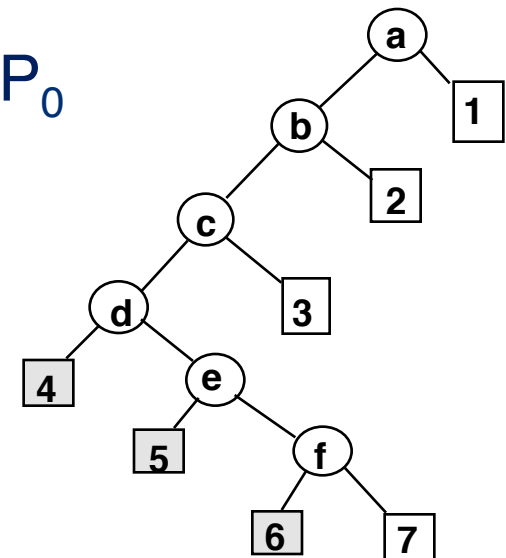
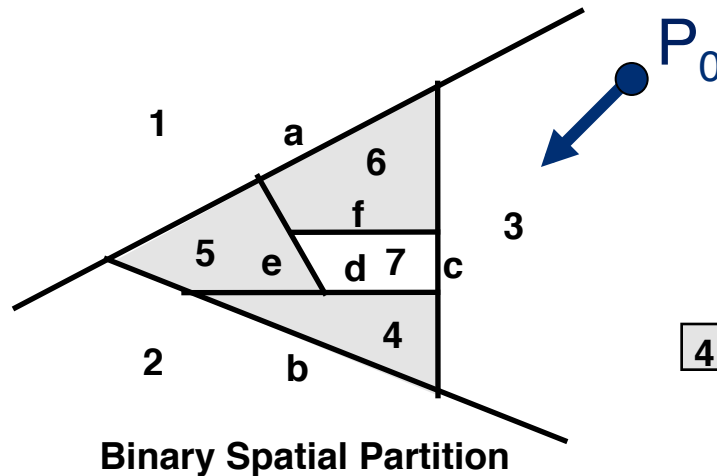
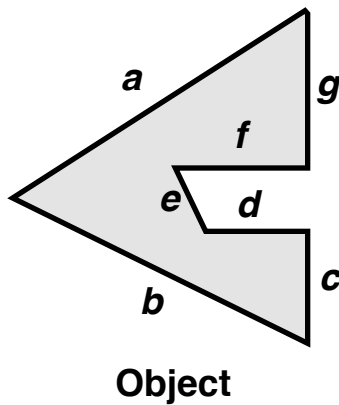

Binary Tree

# Binary Space Partition (BSP) Tree



R3Intersection

```
ComputeBSPIntersection(R3Ray *ray, BspNode *node, double min_t, double max_t)
{
    // Compute parametric value of ray-plane intersection
    t = ray parameter for intersection with split plane of node
    if (t < min_t) || (t < max_t) return no_intersection;

    // Compute side of partition plane that contains ray start point
    int side = (SignedDistance(node->plane, ray.Start()) < 0) ? 0 : 1;
    intersection1 = ComputeBSPIntersection(ray, node->child[side], min_t, t);
    if (intersection1 is a hit) return intersection1;
    intersection2 = ComputePolygonsIntersection(ray, node->polygons);
    if (intersection2 is a hit) return intersection2;
    intersection3 = ComputeBSPIntersection(ray, node->child[1-side], t, max_t);
    return intersection 3;
}
```

# Other Accelerations

- Screen space coherence – check  $> 1$  ray at once
  - Beam tracing
  - Pencil tracing
  - Cone tracing
- Memory coherence
  - Large scenes
- Parallelism
  - Ray casting is “embarrassingly parallelizable”
- etc.

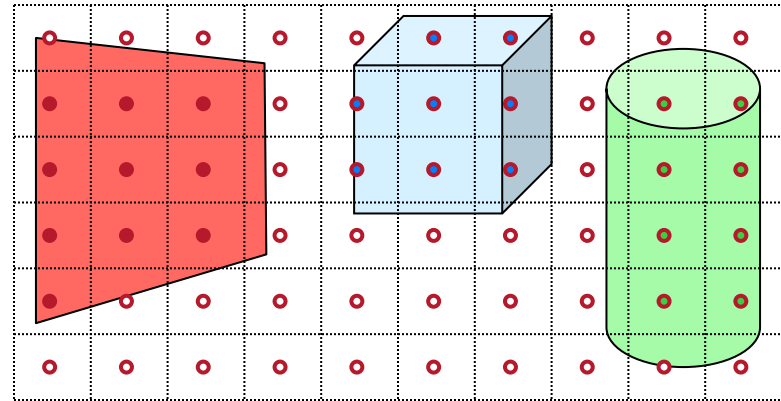



# Acceleration

- Intersection acceleration techniques are important
  - Bounding volume hierarchies
  - Spatial partitions
- General concepts
  - Sort objects spatially
  - Make trivial rejections quick
  - Perform checks hierarchically
  - Utilize coherence when possible

Expected time is sub-linear in number of primitives

# Summary



- Writing a simple ray casting renderer is easy
  - Generate rays
  - Intersection tests
  - Lighting calculations

```
R2Image *RayCast(R3Scene *scene, int width, int height)
{
    R2Image *image = new R2Image(width, height);
    for (int i = 0; i < width; i++) {
        for (int j = 0; j < height; j++) {
            R3Ray ray = ConstructRayThroughPixel(scene->camera, i, j);
            R3Rgb radiance = ComputeRadiance(scene, &ray);
            image->SetPixel(i, j, radiance);
        }
    }
    return image;
}
```

# Heckbert's Business Card Ray Tracer



- ```
typedef struct{double x,y,z}vec;vec U,black,amb={.02,.02,.02};struct sphere{ vec cen,color;
double rad,kd,ks,kt,kl,ir}*s,*best,sph[]={0.,6.,.5,1.,1.,1.,.9, .05,.2,.85,0.,1.7,-1.,8.,-.5,1.,.5,.2,1.,
.7,.3,0.,.05,1.2,1.,8.,-.5,.1.,8.,8, 1.,.3,.7,0.,0.,1.2,3.,-6.,15.,1.,.8,1.,7.,0.,0.,0.,.6,1.5,-3.,-3.,12.,
.8,1., 1.,5.,0.,0.,0.,.5,1.5,};yx;double u,b,tmin,sqrt(),tan();double vdot(A,B)vec A ,B;{return A.x
*B.x+A.y*B.y+A.z*B.z;}vec vcomb(a,A,B)double a;vec A,B;{B.x+=a* A.x;B.y+=a*A.y;B.z+=a*A.z;
return B;}vec vunit(A)vec A;{return vcomb(1./sqrt( vdot(A,A)),A,black);}struct sphere*intersect
(P,D)vec P,D;{best=0;tmin=1e30;s= sph+5;while(s-->sph)b=vdot(D,U=vcomb(-1.,P,s->cen)),
u=b*b-vdot(U,U)+s->rad*s ->rad,u=u>0?sqrt(u):1e31,u=b-u>1e-7?b-u:b+u,tmin=u>=1e-7&&
u<tmin?best=s,u: tmin;return best;}vec trace(level,P,D)vec P,D;{double d,eta,e;vec N,color;
struct sphere*s,*l;if(!level--)return black;if(s=intersect(P,D));else return amb;color=amb;eta=
s->ir;d= -vdot(D,N=vunit(vcomb(-1.,P=vcomb(tmin,D,P),s->cen )));if(d<0)N=vcomb(-1.,N,black),
eta=1/eta,d= -d;l=sph+5;while(l-->sph)if(((e=l ->kl*vdot(N,U=vunit(vcomb(-1.,P,l->cen))))>0&&
intersect(P,U)==l)color=vcomb(e ,l->color,color);U=s->color;color.x*=U.x;color.y*=U.y;color.z
*=U.z;e=1-eta* eta*(1-d*d);return vcomb(s->kt,e>0?trace(level,P,vcomb(eta,D,vcomb(eta*d-
sqrt( e),N,black)):black,vcomb(s->ks,trace(level,P,vcomb(2*d,N,D)),vcomb(s->kd, color,vcomb
(s->kl,U,black)))));}main(){printf("%d %d\n",32,32);while(yx<32*32) U.x=yx%32-32/2,U.z=32/2-
yx++/32,U.y=32/2/tan(25/114.5915590261),U=vcomb(255., trace(3,black,vunit(U)),black),printf
("%%.0f %.0f %.0f\n",U);}/*minray!*/
```

# Next Time is Illumination!

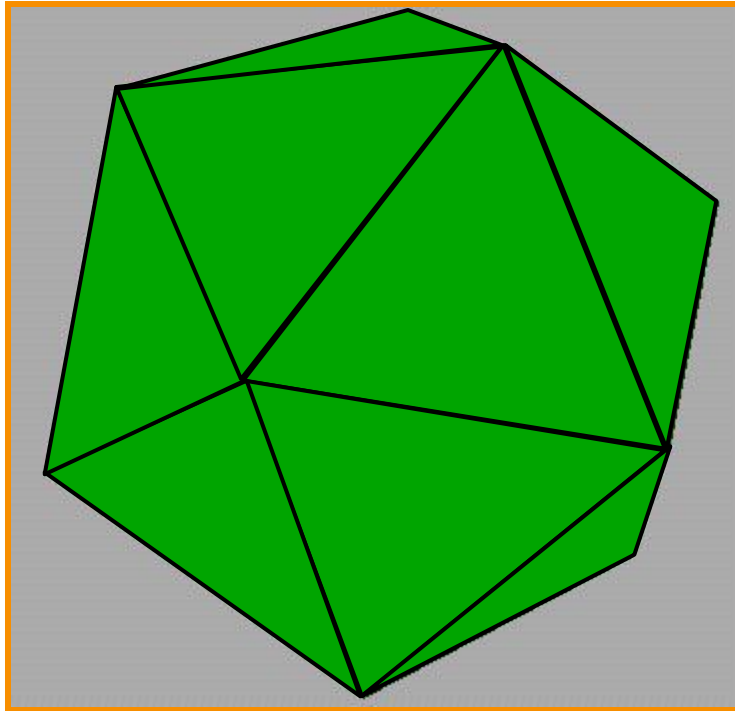

Without Illumination

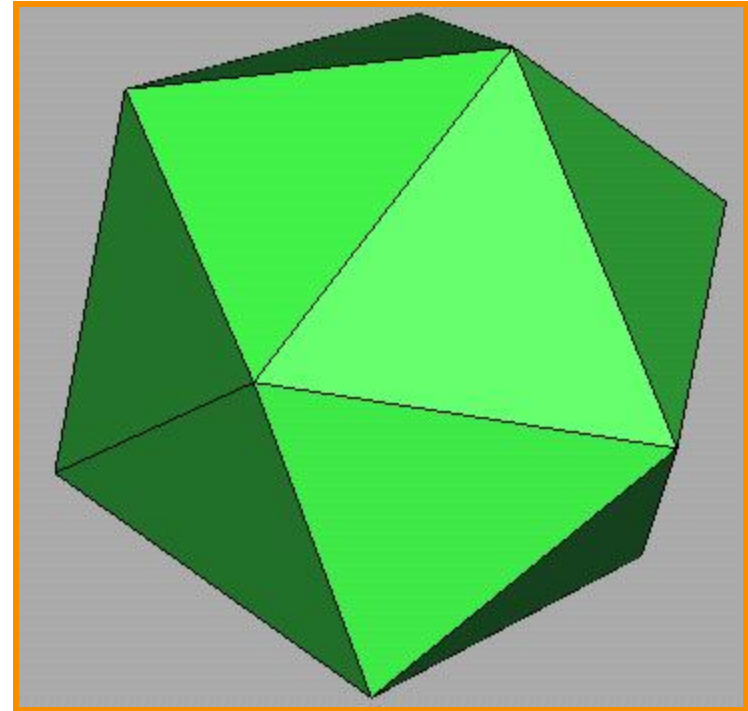

With Illumination