

Against logic there is no armor like ignorance.

Laurence J. Peter (1919 - 1988)

Logic merely enables one to be wrong with authority.

Doctor Who

Q1) Consider the following facts:

Matt will go to the party if John and Brian go. Brian will go if Karen goes or Sue doesn't go. Sue will go if John doesn't. Karen will go if Sue does.

Represent whether or not Matt will go to the party as a truth table, boolean circuit, and boolean expression. Simplify your boolean expression as much as you can.

Q2) What problem can arise when combinational circuits are allowed to have cycles?

Q3) In class we saw that every Boolean function can be computed using a Boolean circuit that consists only of AND, OR and NOT gates. Briefly argue that in fact a single type of gate suffices to build all Boolean circuits: the NAND gate. This is a gate with two inputs and has the following truth table:

<i>A</i>	<i>B</i>	<i>A NAND B</i>
0	0	1
0	1	1
1	0	1
1	1	0

Q4) (From Ray Smullyan) On the last of the one thousand and one nights, the Sultan of Arabia was going to finally send Scheherazade to her death. As her final wish, she begged him to answer one question with a Yes or No. The Sultan agreed, saying "I always give a straight Yes/No answer, and always stand by what I say." The wily Scheherazade -- well-versed in Boolean logic -- then asked a tricky question. The Sultan pondered his possible answers, and realized that no matter how he answered, he would be forced to spare Scheherazade's life.

Your task is to figure out Scheherazade's question. Hint: It consists of asking whether or not a certain boolean expression is true. It has two variables: K (which is 1 if and only if the King answers "yes" to the entire question) and S (which is 1 if and only if the King decides to spare Scheherazade).

Q5) The following synchronous circuit represents a finite state machine:

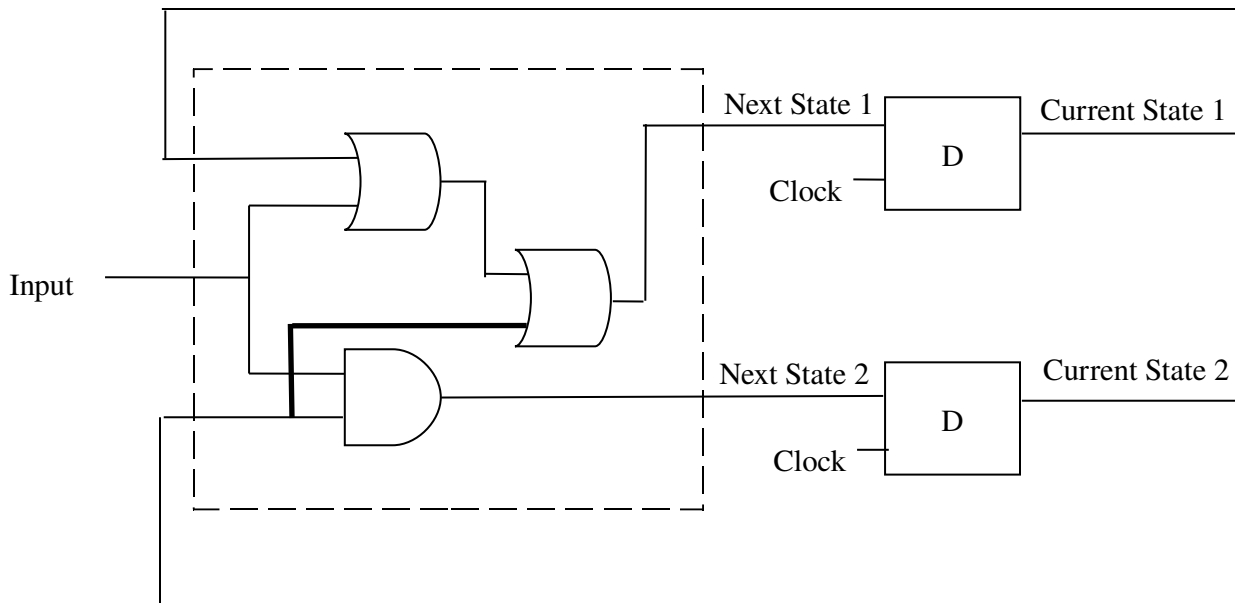

The boxes labeled "D" are D flip-flops.

- Write down the truth table, describing the next state produced for each current state and input bit.
- Draw the transition diagram for the FSM.