

Review of 3D Object Representations

**Thomas Funkhouser
Princeton University
COS 598B, Spring 2000**

Goal

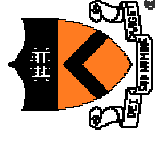

- Develop algorithms for analysis of 3D models

- Reconstruction
- Segmentation
- Feature detection
- Labeling
- Matching
- Classification
- Retrieval
- Recognition
- Clustering

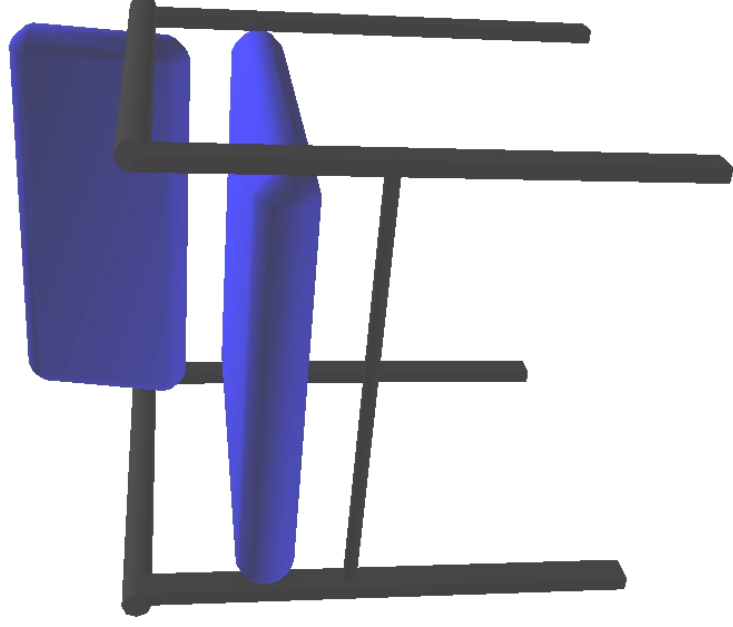

Different methods for different object representations

3D Objects

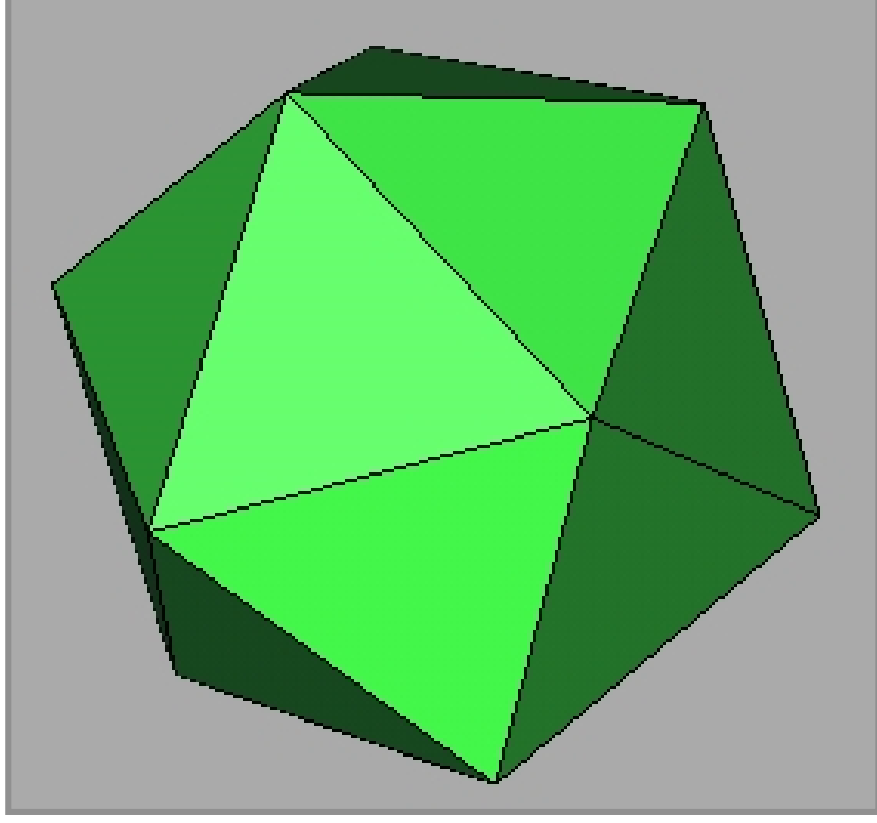
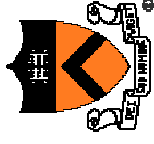

How can this object be represented in a computer?

3D Objects

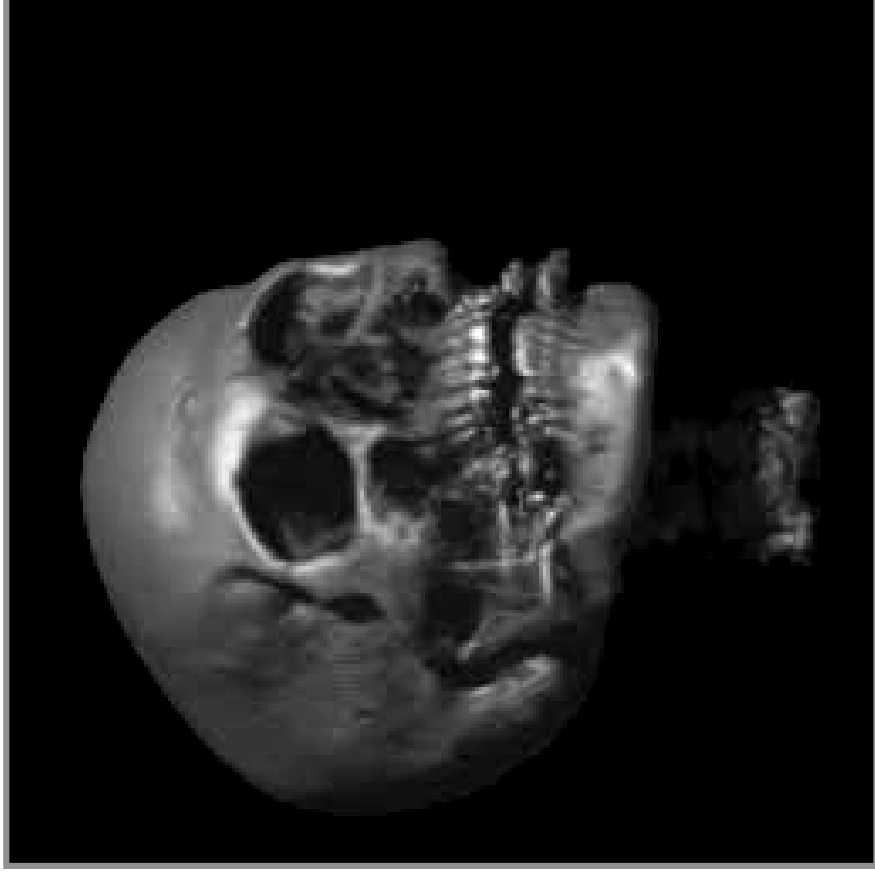
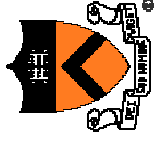

Stanford Graphics Laboratory

How about this one?

3D Objects

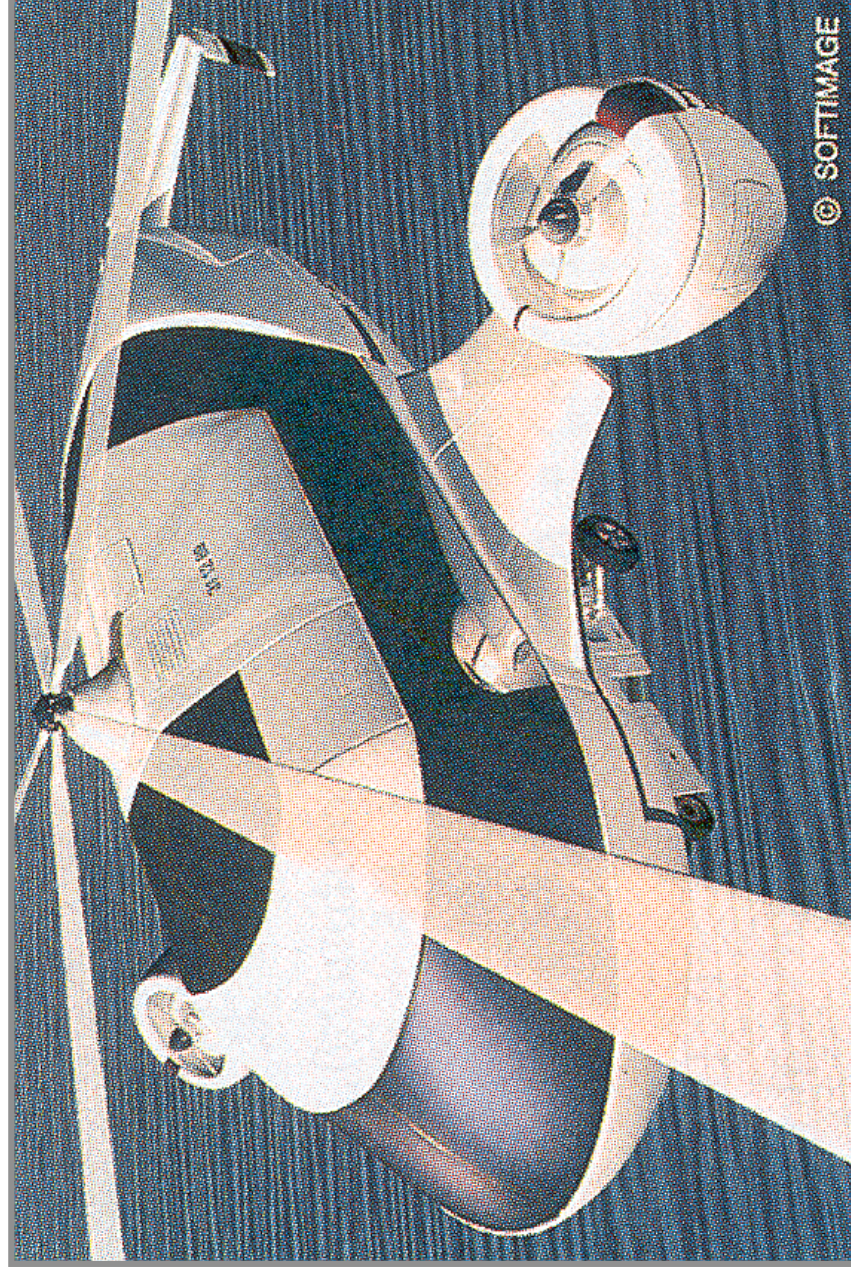
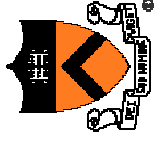

This one?

H&B Figure 10.46

3D Objects

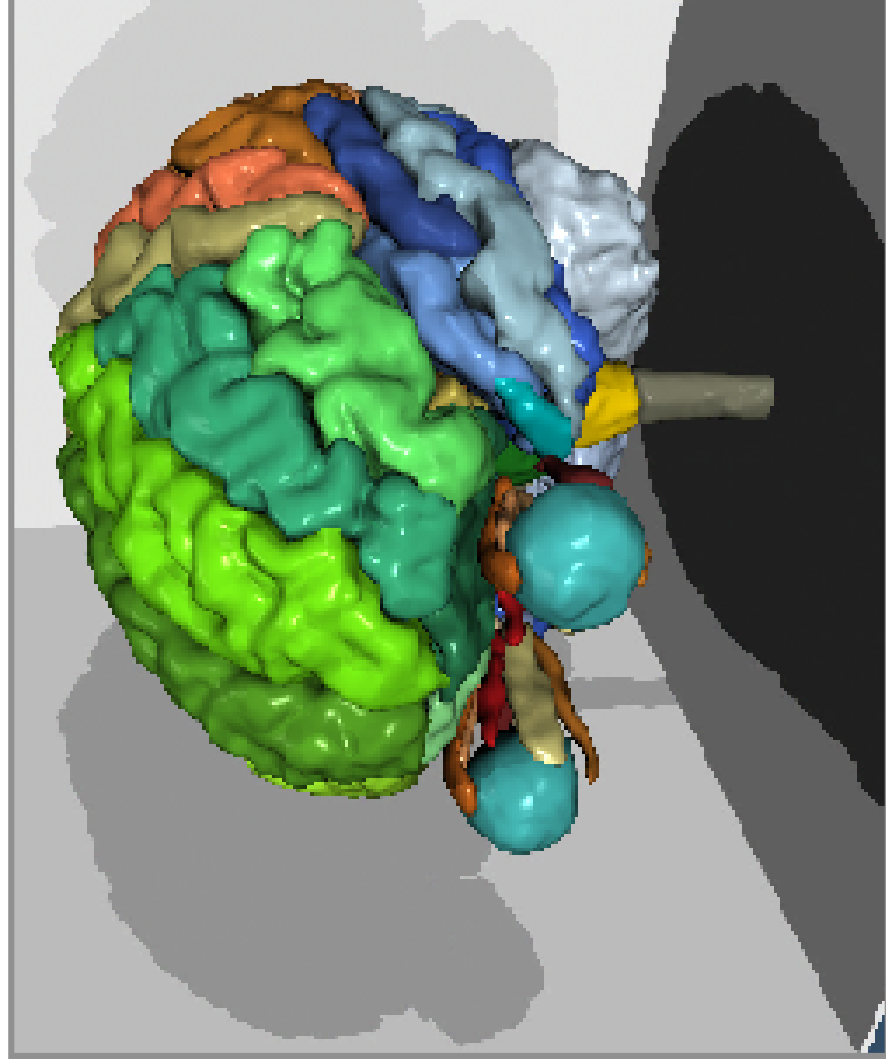
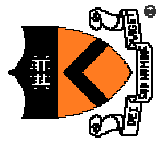

Lorensen

This one?

3D Objects

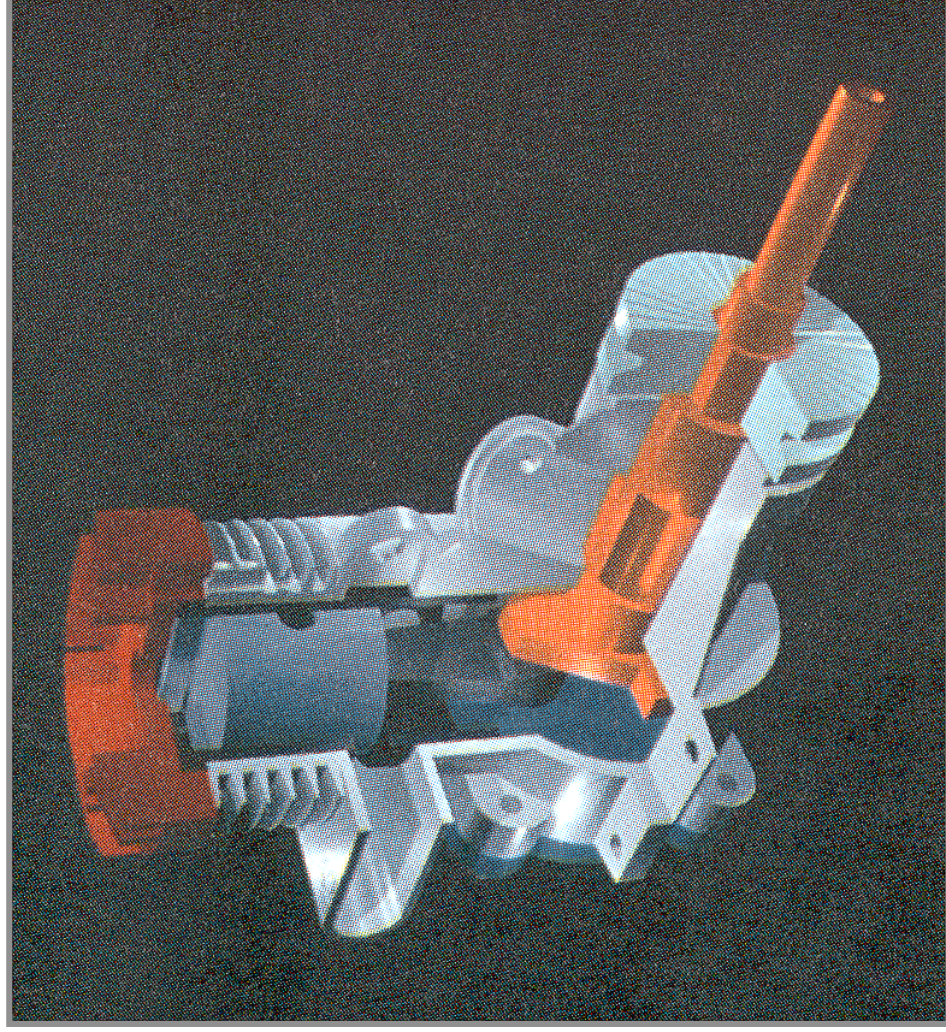
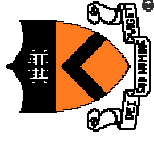

This one?

H&B Figure 9.9

3D Objects

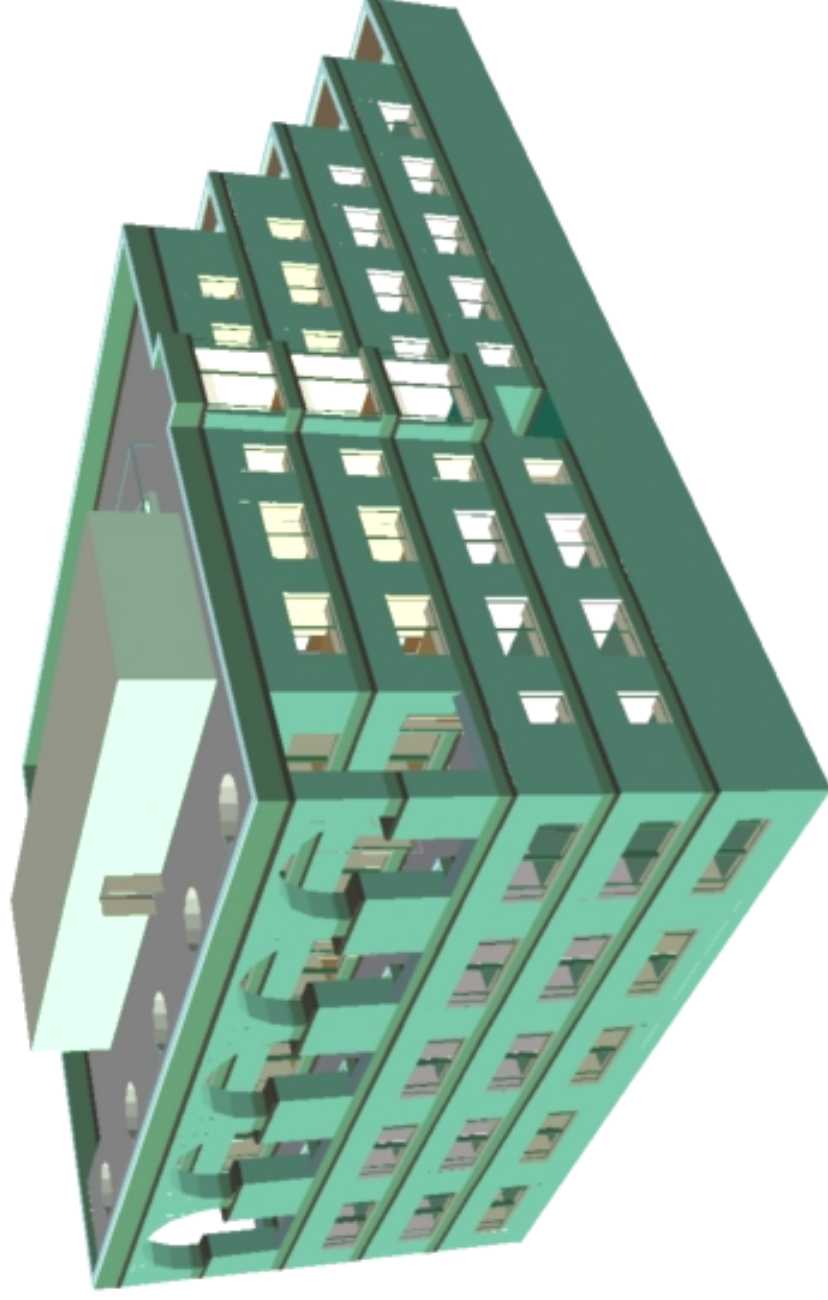
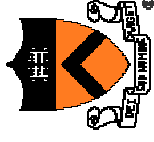

This one?

3D Object Representations

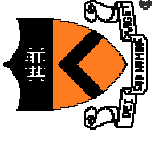

- **Raw data**
 - Point cloud
 - Range image
 - Polygon soup
- **Solids**
 - Voxels
 - BSP tree
 - Cell complex
- **Surfaces**
 - Mesh
 - Subdivision
 - Parametric
 - Implicit
- **High-level structures**
 - CSG
 - Constrained blocks
 - Generative model
 - Skeleton
 - Sweep
 - Scene graph

Point Cloud

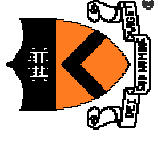

- Unstructured set of 3D point samples
 - Acquired from range finder, computer vision, etc

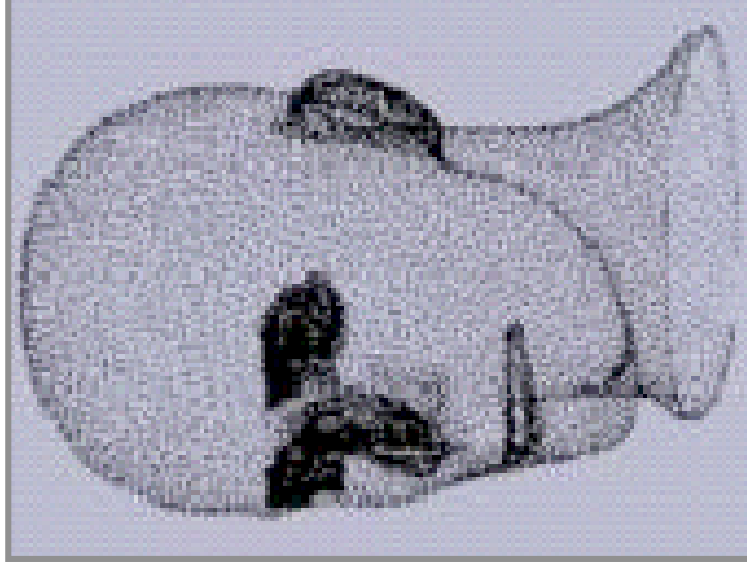

Hoppe

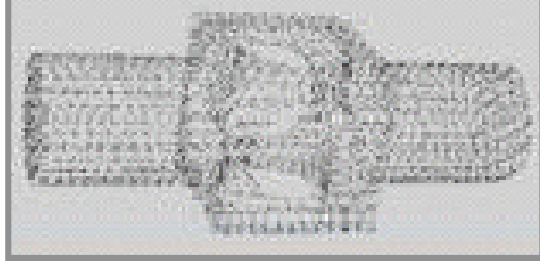

Hoppe

Range Image

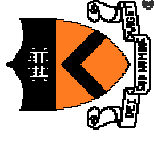

- Set of 3D points mapping to pixels of depth image
 - Acquired from range scanner

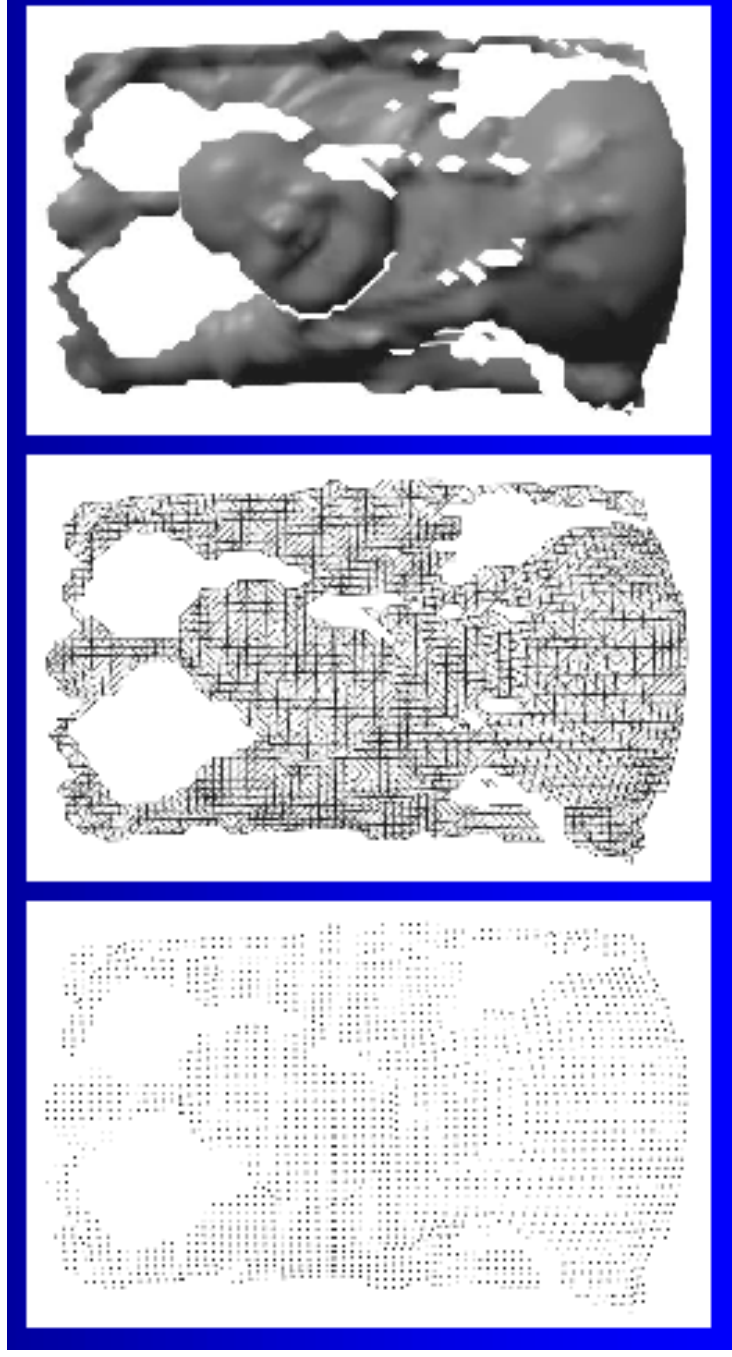

Range Image

Tessellation

Range Surface

Mesh

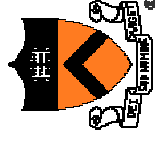

- Connected set of polygons (usually triangles)
 - May not be closed

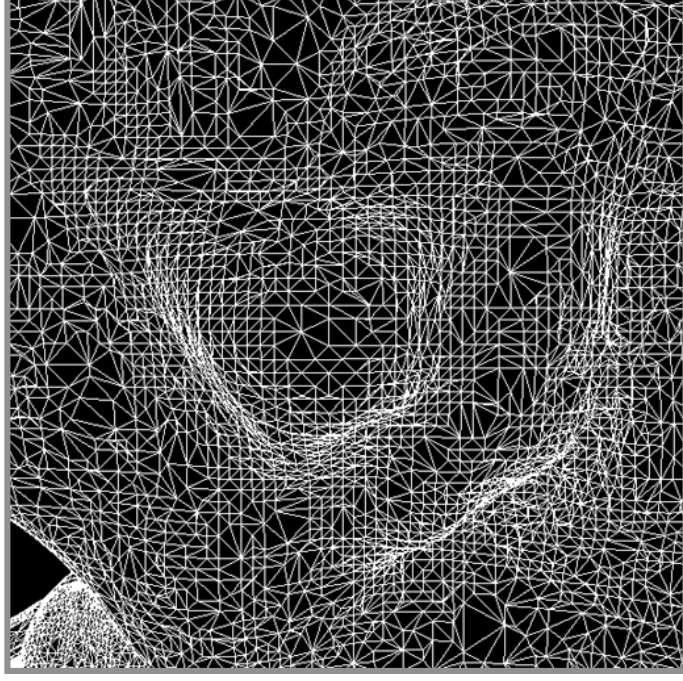

Subdivision Surface

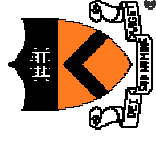

- Coarse mesh & subdivision rule
 - Define smooth surface as limit of sequence of refinements

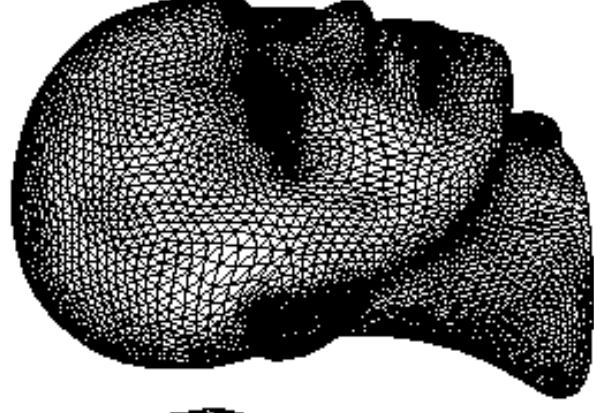
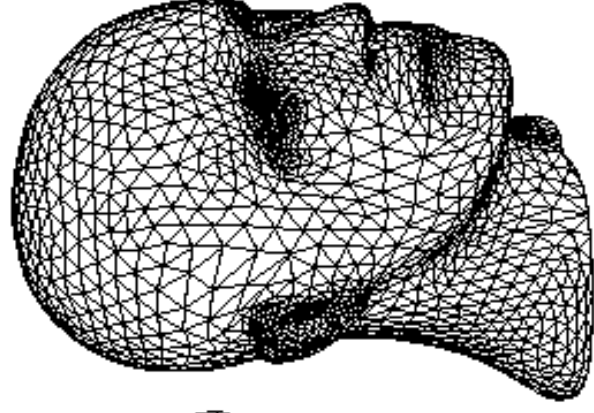
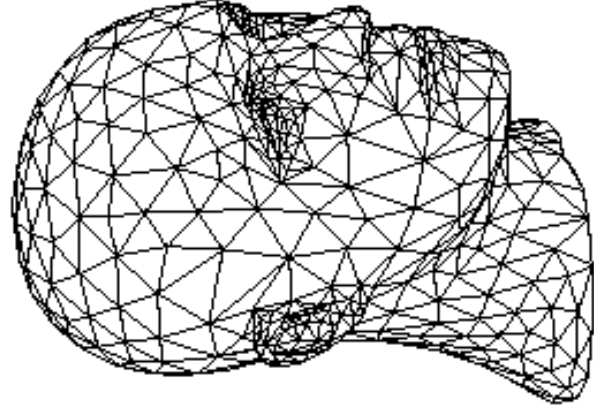

Polygon Soup

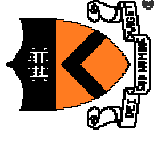

- Unstructured set of polygons
 - Created with interactive modeling systems?

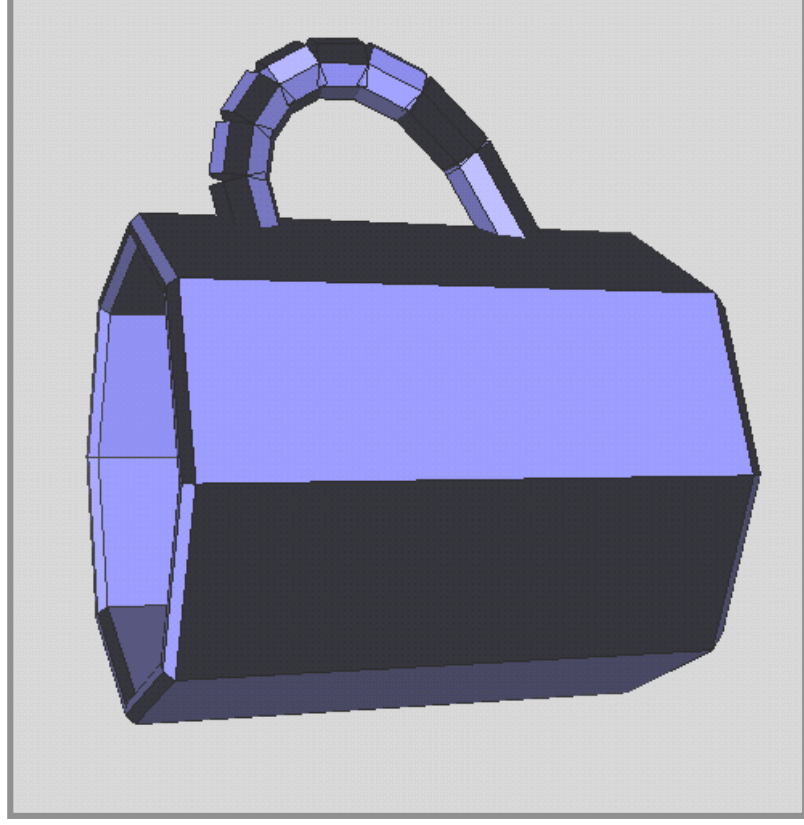

Larson

Parametric Surface

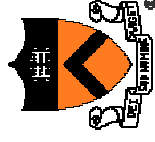

- Tensor product spline patches
 - Careful constraints to maintain continuity

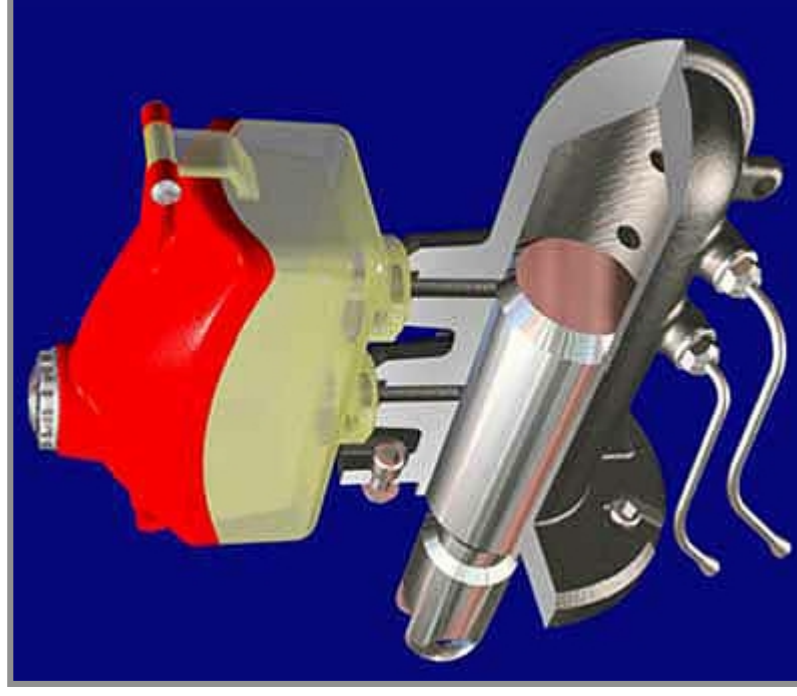
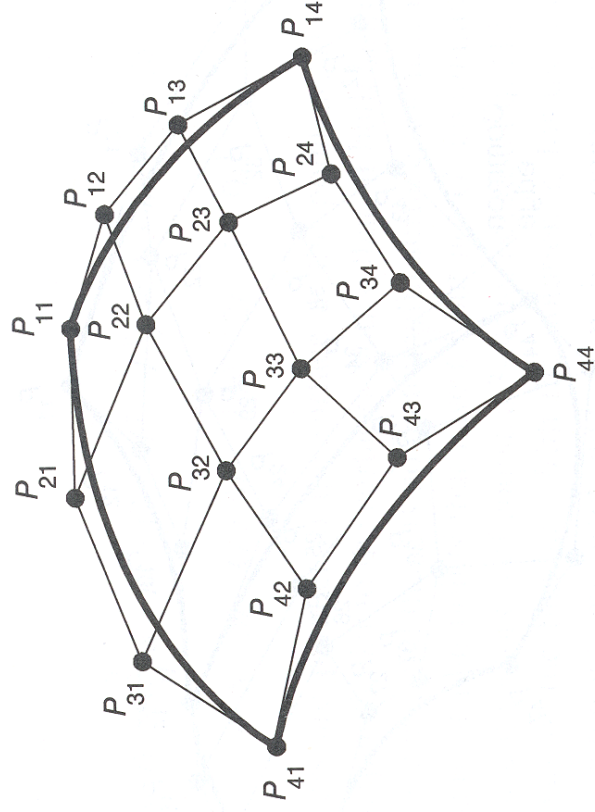

FvDFH Figure 11.44

Implicit Surface

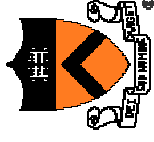

- Points satisfying: $F(x,y,z) = 0$

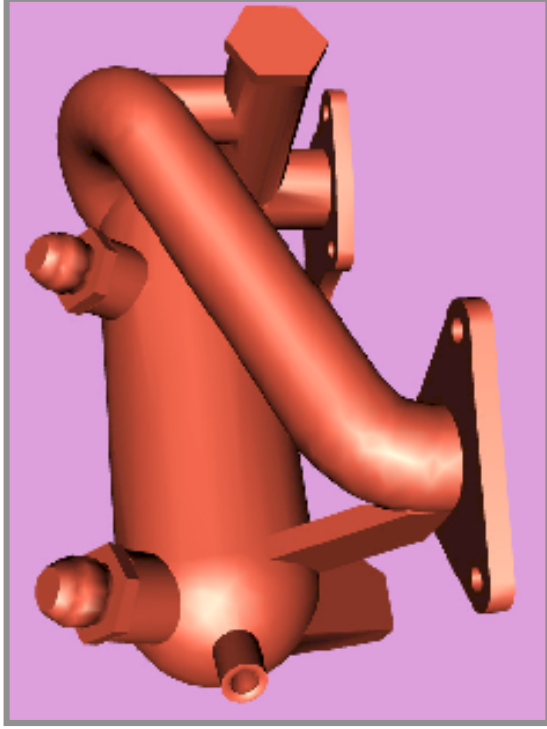

Polygonal Model

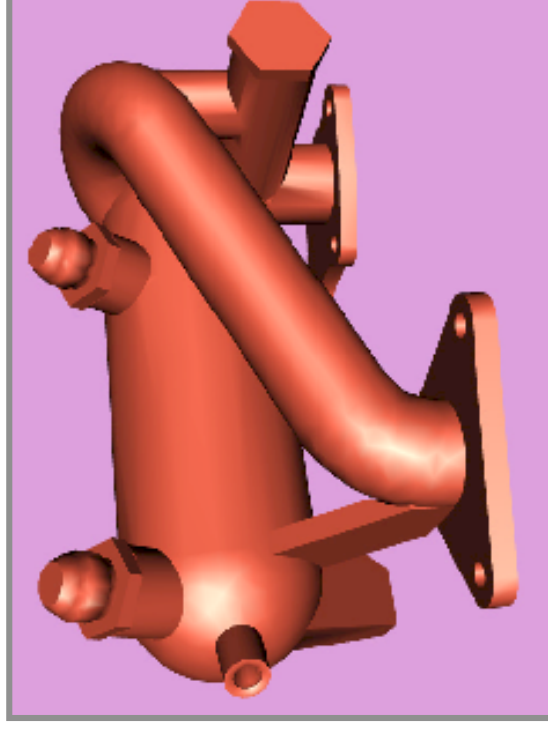

Implicit Model

Bill Lorensen
SIGGRAPH 99
Course #4 Notes

3D Object Representations

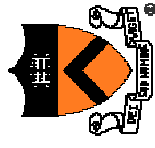

- **Raw data**
 - Point cloud
 - Range image
 - Polygon soup
- **Solids**
 - Voxels
 - BSP tree
 - Cell complex
- **Surfaces**
 - Mesh
 - Subdivision
 - Parametric
 - Implicit
- **High-level structures**
 - CSG
 - Constrained blocks
 - Generative model
 - Skeleton
 - Sweep
 - Scene graph

Voxels

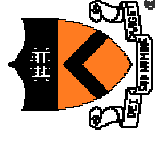

- Uniform grid of volumetric samples
 - Acquired from CAT, MRI, etc.

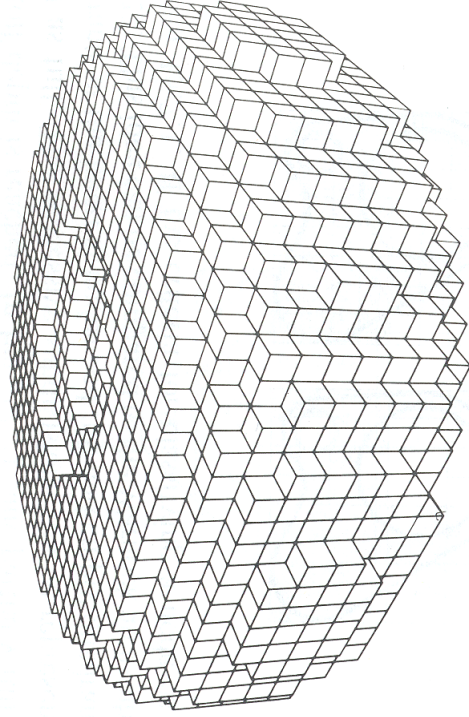

FvDFH Figure 12.20

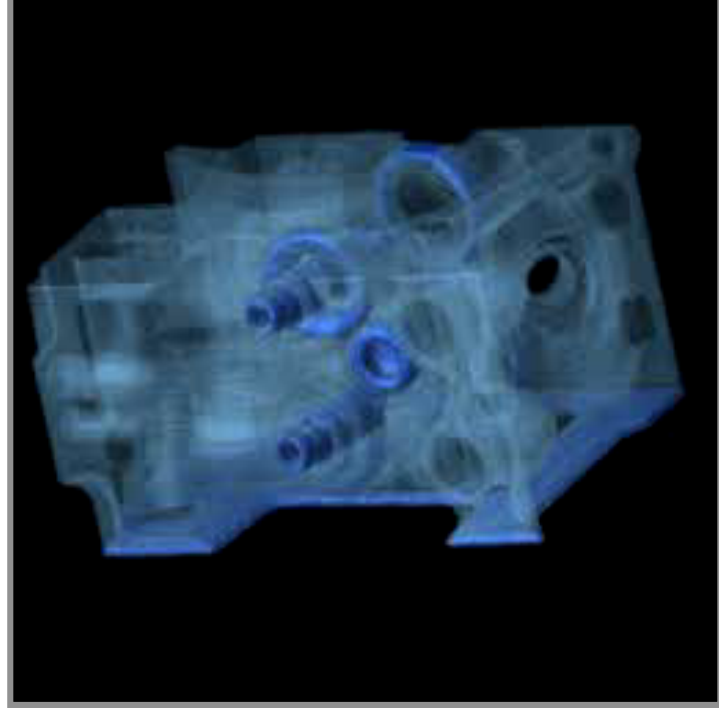

Stanford Graphics Laboratory

BSP Tree

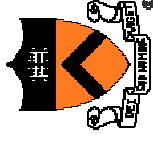

- Binary space partition with solid cells labeled
 - Constructed from polygonal representations

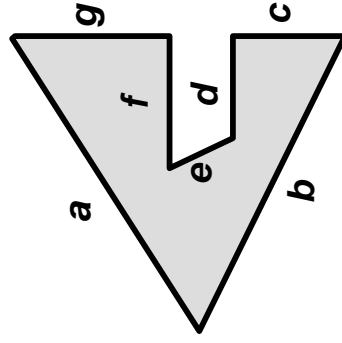

Object

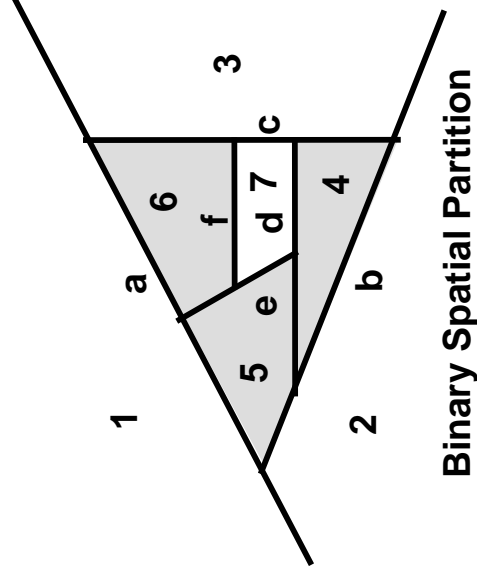

Binary Spatial Partition

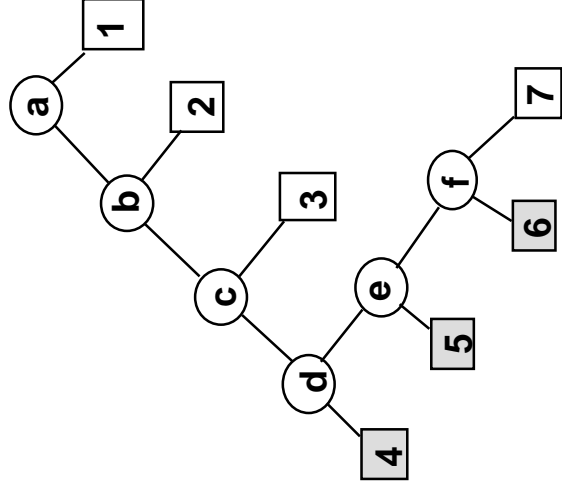

Binary Tree

Cell Complex

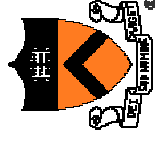

- Arrangement of polyhedral cells with adjacent cells linked and solid cells labeled
 - e.g., adjacency graph of BSP leaf cells

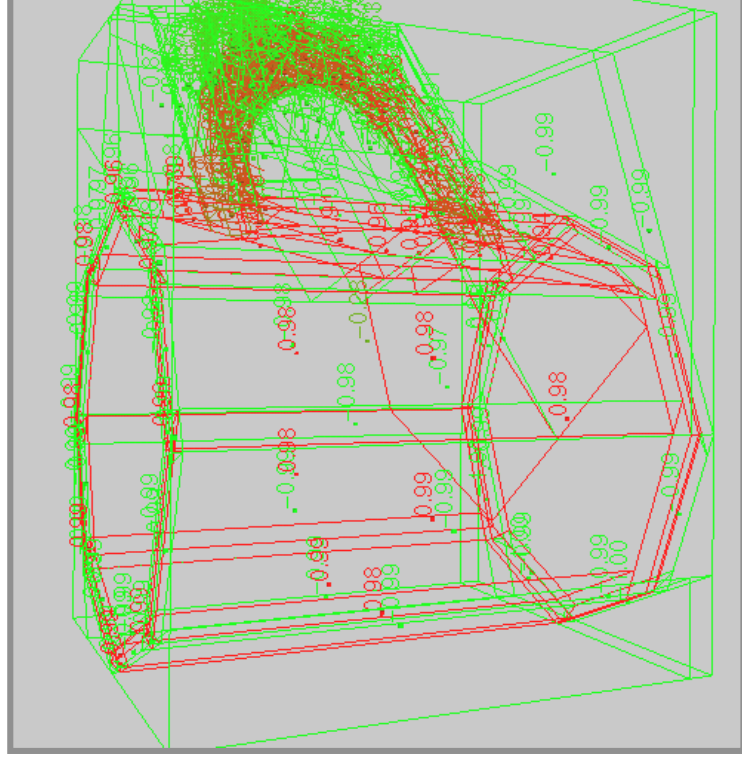

Murali

Taxonomy of 3D Representations

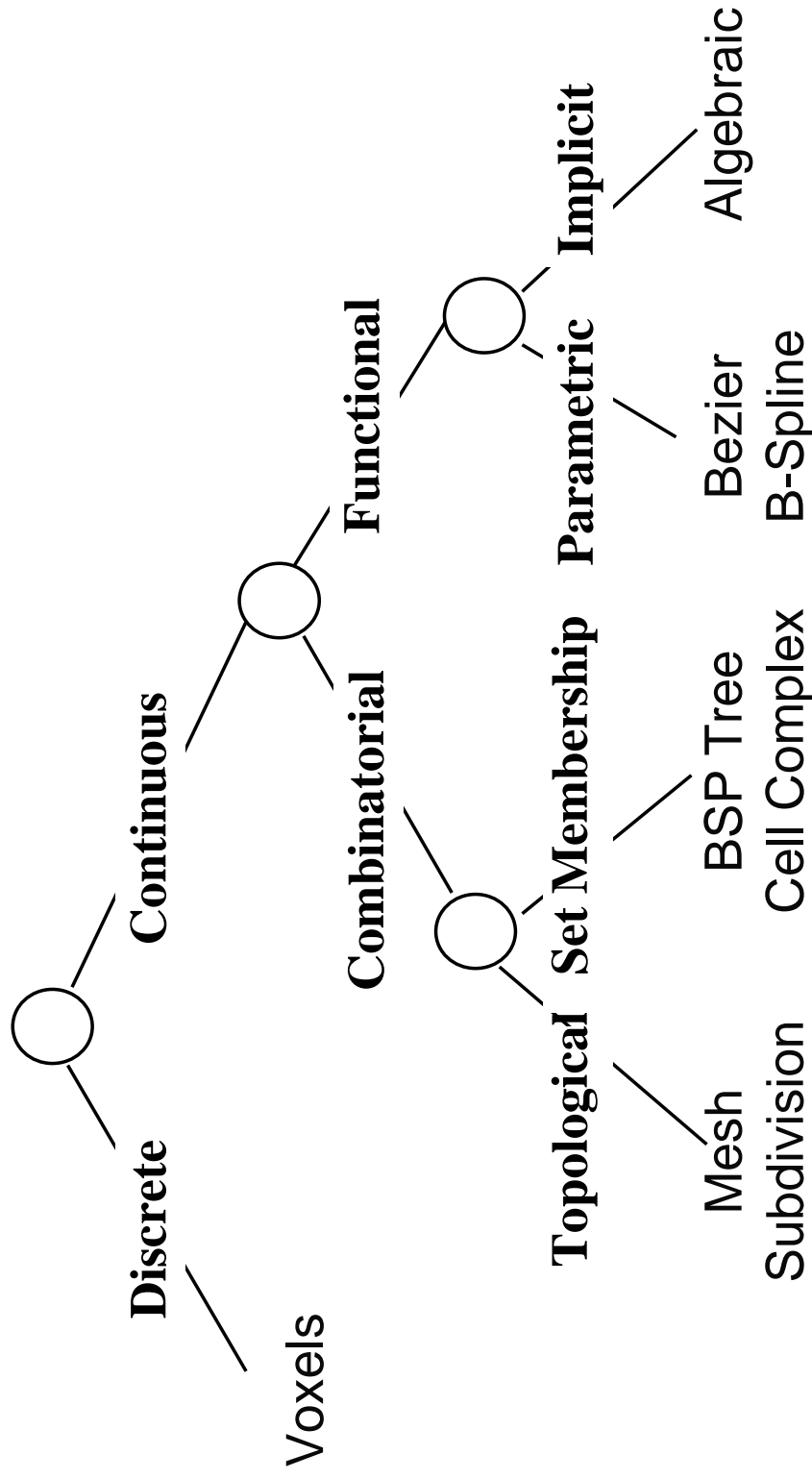
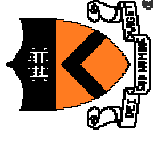

3D Object Representations

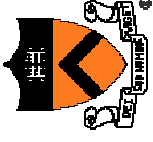

- **Raw data**
 - Point cloud
 - Range image
 - Polygon soup
- **Solids**
 - Voxels
 - BSP tree
 - Cell complex
- **Surfaces**
 - Mesh
 - Subdivision
 - Parametric
 - Implicit
- **High-level structures**
 - CSG
 - Constrained blocks
 - Generative model
 - Skeleton
 - Sweep
 - Scene graph

CSG

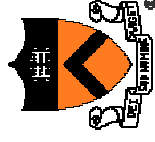

- Hierarchy of boolean set operations (union, difference, intersect) applied to simple shapes

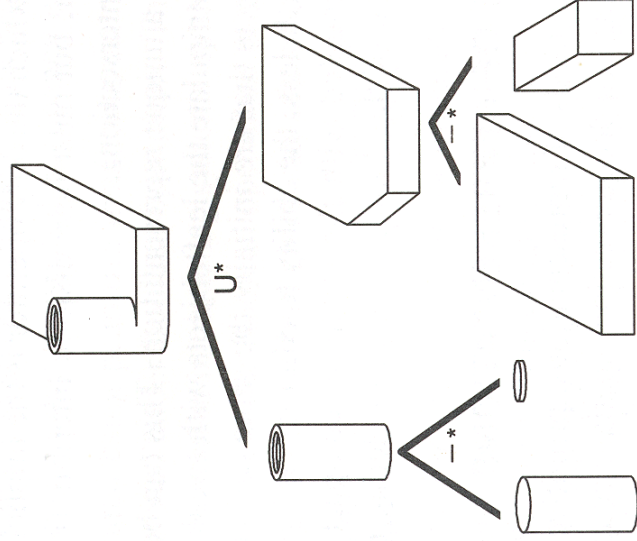

FvDFH Figure 12.27

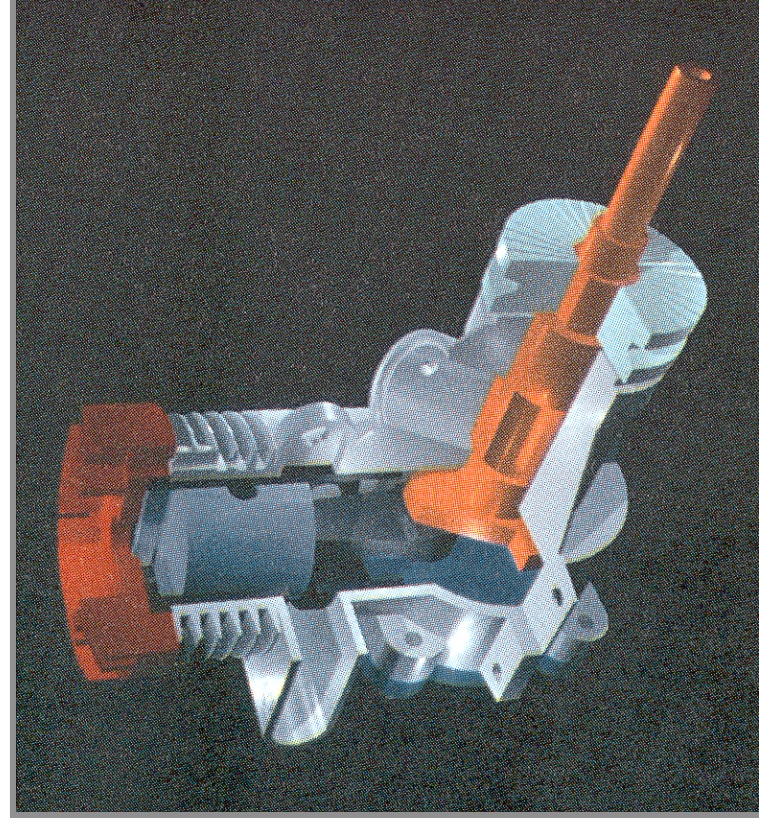

H&B Figure 9.9

Constrained Blocks

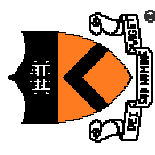

- Set of simple shapes with geometric constraints

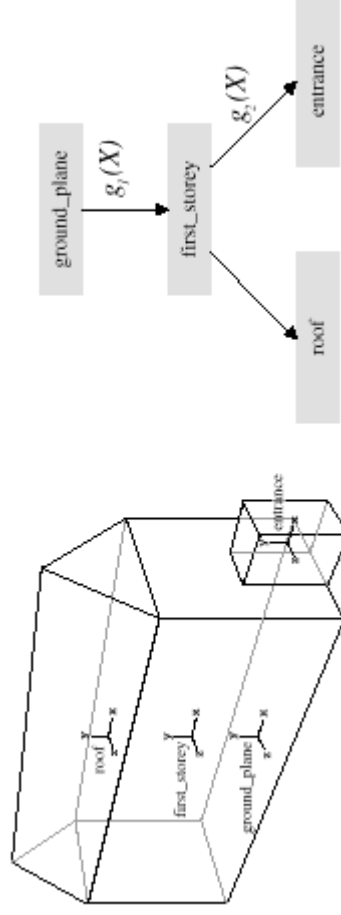
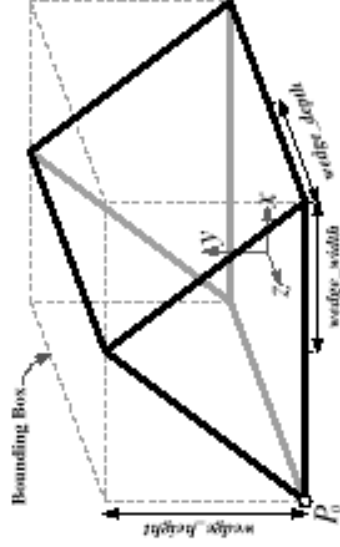

Debevec et al.

Generative Model

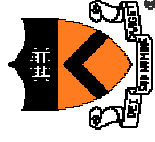

- Hierarchy of modifying curves

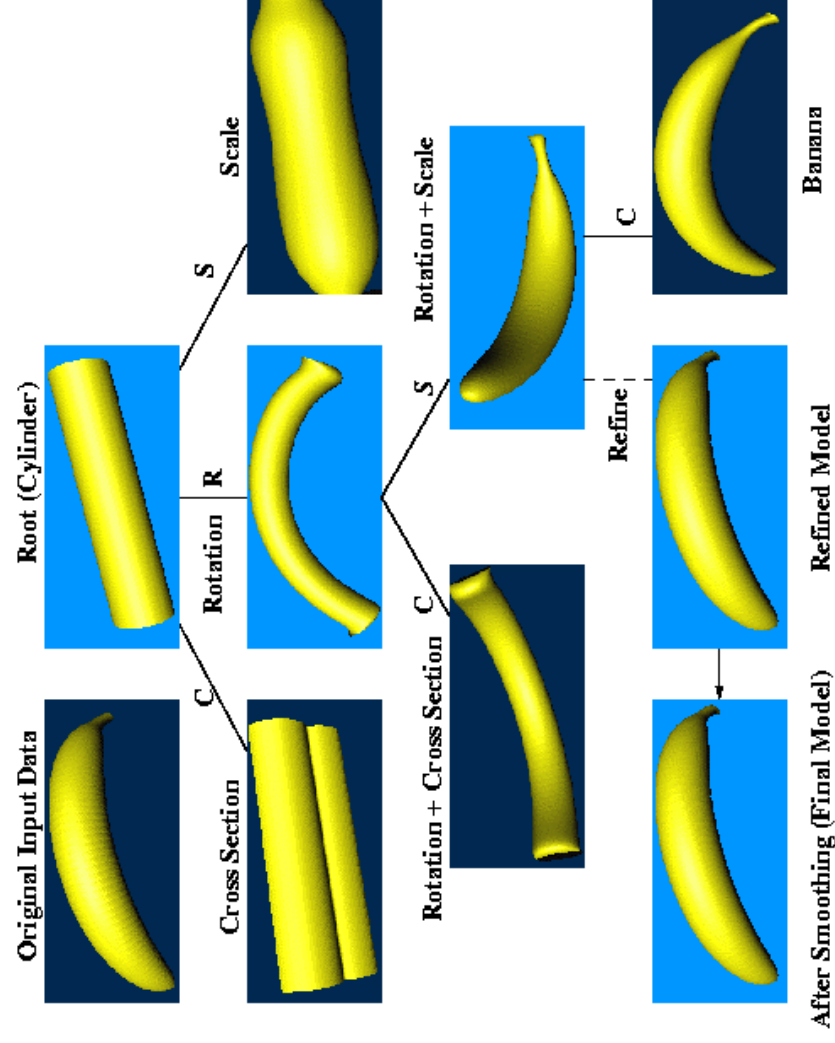

Ramamoorthy et al.

Skeleton

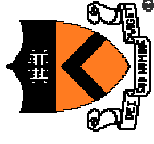

- Graph of curves with radii

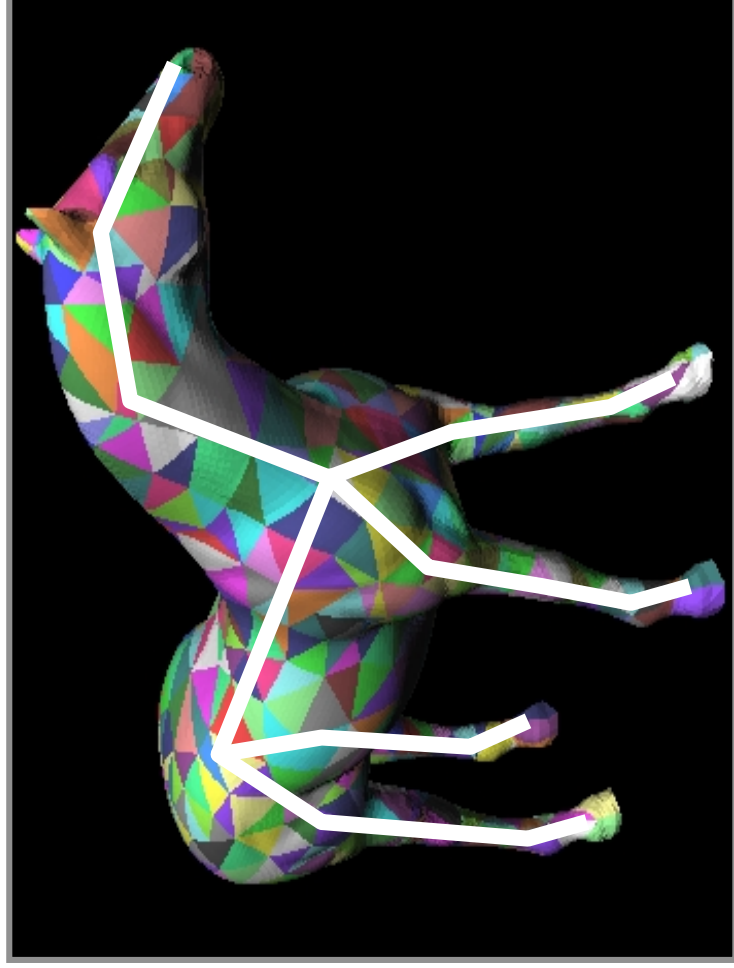

Stanford Graphics Laboratory

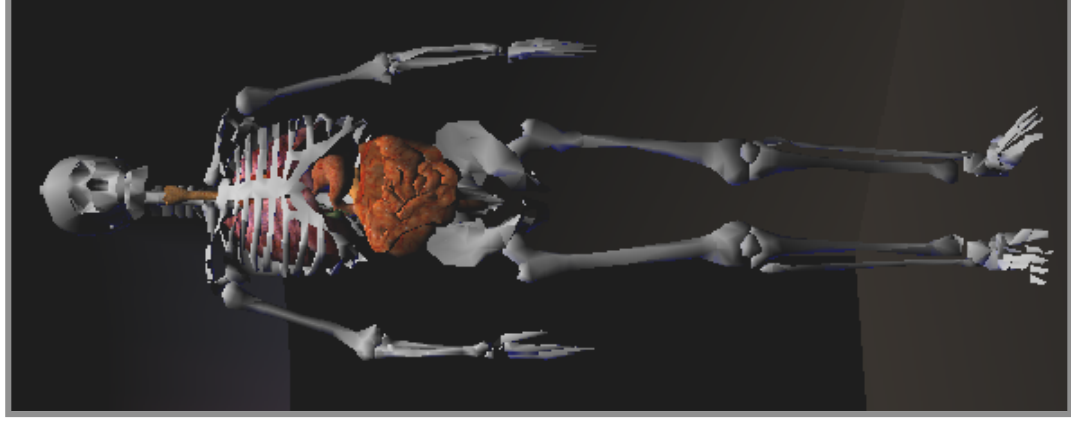

SGI

Sweep

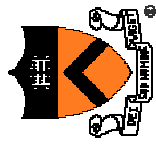

- Surface swept by curve along trajectory

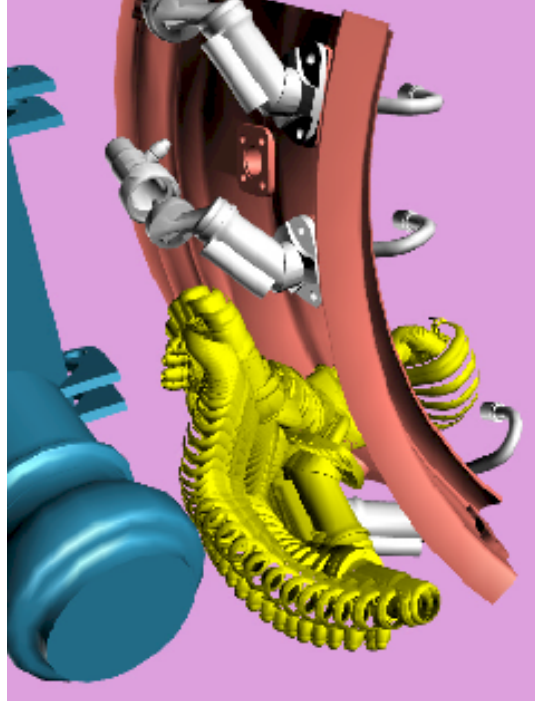

Removal Path

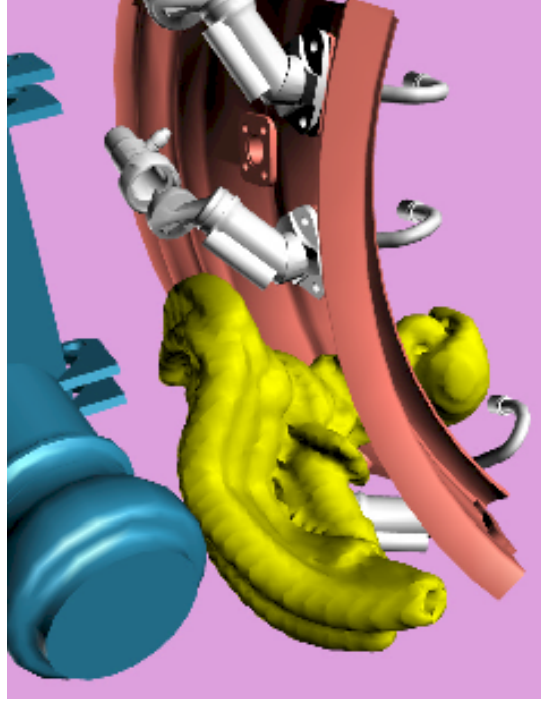

Sweep Model

Bill Lorenzen
SIGGRAPH 99
Course #4 Notes

Scene Graph

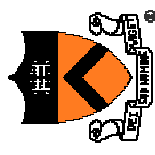

- Union of objects at leaf nodes



Bell Laboratories

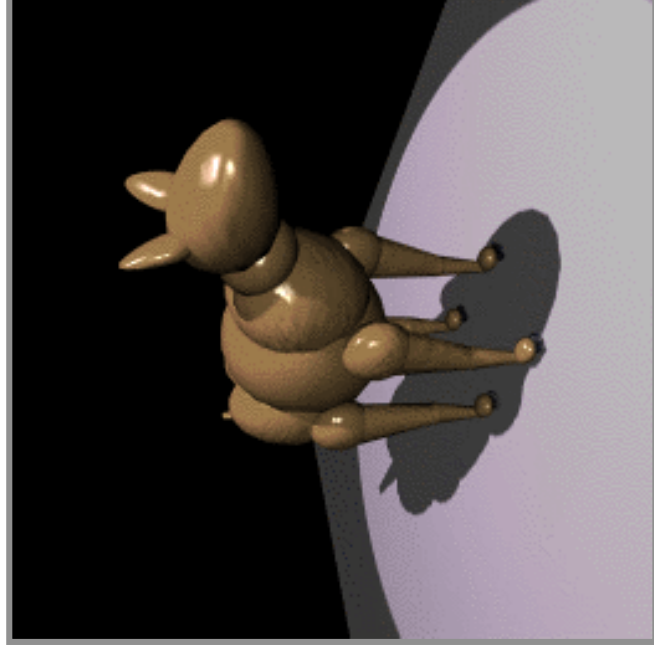

avalon.viewpoint.com

Others?

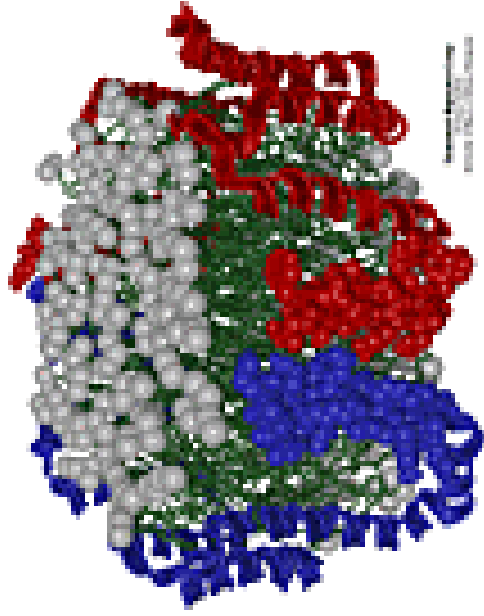
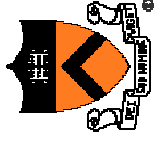

Apo A-1
*(Theoretical Biophysics Group,
University of Illinois at Urbana-Champaign)*

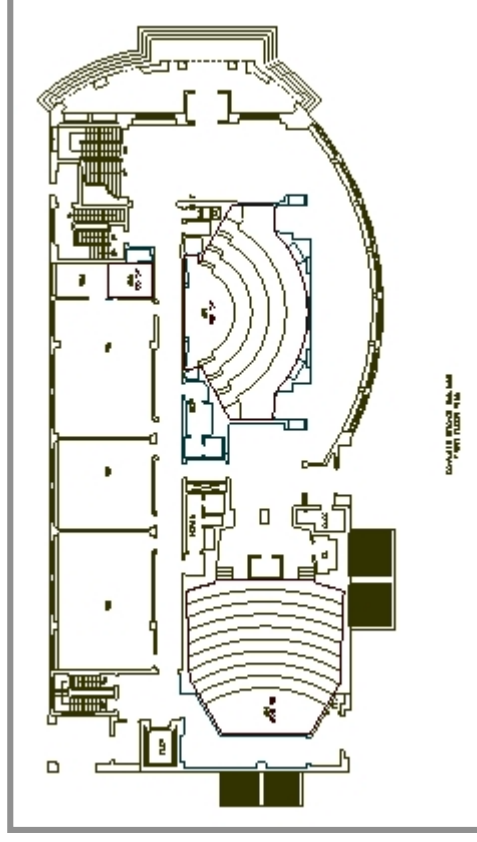

Architectural Floorplan
(CS Building, Princeton University)

Summary

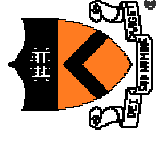

- Goals
 - Reconstruction
 - Segmentation
 - Feature detection
 - Labeling
 - Matching
 - Classification
 - Retrieval
 - Recognition
 - Clustering

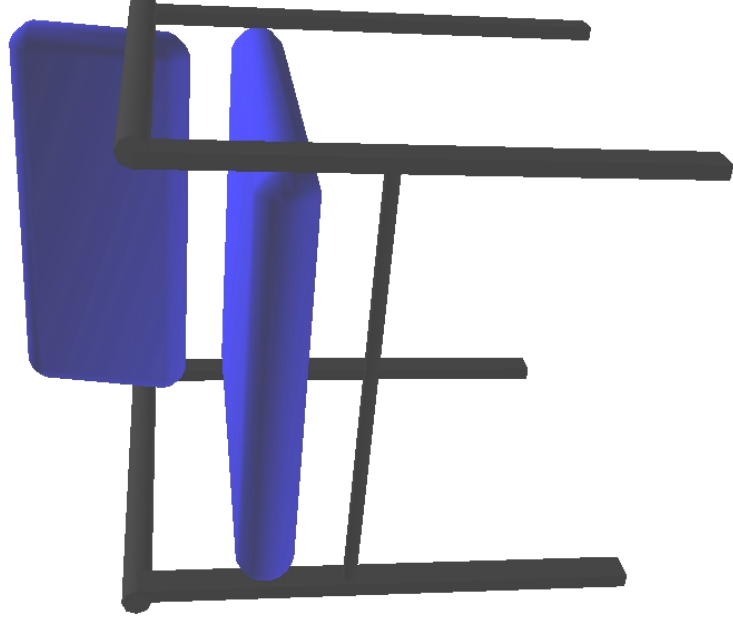

Summary

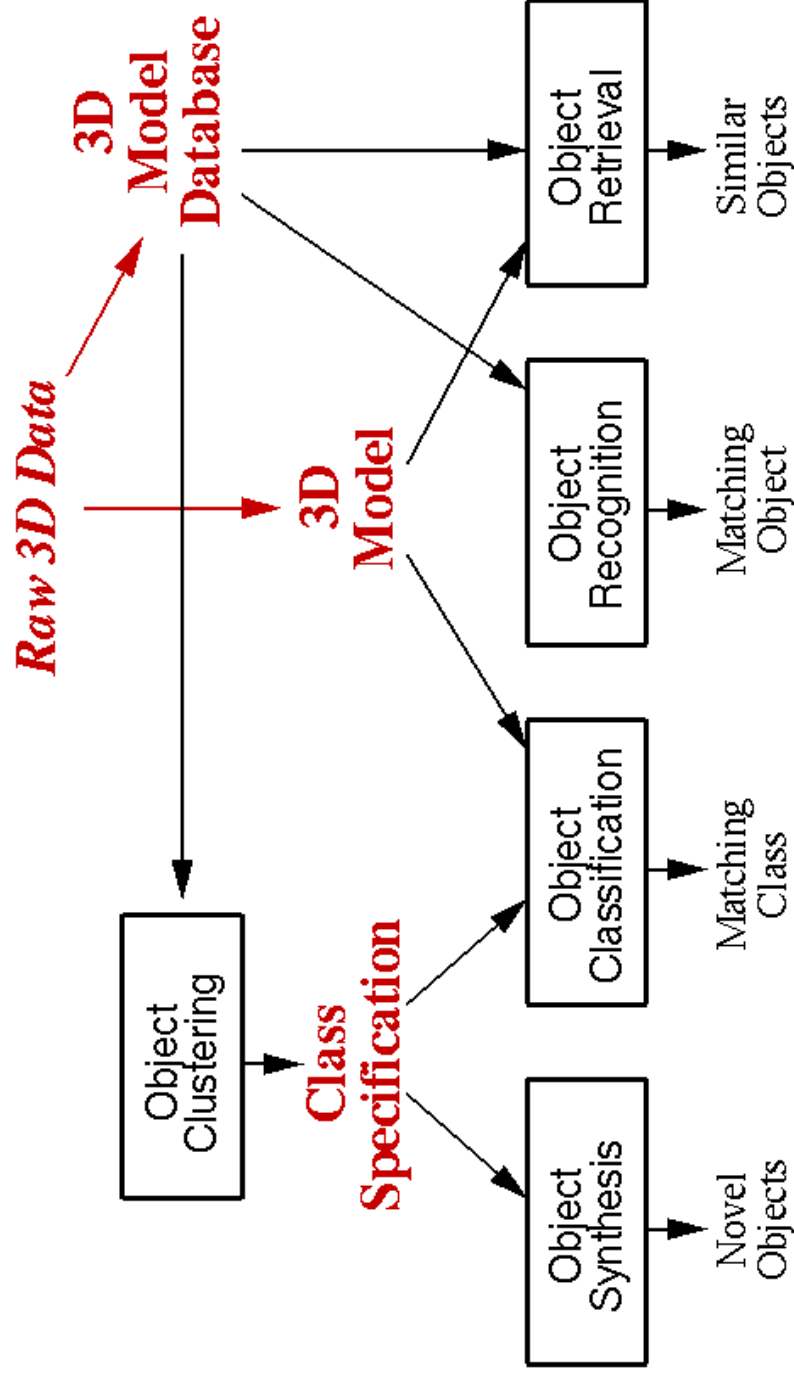
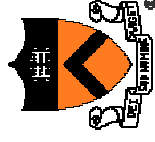

3D object representation is key!

Summary

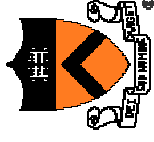

- Raw data
 - Point cloud
 - Range image
 - Polygon soup
- Solids
 - Voxels
 - BSP tree
 - Cell complex
- Surfaces
 - Mesh
 - Subdivision
 - Parametric
 - Implicit
- High-level structures
 - CSG
 - Constrained blocks
 - Generative model
 - Skeleton
 - Sweep
 - Scene graph