



COS 318: Operating Systems

CPU Scheduling

(<http://www.cs.princeton.edu/courses/cos318/>)



Today's Topics

- ◆ CPU scheduling basics
- ◆ CPU Scheduling algorithms



When to Schedule?

- ◆ Process/thread creation
- ◆ Process/thread exit
- ◆ Blocking on I/O or synchronization
- ◆ I/O interrupt
- ◆ Clock interrupt (pre-emptive scheduling)



Preemptive vs. Non-Preemptive Scheduling

◆ Preemptive scheduling

- Running \Rightarrow ready
- Blocked \Rightarrow ready
- Running \Rightarrow blocked
- Terminate

◆ Non-preemptive scheduling

- Running \Rightarrow blocked
- Terminate

◆ Batch vs interactive vs real-time

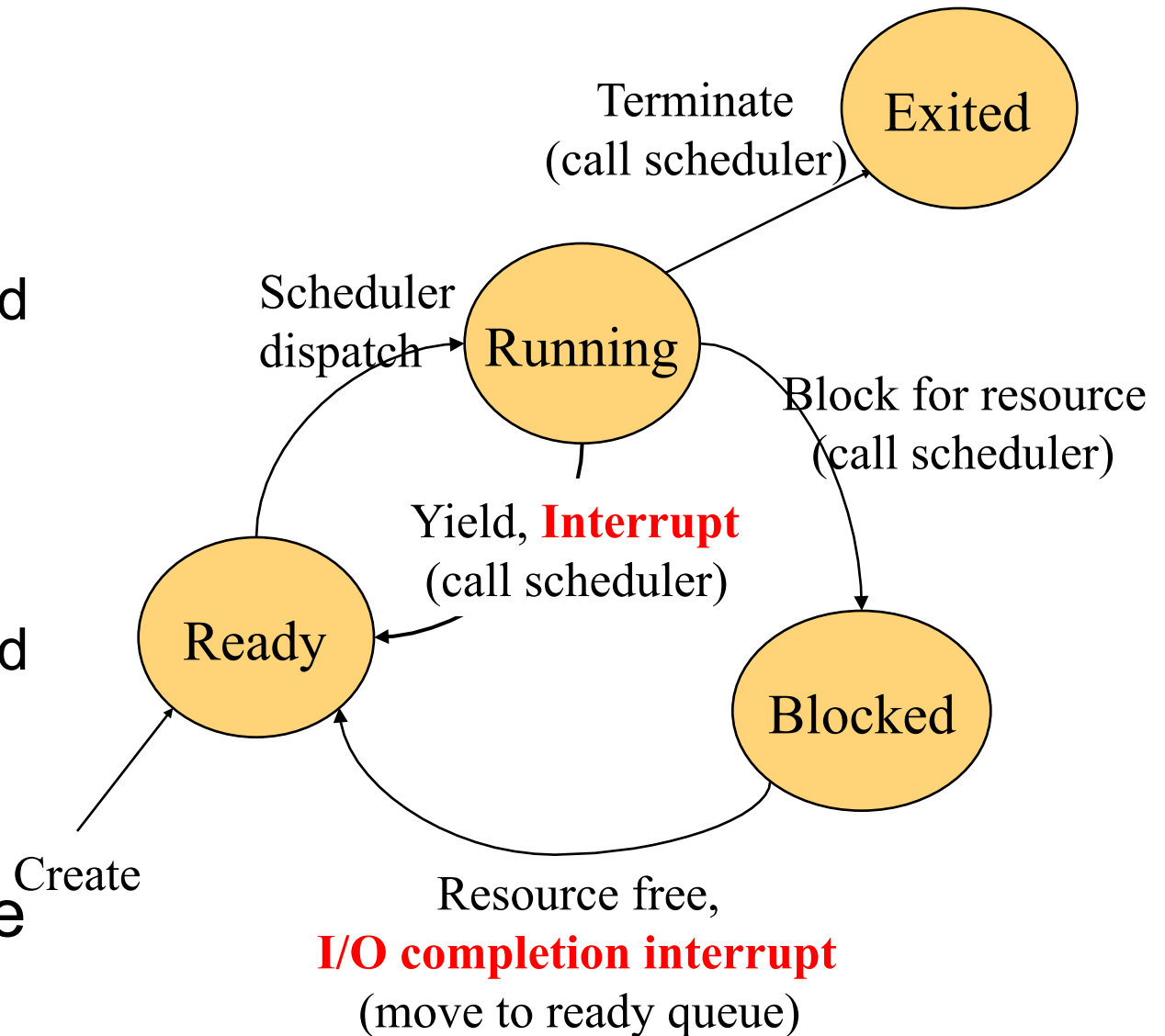

Scheduling Criteria

◆ Assumptions

- One program per user and one thread per program
- Programs are independent

◆ Goals for batch and interactive systems

- Provide fairness
- Everyone makes some progress; no one starves
- Maximize CPU utilization
 - Not including idle process
- Maximize throughput
 - Operations/second (min overhead, max resource utilization)
- Minimize turnaround time
 - Batch jobs: time to execute (from submission to completion)
- Shorten response time
 - Interactive jobs: time response (e.g. typing on a keyboard)
- Proportionality
 - Meets user's expectations



Scheduling Criteria

- ◆ Questions:
 - What are the goals for PCs versus servers?
 - Average response time vs. throughput
 - Average response time vs. fairness



Problem Cases

- ◆ Completely blind about job types
 - No CPU and I/O overlap.
- ◆ Optimization involves favoring jobs of type “A” over “B”
 - Lots of A’s? B’s starve.
- ◆ Interactive process trapped behind others
 - Response time bad for no good reason.
- ◆ Priorities: A depends on B and A’s priority $>$ B’s
 - B never runs.



Scheduling Algorithms

- ◆ Simplified view of scheduling:
 - Save process state (to PCB)
 - **Pick which process to run next**
 - Dispatch process



First-Come-First-Serve (FCFS) Policy

◆ What does it mean?

- Run to completion (old days)
- Run until blocked or yields

◆ Example 1

- P1 = 24sec, P2 = 3sec, and P3 = 3sec, submitted together
- Average response time = $(24 + 27 + 30) / 3 = 27$



◆ Example 2

- Same jobs but come in different order: P2, P3 and P1
- Average response time = $(3 + 6 + 30) / 3 = 13$



(Gantt Graph)



STCF and SRTCF

- ◆ Shortest Time to Completion First
 - Non-preemptive
- ◆ Shortest Remaining Time to Completion First
 - Preemptive version
- ◆ Example
 - P1 = 6sec, P2 = 8sec, P3 = 7sec, P4 = 3sec
 - All arrive at the same time



- ◆ Can you do better than SRTCF in terms of average response time?
- ◆ Issues with this approach?



Round Robin

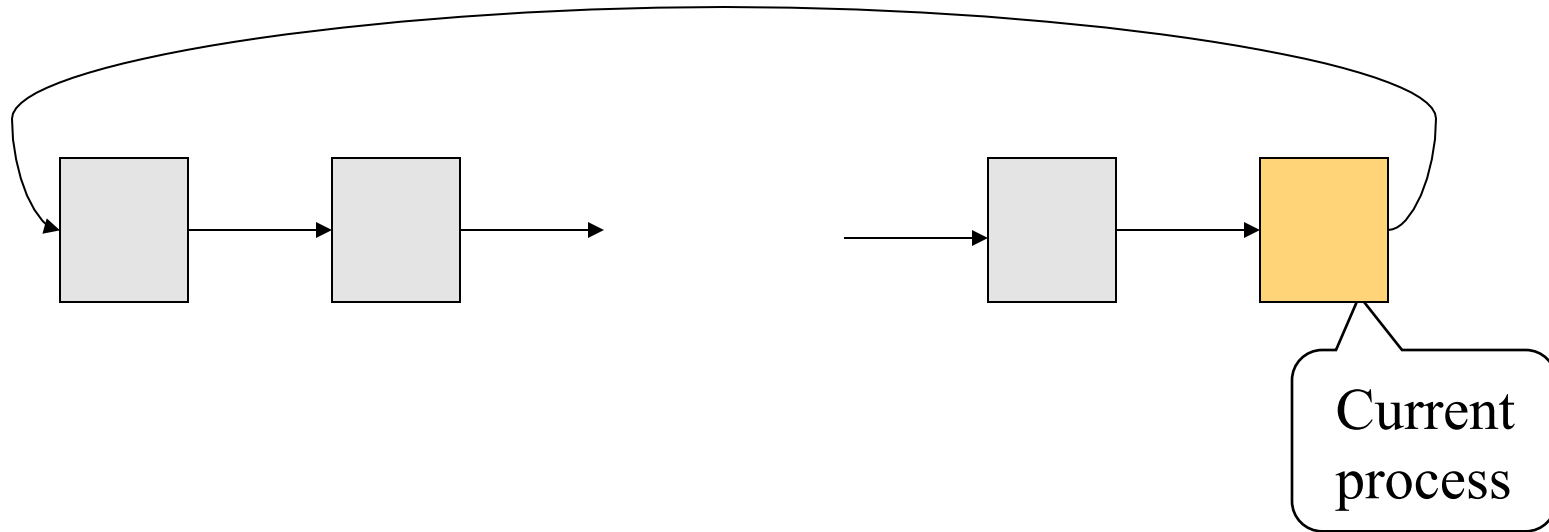

- ◆ Similar to FCFS, but add a time slice for timer interrupt
- ◆ FCFS for preemptive scheduling
- ◆ Real systems also have I/O interrupts in the mix
- ◆ How do you choose time slice?



FCFS vs. Round Robin

◆ Example

- 10 jobs and each takes 100 seconds

◆ FCFS (non-preemptive scheduling)

- job 1: 100s, job2: 200s, ... , job10: 1000s

◆ Round Robin (preemptive scheduling)

- time slice 1sec and no overhead
- job1: 991s, job2: 992s, ... , job10: 1000s

◆ Comparisons

- Round robin is much worse (turnaround time) for jobs about the same length
- Round robin is better for short jobs



Resource Utilization Example

- ◆ A, B, and C run forever (in this order)
 - A and B each uses 100% CPU forever
 - C is a CPU plus I/O job (1ms CPU + 10ms disk I/O)
- ◆ Time slice 100ms
 - A (100ms CPU), B (100ms CPU), C (1ms CPU + 10ms I/O),
...
- ◆ Time slice 1ms
 - A (1ms CPU), B (1ms CPU), C (1ms CPU),
A (1ms CPU), B (1ms CPU), C(10ms I/O) || A, B, ..., A, B
- ◆ What do we learn from this example?



Virtual Round Robin

- ◆ Aux queue is FIFO
- ◆ I/O bound processes go to aux queue (instead of ready queue) to get scheduled
- ◆ Aux queue has preference over ready queue

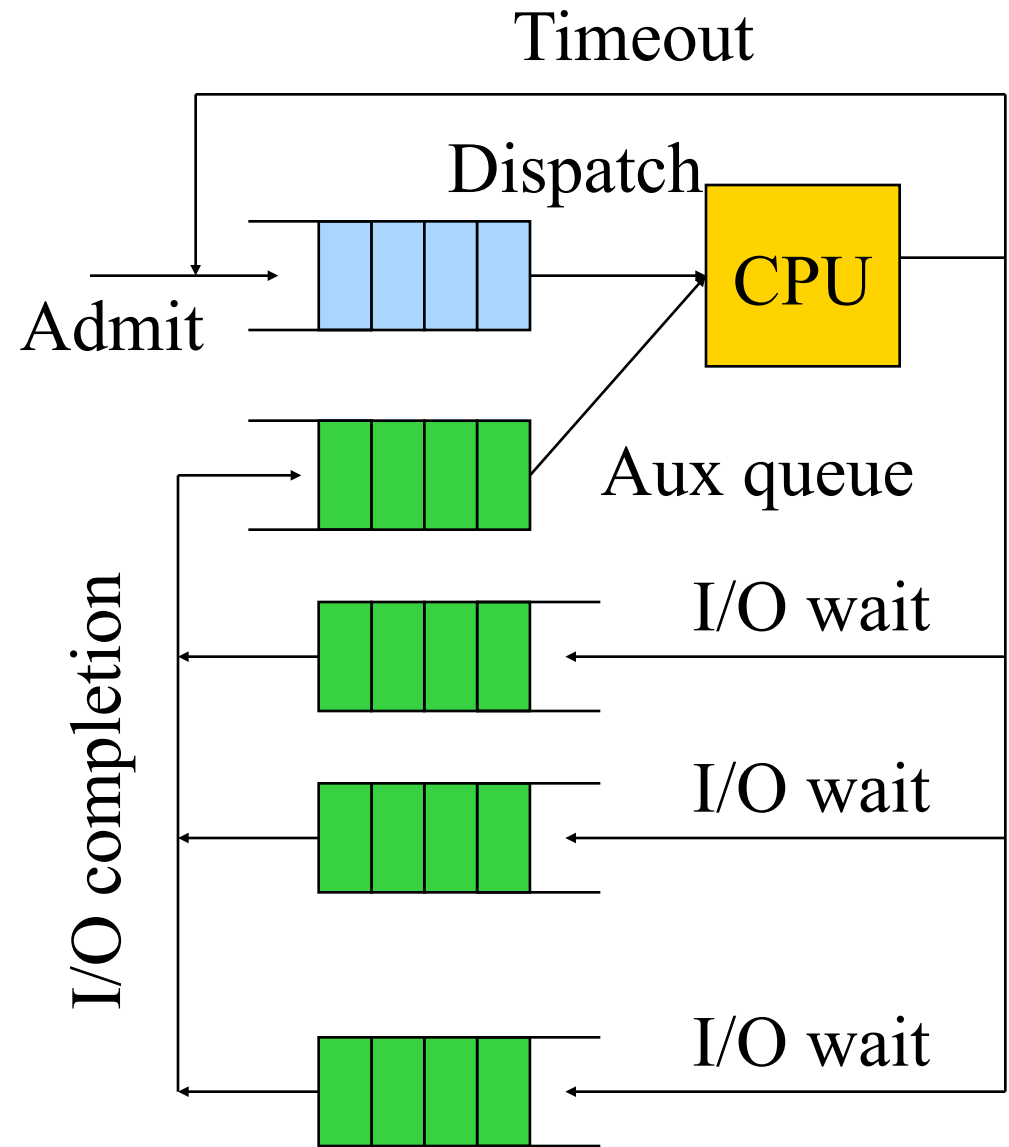

Priority Scheduling

◆ Obvious

- Not all processes are equal, so rank them

◆ The method

- Assign each process a priority
- Run the process with highest priority in the ready queue first
- Adjust priority dynamically (I/O wait raises the priority, reduce priority as process runs)

◆ Why adjusting priorities dynamically

- T1 at priority 4, T2 at priority 1 and T2 holds lock L
- Scenario
 - T1 tries to acquire L, fails, blocks.
 - T3 enters system at priority 3.
 - T2 never gets to run!



Multiple Queues

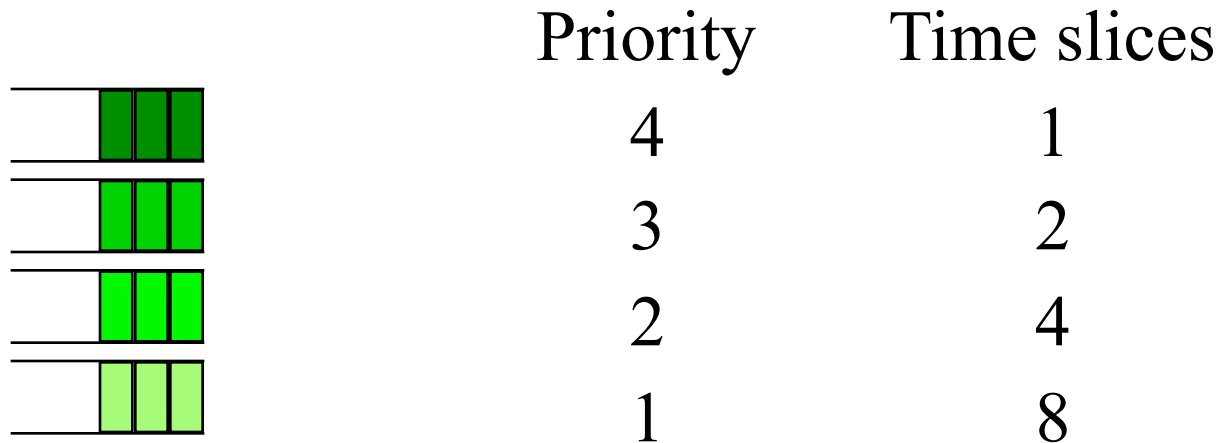

- ◆ Jobs start at highest priority queue
- ◆ If timeout expires, drop one level
- ◆ If timeout doesn't expires, stay or pushup one level

- ◆ What does this method do?



Lottery Scheduling

◆ Motivations

- SRTCF does well with average response time, but unfair

◆ Lottery method

- Give each job a number of tickets
- Randomly pick a winning tickets
- To approximate SRTCF, give short jobs more tickets
- To avoid starvation, give each job at least one ticket
- Cooperative processes can exchange tickets

◆ Question

- How do you compare this method with priority scheduling?



Multiprocessor and Cluster

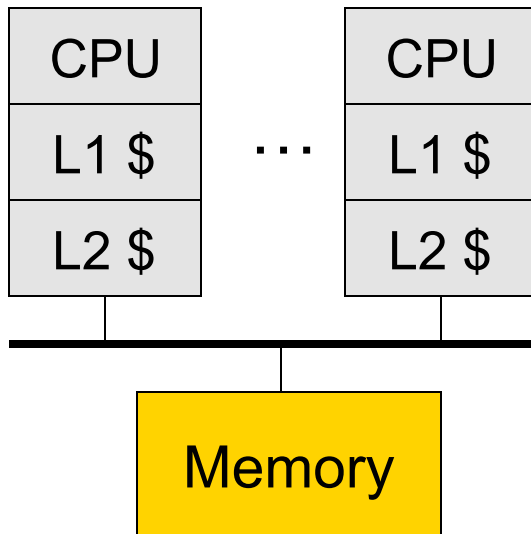

Multiprocessor architecture

- ◆ Cache coherence
- ◆ Single OS

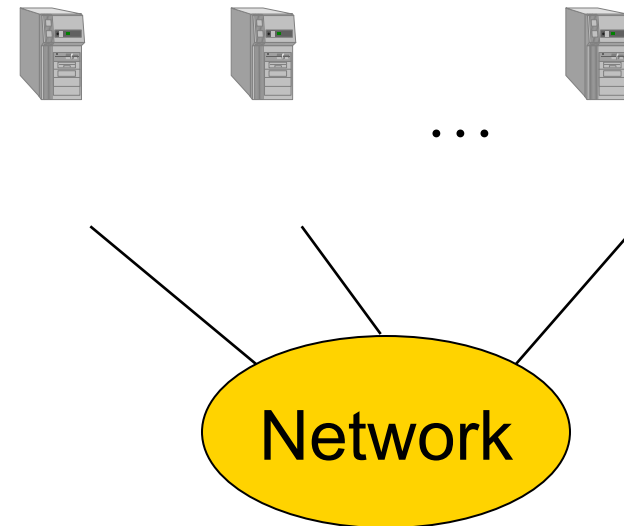

Cluster or multicomputer

- ◆ Distributed memory
- ◆ An OS in each box

Multiprocessor/Cluster Scheduling

- ◆ Design issue
 - Process/thread to processor assignment
- ◆ Gang scheduling (co-scheduling)
 - Threads of the same process will run together
 - Processes of the same application run together
- ◆ Dedicated processor assignment
 - Threads will be running on specific processors to completion
 - Is this a good idea?



Real-Time Scheduling

◆ Two types of real-time

- Hard deadline
 - Must meet, otherwise can cause fatal error
- Soft Deadline
 - Meet most of the time, but not mandatory

◆ Admission control

- Take a real-time process only if the system can guarantee the “real-time” behavior of all processes
- The jobs are schedulable, if the following holds:

$$\sum \frac{C_i}{T_i} \leq 1$$

where C_i = computation time, and T_i = period



Rate Monotonic Scheduling (Liu & Layland 73)

◆ Assumptions

- Each periodic process must complete within its period
- No process is dependent on any other process
- Each process needs the same amount of CPU time on each burst
- Non-periodic processes have no deadlines
- Process preemption occurs instantaneously (no overhead)

◆ Main ideas of RMS

- Assign each process a fixed priority = frequency of occurrence
- Run the process with highest priority
- Prove to be optimal

◆ Example

- P1 runs every 30ms gets priority 33 (33 times/sec)
- P2 runs every 50ms gets priority 20 (20 times/sec)



Earliest Deadline Scheduling

◆ Assumptions

- When a process needs CPU time, it announces its deadline
- No need to be periodic process
- CPU time needed may vary

◆ Main idea of EDS

- Sort ready processes by their deadlines
- Run the first process on the list (earliest deadline first)
- When a new process is ready, it preempts the current one if its deadline is closer

◆ Example

- P1 needs to finish by 30sec, P2 by 40sec and P3 by 50sec
- P1 goes first
- More in MOS 7.4.4



4.3 BSD Scheduling with Multi-Queue

- ◆ “1 sec” preemption
 - Preempt if a process doesn't block or complete within 1 second
- ◆ Priority is recomputed every second
 - $P_i = \text{base} + (\text{CPU}_{i-1}) / 2 + \text{nice}$, where $\text{CPU}_i = (U_i + \text{CPU}_{i-1}) / 2$
 - Base is the base priority of the process
 - U_i is process utilization in interval i
- ◆ Priorities
 - Swapper
 - Block I/O device control
 - File operations
 - Character I/O device control
 - User processes



Linux Scheduling

◆ Time-sharing scheduling

- Each process has a priority and # of credits
- I/O event will raise the priority
- Process with the most credits will run next
- A timer interrupt causes a process to lose a credit
- If no process has credits, then the kernel issues credits to all processes: $\text{credits} = \text{credits}/2 + \text{priority}$

◆ Real-time scheduling

- Soft real-time
- Kernel cannot be preempted by user code



Windows Scheduling

- ◆ Classes and priorities
 - Real time: 16 static priorities
 - Variable: 16 variable priorities, start at a base priority
 - If a process has used up its quantum, lower its priority
 - If a process waits for an I/O event, raise its priority
- ◆ Priority-driven scheduler
 - For real-time class, do round robin within each priority
 - For variable class, do multiple queue
- ◆ Multiprocessor scheduling
 - For N processors, run N-1 highest priority threads on N-1 processors and run remaining threads on a single processor
 - A thread will wait for processors in its affinity set, if there are other threads available (for variable priorities)



Summary

- ◆ Different scheduling goals
 - Depend on what systems you build
- ◆ Scheduling algorithms
 - Small time slice is important for improving I/O utilization
 - STCF and SRTCF give the minimal average response time
 - Priority and its variations are in most systems
 - Lottery is flexible
 - Real-time depends on admission control

