

CS 436 HCI Technology

Basic Electricity/Electronics Review

*Copyright 1997-2008,
Perry R. Cook, Princeton University

August 27, 2008

1 Basic Quantities and Units

1.1 Charge

Number of electrons or units of electron charge

Units: Coulombs (C) = $6.242 \cdot 10^{18}$ electrons worth of charge

1.2 Voltage

Potential energy per unit charge

Common Symbol: V

Units: Volts (V) = Joules / Coulomb

1.3 Current

Flow rate of charge

Common Symbol: I

Units: Amperes (or Amps, A) = Coulombs / second

1.4 Power

Energy flow (same as in basic Newtonian mechanics)

Common Symbol: P

Units: Watts (W) = Joules / second

$P = VI$

Power = Voltage across element * Current through element

1.5 Resistance

Converts current into heat

Common Symbol: Ω (the Ohm)

Ohm's Law: $V = IR$ or $I = V/R$

this means $Power = VI = V^2/R = I^2R$

2 Useful Circuit Analysis Tools and Laws

2.1 Power Sources

Ideal Sources: Deliver rated voltage or current regardless of load

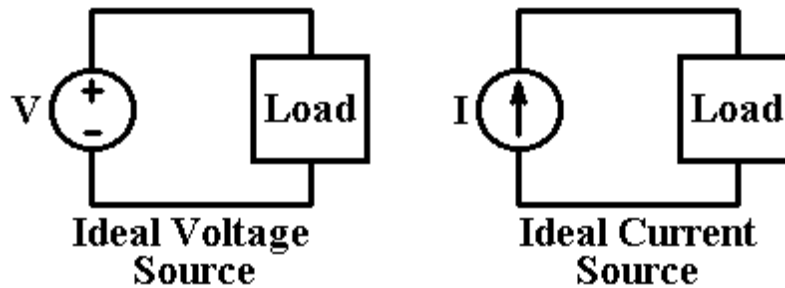

Practical Sources: All sources have some internal resistance

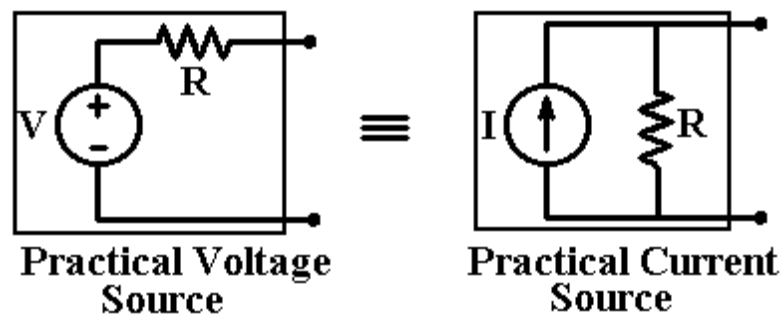

3 Kirchoff's Laws

Voltage Law:

$$\sum V_{loop} = 0 \quad \text{Conservative Potential Energy Field}$$

Current Law:

$$\sum I_{node} = 0 \quad \text{Conservation of Matter (charge)}$$

Voltage Example:

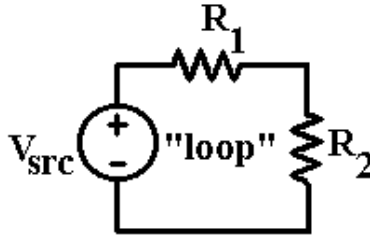

$$V_{src} - IR_1 - IR_2 = 0 \quad (\text{currents must all be same})$$

$$I(R_1 + R_2) = V_{src} \quad (\text{Ohm's Law})$$

So Resistors Add in Series

$$V_{R1} = IR_1 \quad V_{R2} = IR_2$$

$$I = \frac{V_{src}}{R_1 + R_2}$$

$$\text{thus} \quad V_{R2} = \frac{V_{src}R_2}{R_1 + R_2}$$

This is called "Voltage Division."

Voltage Division gives rise to a very popular analog interface sensor and device: The Potentiometer (or "Pot")

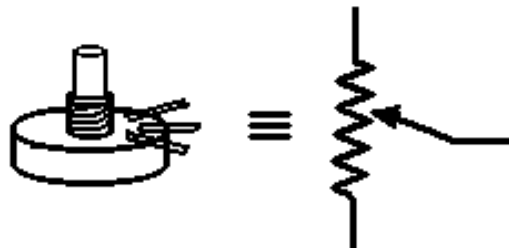

Pots are nice because they're cheap, and relatively low-noise (but see below). Pots are not so nice because there's scraping involved with use, and they can wear out. Also cheap ones can get dirty or wet and stop working pretty quickly.

Pot-related voltage division circuits:

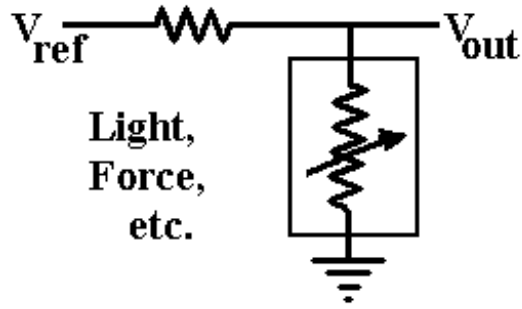

Current Example:

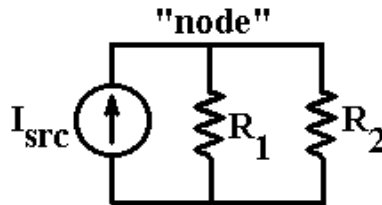

$$I_{src} - I_{R1} - I_{R2} = 0 \text{ (sum of currents must = 0)}$$

$$I_{src} - V/R_1 - V/R_2 = 0$$

$$I_{src} = \frac{V}{\frac{1}{R_1} + \frac{1}{R_2}} \text{ or}$$

$$V = I_{src} \frac{R_1 R_2}{R_1 + R_2} \text{ (Ohm's Law)}$$

Define Conductance = $G = 1/R$ (inverse of Resistance)

$$\text{so} \quad G_1 = 1/R_1 \quad \text{and} \quad G_2 = 1/R_2$$

$$G_1 + G_2 = \frac{R_1 + R_2}{R_1 R_2} = \frac{1}{R_1} + \frac{1}{R_2}$$

meaning Conductances Add In Parallel, or currents divide across parallel conductances This is the DUAL of Resistances, which add in series, with voltage dividing across series resistors.

A Combination Loop (Voltage) and Node (Current) Problem:

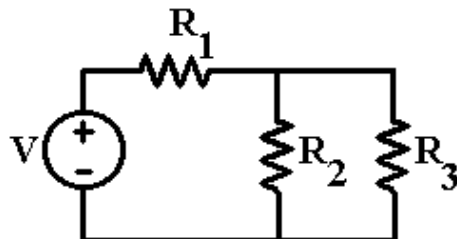

What's $V_{R2} = V_{R3}$?

$$V - V_{R1} - V_{R2(or R3)} = 0$$

$$V_{R2} = \frac{V \frac{R_2 R_3}{R_2 + R_3}}{R_1 + \frac{R_2 R_3}{R_2 + R_3}}$$

$$V_{R2} = V \frac{R_2 R_3}{R_1 R_2 + R_1 R_3 + R_2 R_3}$$

4 Some More Circuit Elements

4.1 Capacitors (and Capacitance)

Units: Farads (F, after Michael Faraday)



Voltage between plates is a function of charge difference between plates. Energy is stored in an electric (potential) field. Constant current causes linearly rising (or falling) charge difference, and thus a steady linearly changing voltage.

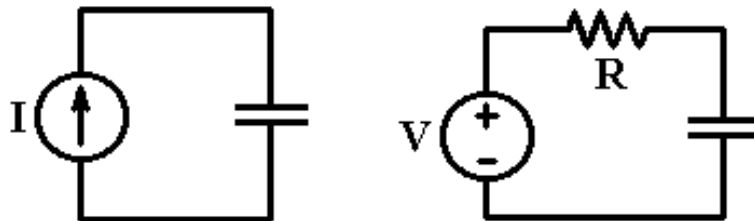

$$v_c = \frac{1}{C} \int_0^t I(\tau) d\tau$$

$$= \frac{1}{C} I t \text{ (for initial voltage} = 0 \text{ and constant current } I)$$

$$i_C = C \frac{dv_C(t)}{dt}$$

$$\text{if } V_C(0) = 0, \text{ then } V_R(0) = -V_{src}$$

$$V_C(\infty) = -V_{src} \text{ and } V_R(\infty) = 0$$

$$V_C(t) = (1 - e^{-\frac{t}{RC}})V_{src}$$

$$V_R(t) = V_{src}e^{-\frac{t}{RC}}$$

1/RC is often called the "R C Time Constant"

Capacitance is proportional to:

$$\frac{\text{Area of Plates}}{\text{Distance between Plates}}$$

Sometimes the human body/ground is used as one plate, and thus proximity of you (or your hand) can be inferred by determining the capacitance between you and a metal plate.

Capacitors exhibit a form of complex resistance (1/conductance) called Impedance (1/admittance), equal to 1/sC, where

$$s = \sigma + j\omega \quad j = \sqrt{-1}$$

Sigma is real, and describes the direct current (DC) behavior. The j omega term is imaginary, and describes the AC behavior.

Since capacitors are just parallel plates, then add linearly when connected in parallel.

4.2 Inductors (and Inductance)

Units: Henries (H, after Princeton's Own Joseph Henry)

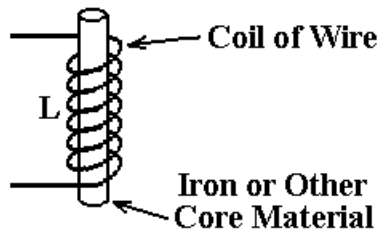

Current in coil causes magnetic field, which stores energy.

$$\text{Impedance of Inductor} = sL = (\sigma + j\omega)L$$

$$v_L(t) = L \frac{di_L}{dt}$$

or

$$i_L(t) = \frac{1}{L} \int_0^t v_L \tau d\tau$$

Inductors add in series (it's just a longer coil of wire)

If all elements, including resistors, capacitors, and inductors are treated as complex resistances, with the appropriate impedance values substituted in the basic circuit analysis equations (Kirchoff's and Ohm's Laws), everything "works out in the algebra." You can just write things out in the calculus form, again applying Ohm's and Kirchoff's laws.

5 An Important Example Circuit

Let's look at a special circuit just using the fundamental laws and relations of Ohm's Law, Kirchoff's Voltage and Current Laws, and the calculus descriptions of the inductor and the capacitor.



Initial values: $i_L(0) = 0$, zero initial current in inductor

$v_C(0) = V$, some initial charge on Capacitor

We could use the fact that all voltages must be equal.

$$v_R(t) = i_R(t)R \text{ (Ohm's Law)}$$

$$= v_L(t) = L \frac{di_L(t)}{dt}$$

$$= v_C(t) = \frac{1}{C} \int_0^t i_C(\tau) d\tau$$

But circuit topology dictates a nodal equation (sum of currents = 0), so we use the current law:

$$\frac{v(t)}{R} + \frac{1}{L} \int_0^t v(\tau) d\tau + C \frac{dv(t)}{dt} = 0$$

differentiate once:

$$C \frac{d^2v(t)}{dt^2} + \frac{1}{R} \frac{dv(t)}{dt} + \frac{1}{L} v(t) = 0$$

$$\frac{d^2v(t)}{dt^2} + \frac{1}{RC} \frac{dv(t)}{dt} + \frac{1}{LC} v(t) = 0$$

But Hold It!! That's the same form as our mass, spring, and damper system from the Introductory Physics Lecture!

So we know the answer. For example, the underdamped solution is:

$$v(t) = Ve^{-\alpha t} \cos(\omega_d t)$$

$\alpha = \frac{1}{2RC}$ "Neper Frequency" exponential damping,
Units: 1/seconds

$\omega_d = \sqrt{\omega_0^2 - \alpha^2}$ the damped oscillation frequency
Units: radians/second

where $\omega_0 = \frac{1}{\sqrt{LC}}$ the undamped oscillation frequency
Units: radians/second

6 Solid State Circuit Elements

6.1 Diodes

allow current to flow in only one direction (a non-linear element)

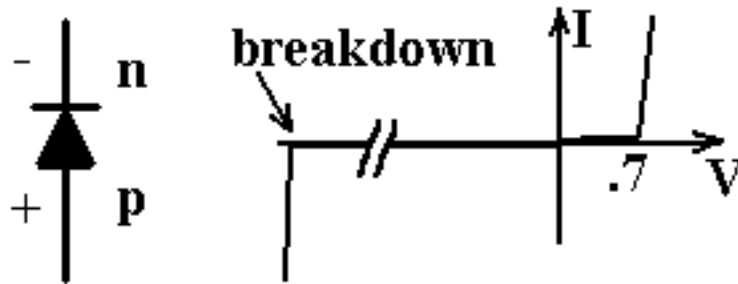

Voltage across a diode is ≈ 0.7 volts, Forward Bias
 $V_{applied}$, Reverse Bias

6.2 Transistors

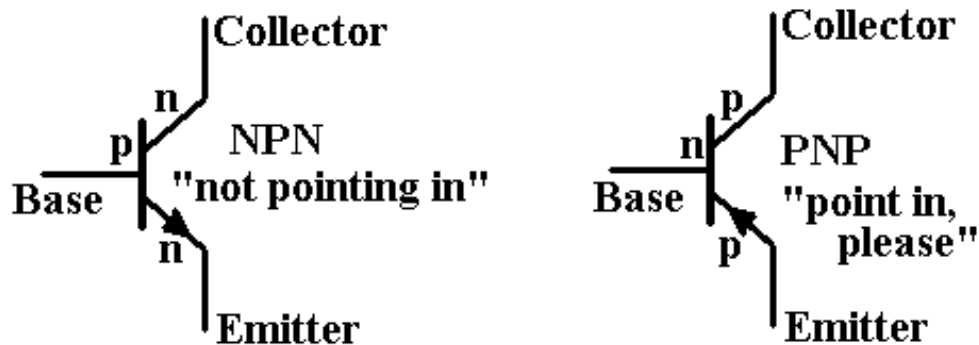

Basic NPN Transistor Inverting Switch

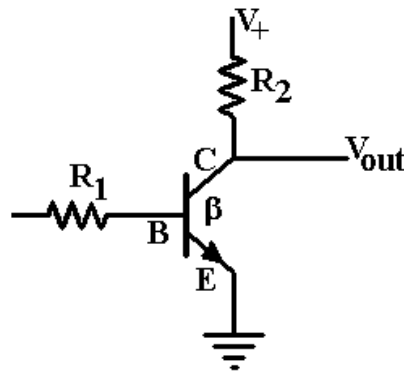

Beta is "Current Gain." If Base-Emitter pn junction is forward biased, current flows through the Collector-Emitter junction with a maximum gain of Beta.

No load on V_{out} :

1) If $V_{in} = 0$ $V_{out} = V^+$

2) If $V_{in} > 0.7\text{volts}$ $I_{R2} = \text{the smaller of}$
 βI_{R1} or $\frac{V^+}{R_2}$

so $V_{out} \approx 0$ volts

Note: Add R_{1b} connected to base, and another input v_{inb} , and we get a NOR Gate. From DeMorgan's Theorem, NORs plus Inverters yield NANDs, and thus we can do all combitorial logic using only circuits like the above.

7 Operational Amplifiers (Op Amps)

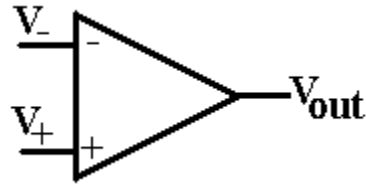

7.1 Basic Ideal Op Amp Analysis

Op amp analysis is based on three idealized assumptions:

- 1) $v_- = v_+$
- 2) $i_- = i_+ = 0$ no current flows into op amp ($R_{in} = \infty$)
- 3) output pin is ideal source (can supply any voltage at infinite current)

7.2 Example: The Non-Inverting Buffer

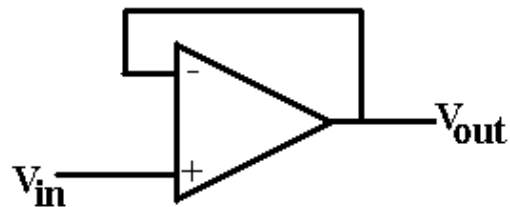

$$v_{out} = v_{in} \quad R_{in} = \infty. \quad \text{Output has } \infty \text{ source capability}$$

7.3 Another Example: The Inverting Amplifier

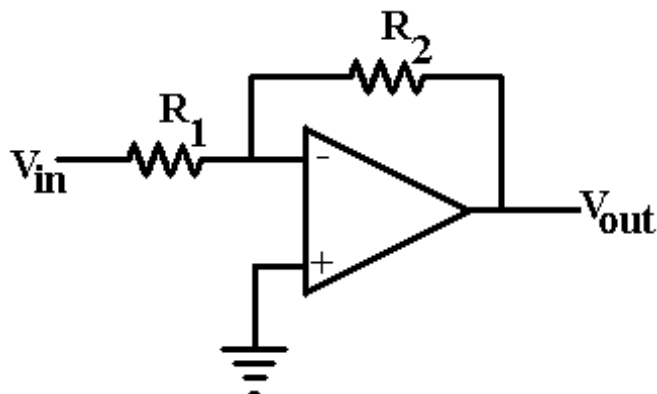

$$i_{R_1} = -i_{R_2}$$

$$v_{out} = i_{R_2} R_2$$

$$v_{in} = i_{R_1} R_1$$

$$v_{out}/R_2 = -v_{in}/R_1$$

$$v_{out} = -v_{in} \frac{R_2}{R_1} \quad \frac{R_2}{R_1} \text{ is Gain}$$

$$\text{Input impedance} = R_1$$

7.4 Another Example: The Non-Inverting Amplifier

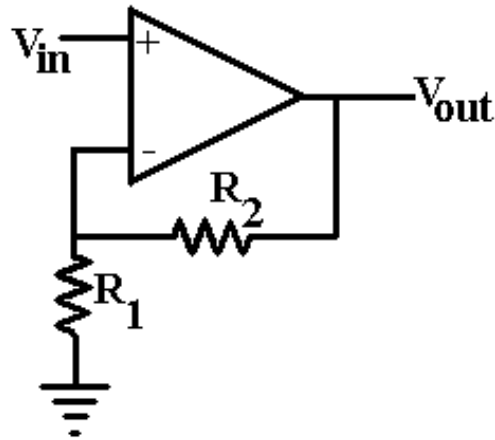

$$v_+ = v_- = v_{in}$$

$$i_{R_1} = i_{R_2} = \frac{v_-}{R_1} = \frac{v_+}{R_1} = \frac{v_{in}}{R_1}$$

$$v_{out} = v_{in} + \frac{v_{in}}{R_1} R_2$$

$$v_{out} = v_{in} \frac{R_1 + R_2}{R_1}$$

$$\text{Input impedance} = \infty$$

Gain must be greater than or equal to 1.0

7.5 Final Op Amp Thoughts

Placing a component in the feedback path can dualize its behavior: C goes to L, L goes to C, etc.

Practical Op Amps cannot exactly obey ideal rules, especially with low impedance loads, high gains, and increasing frequency input signals.

Op amps are cheap, and get better and cheaper every day.

8 References: Beginning Electronics

Two good introductory (hacker) electronics books:

How to Read Schematics, Herrington, 4th Edition

IC Op-Amp Cookbook, Walter G. Jung

both available on Sams Publications

9 copyright

* Permission to make digital or hard copies of part or all of this work for personal or classroom use is granted with or without fee provided that copies are not made or distributed for profit or commercial advantage and that copies bear this notice and full citation on the first page. To copy otherwise, to republish, to post on services, or to redistribute to lists, requires specific permission and/or a fee.