



Solid Modeling

Thomas Funkhouser
Princeton University
COS 426, Fall 2000



Solid Modeling

- Represent solid interiors of objects
 - Surface may not be described explicitly



Visible Human
(National Library of Medicine)

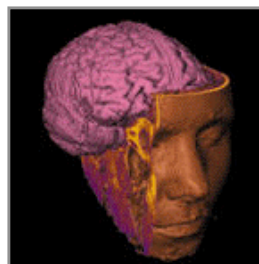

SUNY Stoney Brook

Motivation 1



- Some acquisition methods generate solids
 - Example: CAT scan



Stanford University

Motivation 2



- Some applications require solids
 - Example: CAD/CAM

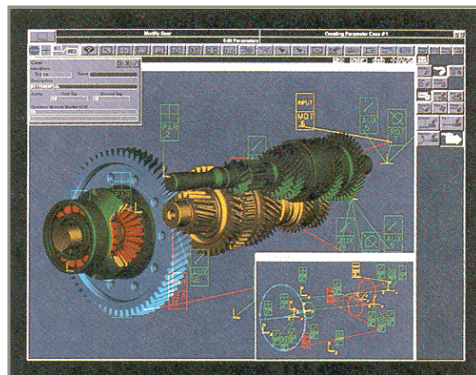

Intergraph Corporation

Motivation 3



- Some algorithms require solids
 - Example: ray tracing with refraction

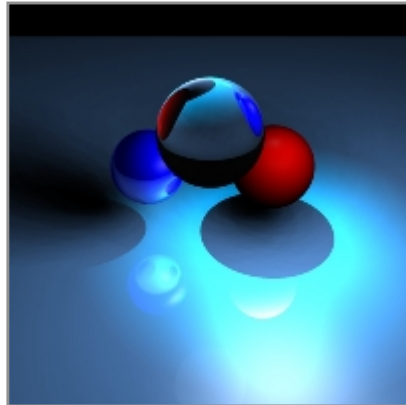

Addy Ngan and Zaijin Guan
COS 426, 1998
Princeton University

Solid Modeling Representations



- Voxels
- Quadtrees & Octrees
- Binary space partitions
- Constructive solid geometry

Solid Modeling Representations



- What makes a good solid representation?
 - Accurate
 - Concise
 - Affine invariant
 - Easy acquisition
 - Guaranteed validity
 - Efficient boolean operations
 - Efficient display

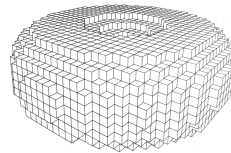

Voxels

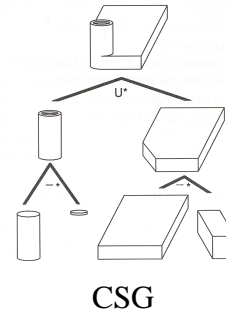

FvDFH

Solid Modeling Representations



- Voxels
- Quadtrees & Octrees
- Binary space partitions
- Constructive solid geometry

Voxels



- Partition space into uniform grid
 - Grid cells are called a *voxels* (like pixels)
- Store properties of solid object with each voxel
 - Occupancy
 - Color
 - Density
 - Temperature
 - etc.

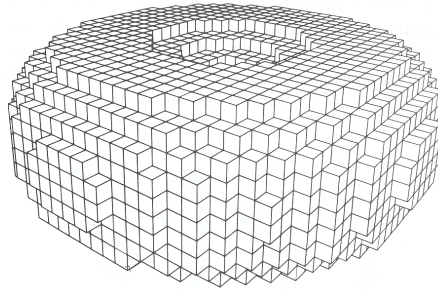

FvDFH Figure 12.20

Voxel Acquisition



- Scanning devices
 - MRI
 - CAT
- Simulation
 - FEM



SUNY Stony Brook

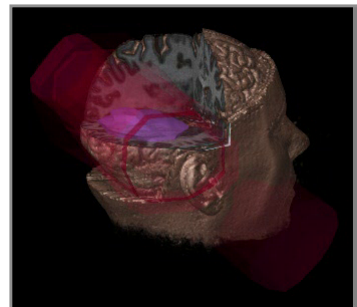

Stanford University

Voxel Storage



- $O(n^3)$ storage for $n \times n \times n$ grid
 - 1 billion voxels for $1000 \times 1000 \times 1000$

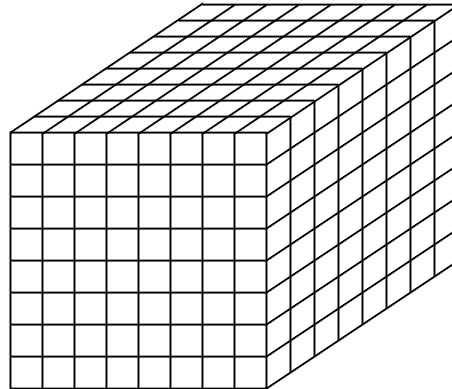

Voxel Boolean Operations



- Compare objects voxel by voxel
 - Trivial

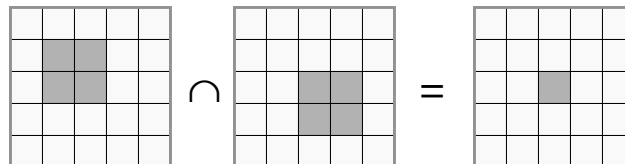
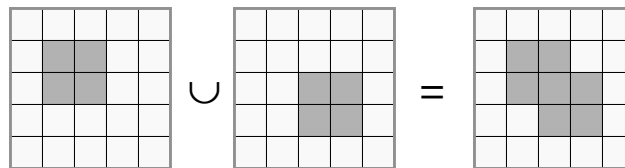

Voxel Display



- Isosurface rendering
 - Render surfaces bounding volumetric regions of constant value (e.g., density)

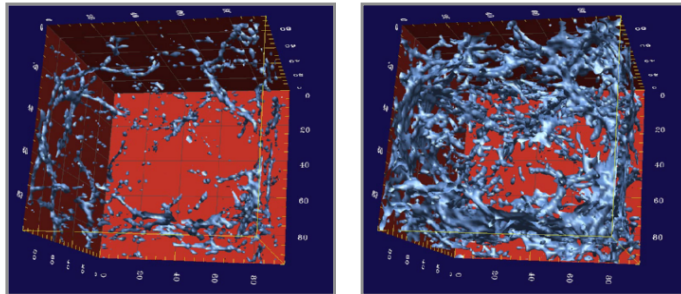

Isosurface Visualization
Princeton University

Voxel Display



- Slicing
 - Draw 2D image resulting from intersecting voxels with a plane

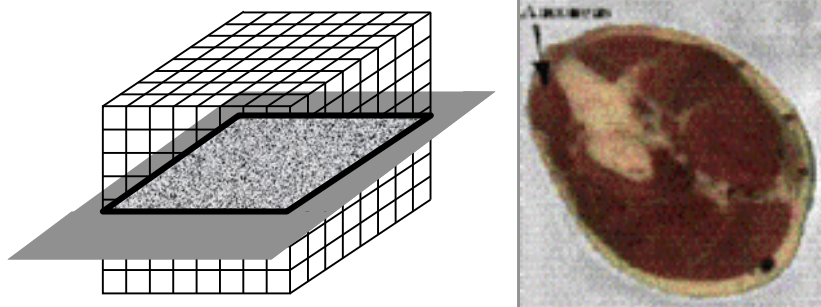

Visible Human
(National Library of Medicine)

Voxel Display



- Ray casting
 - Integrate density along rays through pixels

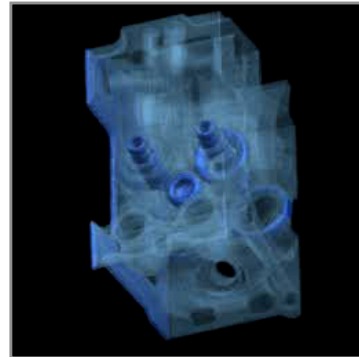
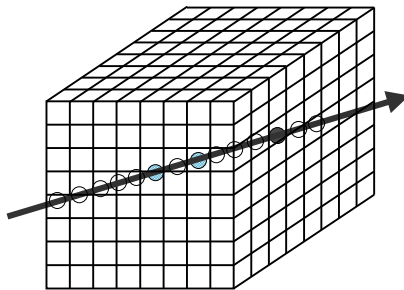

Engine Block
Stanford University

Voxels



- Advantages
 - Simple, intuitive, unambiguous
 - Same complexity for all objects
 - Natural acquisition for some applications
 - Trivial boolean operations
- Disadvantages
 - Approximate
 - Not affine invariant
 - Large storage requirements
 - Expensive display

Solid Modeling Representations



- Voxels
- Quadtrees & Octrees
- Binary space partitions
- Constructive solid geometry

Quadtrees & Octrees



- Refine resolution of voxels hierarchically
 - More concise and efficient for non-uniform objects

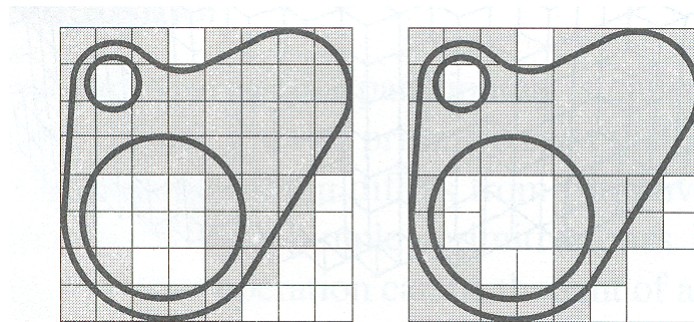

Uniform Voxels

Quadtree

FvDFH Figure 12.21

Quadtree Boolean Operations

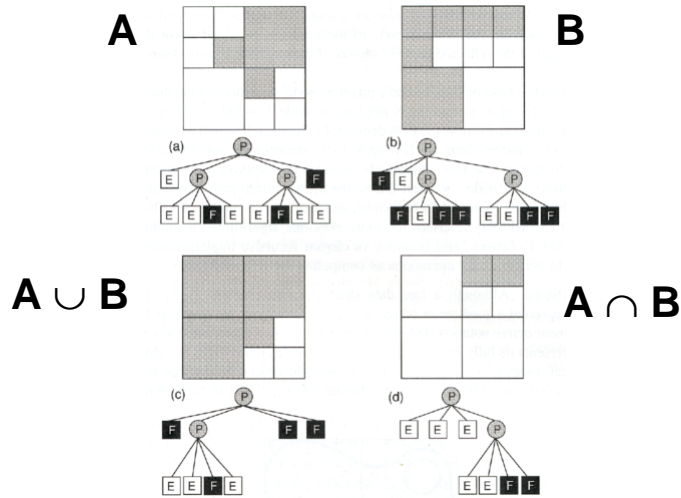

FvDFH Figure 12.24

Quadtree Display



- Extend voxel methods
 - Slicing
 - Isosurface extraction
 - Ray casting

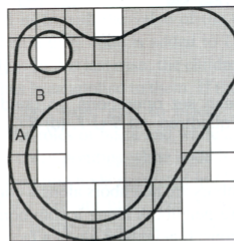

Finding neighbor cell requires traversal of hierarchy ($O(1)$)

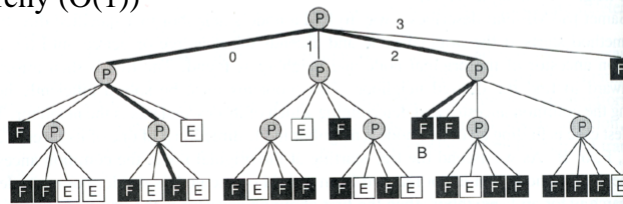

FvDFH Figure 12.25

Solid Modeling Representations



- Voxels
- Quadtrees & Octrees
- Binary space partitions
- Constructive solid geometry

Binary Space Partitions (BSPs)



- Recursive partition of space by planes
 - Mark leaf cells as inside or outside object

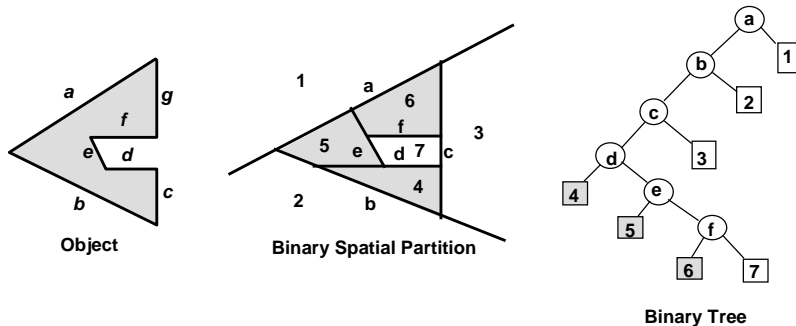

Naylor

BSP Fundamentals



- Single geometric operation
 - Partition a convex region by a hyperplane
- Single combinatorial operation
 - Two child nodes added as leaf nodes

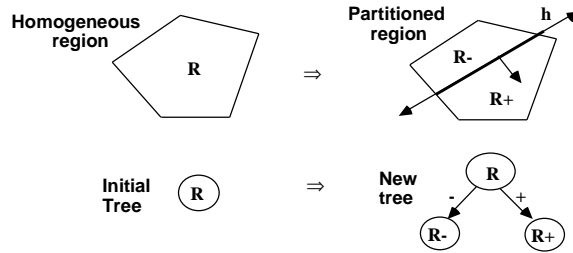

Naylor

BSP is a Search Structure



- Exploit hierarchy of convex regions
 - Regions decrease in size along any tree path
 - Regions converge in the limit to the surface

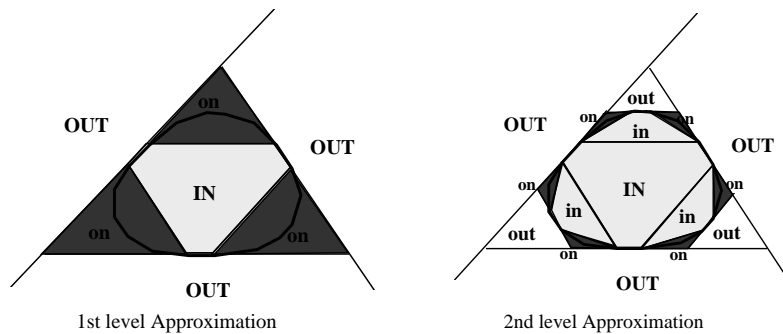

Naylor

BSP Acquisition



- Must construct a “good” binary search structure
 - Efficiency comes from logarithmic tree depth

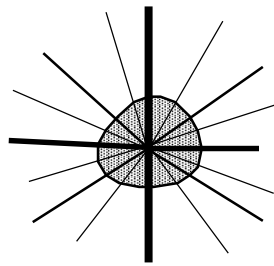

“Bad”

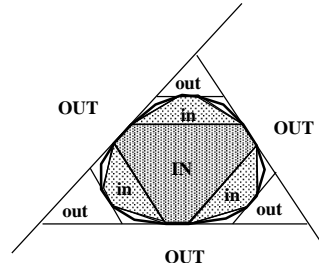

“Good”

Naylor

BSP Boolean Operations



- Divide and conquer
 - Each node V corresponds to a convex region *containing* all geometry in the subtree rooted at V
 - No intersection with bounding volume of V means no intersection with subtree rooted at V
 - Do detail work only in regions required
 - Boolean operations grow with $O(\log n)$ if “good” tree

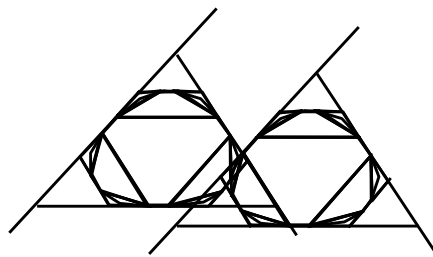

Naylor

BSP Display



- Visibility ordering
 - Determine on which side of plane the viewer lies
 - » near-subtree -> polygons on split -> far-subtree

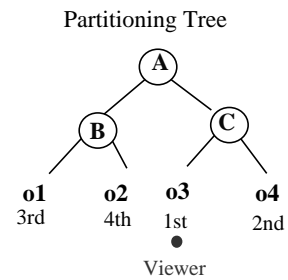
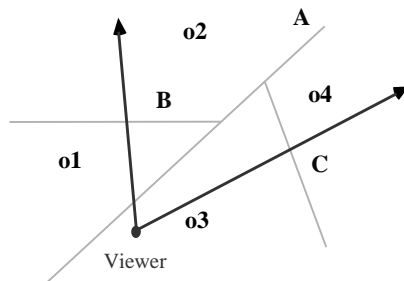

Naylor

Solid Modeling Representations



- Voxels
- Quadrees & Octrees
- Binary space partitions
- Constructive solid geometry

Constructive Solid Geometry (CSG)

- Represent solid object as hierarchy of boolean operations
 - Union
 - Intersection
 - Difference

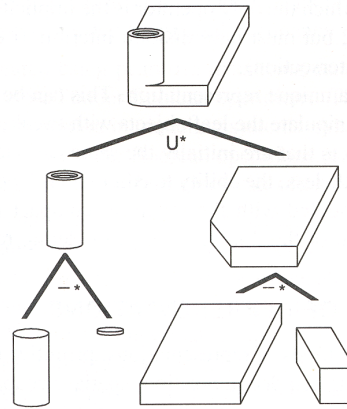

FvDFH Figure 12.27

CSG Acquisition

- Interactive modeling programs
 - CAD/CAM

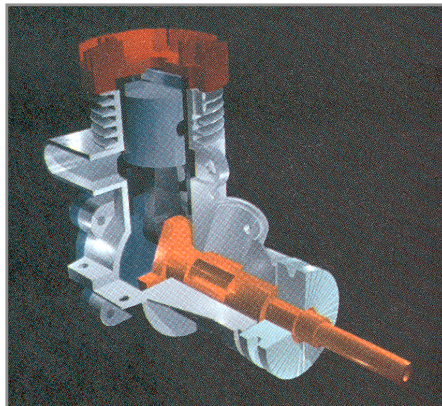

H&B Figure 9.9

CSG Boolean Operations



- Create a new CSG node joining subtrees
 - Union
 - Intersection
 - Difference

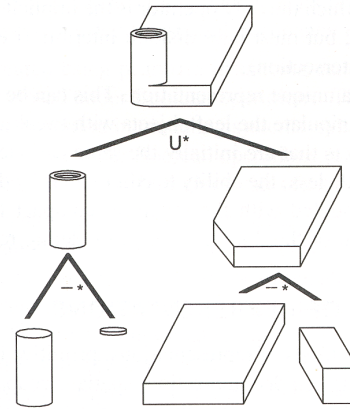

FvDFH Figure 12.27

CSG Display & Analysis



- Ray casting

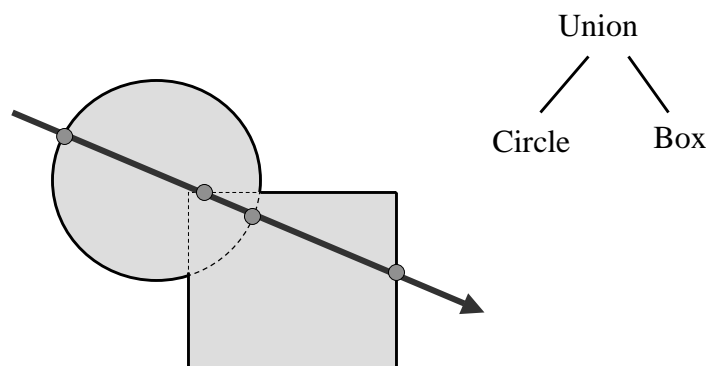

Summary



	Voxels	Octree	BSP	CSG
Accurate	No	No	Some	Some
Concise	No	No	No	Yes
Affine invariant	No	No	Yes	Yes
Easy acquisition	Some	Some	No	Some
Guaranteed validity	Yes	Yes	Yes	No
Efficient boolean operations	Yes	Yes	Yes	Yes
Efficient display	No	No	Yes	No