



Overview of 3D Object Representations

Thomas Funkhouser
Princeton University
COS 426, Fall 2000



Course Syllabus

I. Image processing

II. Rendering

III. Modeling

IV. Animation

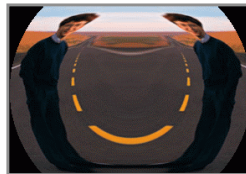
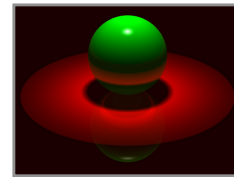
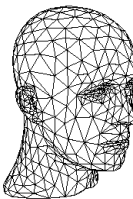

Image Processing
(Rusty Coleman, CS426, Fall99)



Rendering
(Michael Bostock, CS426, Fall99)



Modeling
(Dennis Zorin, CalTech)

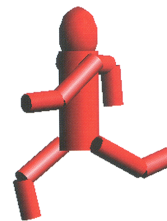

Animation
(Angel, Plate 1)

Course Syllabus



I. Image processing

II. Rendering

III. Modeling

IV. Animation

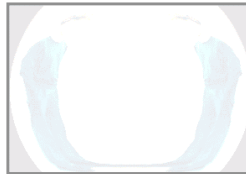
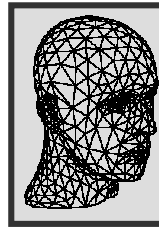

Image Processing
(Rusty Coleman, CS426, Fall99)



Rendering
(Michael Bostock, CS426, Fall99)



Modeling
(Dennis Zorin, CalTech)

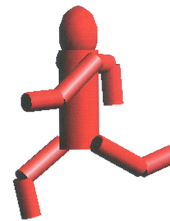

Animation
(Angel, Plate 1)

Modeling



- How do we ...
 - Represent 3D objects in a computer?
 - Construct such representations quickly and/or automatically with a computer?
 - Manipulate 3D objects with a computer?

Different methods for different object representations

3D Objects

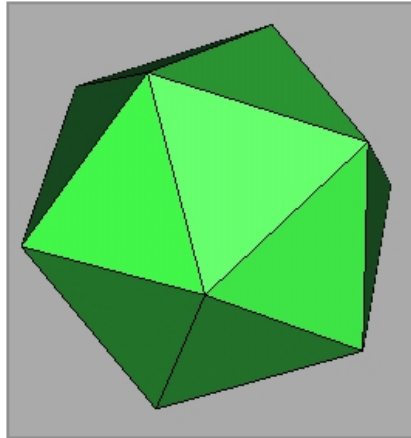

How can this object be represented in a computer?

3D Objects

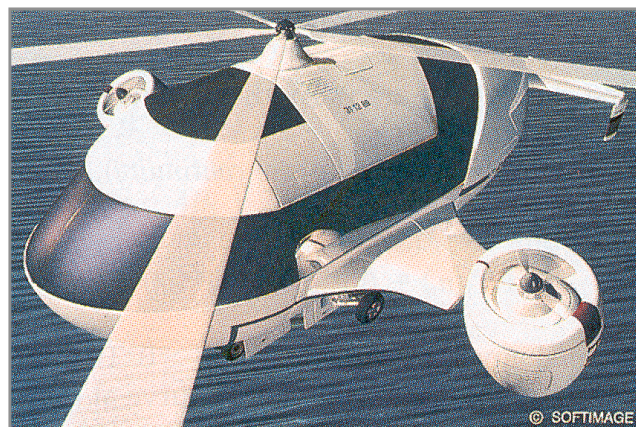

© SOFTIMAGE

H&B Figure 10.46

This one?

3D Objects

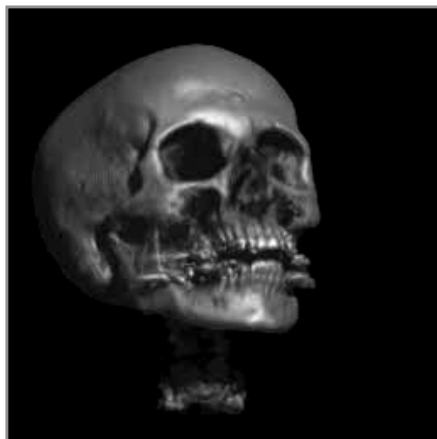

Stanford Graphics Laboratory

How about this one?

3D Objects

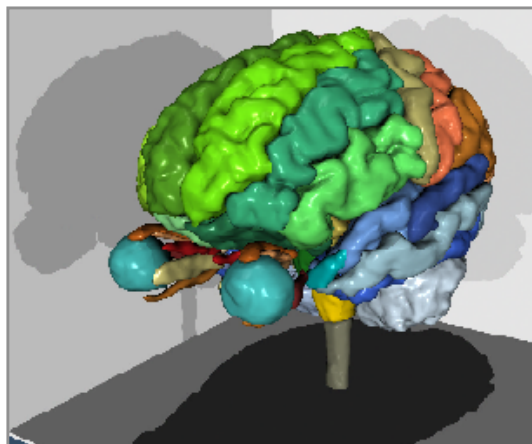

Lorensen

This one?

3D Objects

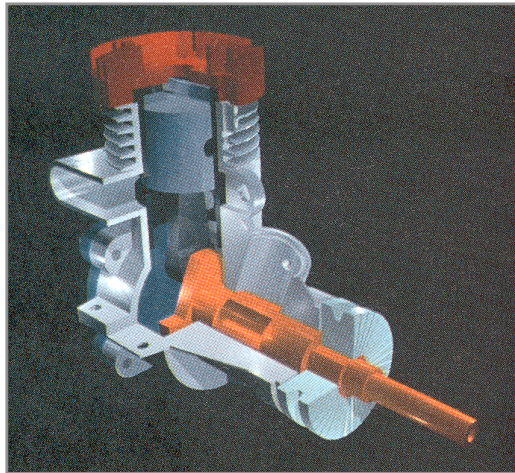

This one?

H&B Figure 9.9

3D Objects

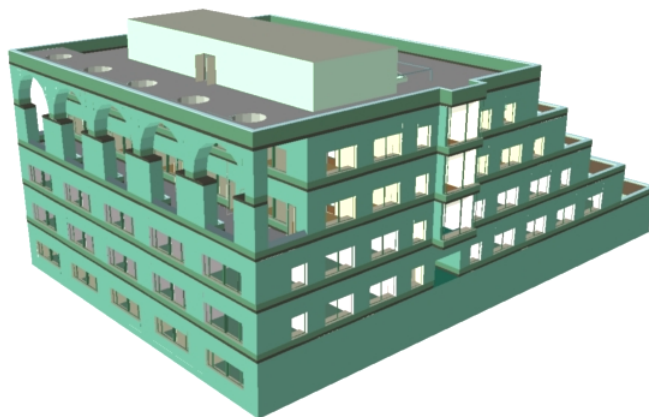

This one?

Representations of Geometry



- 3D Representations provide the foundations for
 - Computer Graphics, Computer-Aided Geometric Design, Visualization, Robotics
- They are languages for describing geometry

<u>Semantics</u>	<u>Syntax</u>
values	<u>data structures</u>
operations	algorithms
- Data structures determine algorithms!

3D Object Representations



- Raw data
 - Point cloud
 - Range image
 - Polygon soup
- Surfaces
 - Mesh
 - Subdivision
 - Parametric
 - Implicit
- Solids
 - Voxels
 - BSP tree
 - CSG
 - Sweep
- High-level structures
 - Scene graph
 - Skeleton
 - Application specific

Point Cloud



- Unstructured set of 3D point samples
 - Acquired from range finder, computer vision, etc

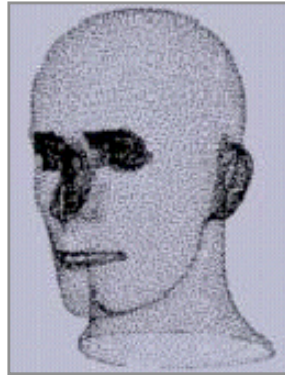

Hoppe



Hoppe

Range Image



- Set of 3D points mapping to pixels of depth image
 - Acquired from range scanner

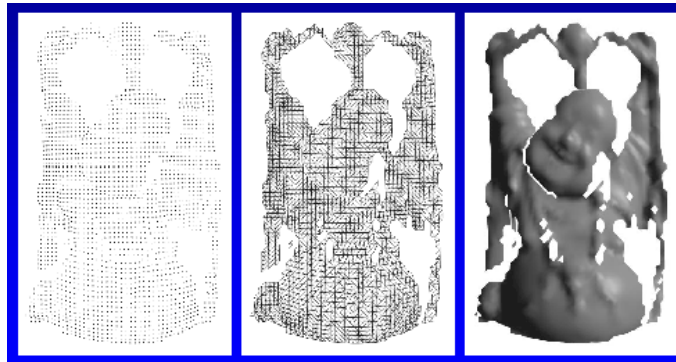

Range Image

Tessellation

Range Surface

Brian Curless
SIGGRAPH 99
Course #4 Notes

Polygon Soup



- Unstructured set of polygons
 - Created with interactive modeling systems?

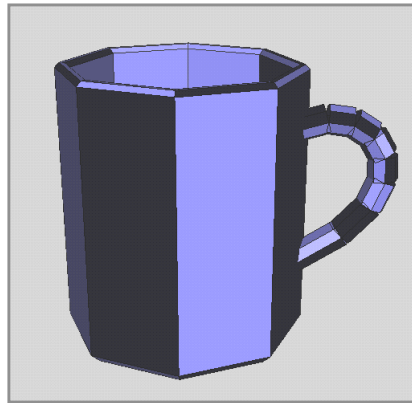

Larson

3D Object Representations



- Raw data
 - Point cloud
 - Range image
 - Polygon soup
- Surfaces
 - Mesh
 - Subdivision
 - Parametric
 - Implicit
- Solids
 - Voxels
 - BSP tree
 - CSG
 - Sweep
- High-level structures
 - Scene graph
 - Skeleton
 - Application specific

Mesh



- Connected set of polygons (usually triangles)
 - May not be closed

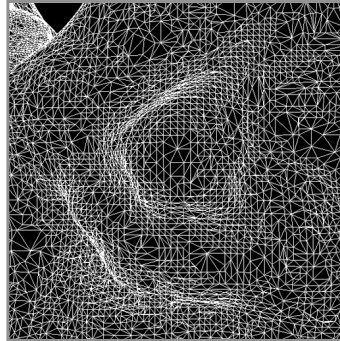

Stanford Graphics Laboratory

Subdivision Surface



- Coarse mesh & subdivision rule
 - Define smooth surface as limit of sequence of refinements

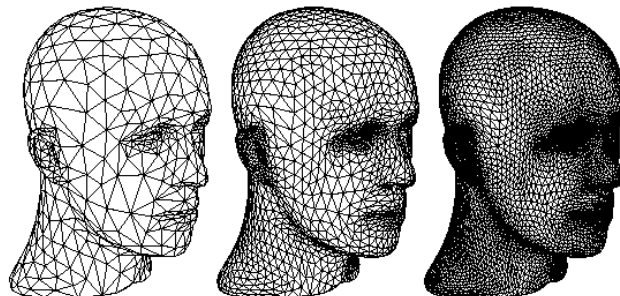

Zorin & Schroeder
SIGGRAPH 99
Course Notes

Parametric Surface



- Tensor product spline patches
 - Careful constraints to maintain continuity

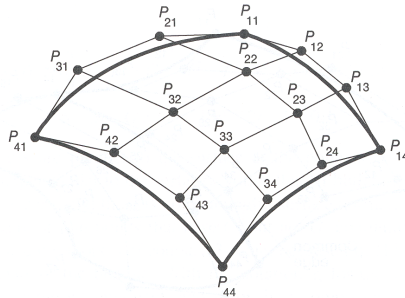

FvDFH Figure 11.44

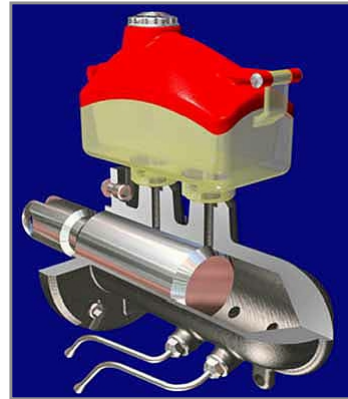

Implicit Surface



- Points satisfying: $F(x,y,z) = 0$

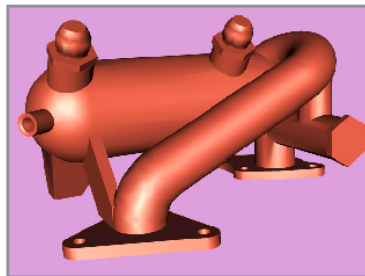

Polygonal Model

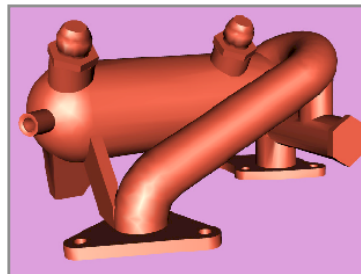

Implicit Model

Bill Lorensen
SIGGRAPH 99
Course #4 Notes

3D Object Representations



- Raw data
 - Point cloud
 - Range image
 - Polygon soup
- Surfaces
 - Mesh
 - Subdivision
 - Parametric
 - Implicit
- Solids
 - Voxels
 - BSP tree
 - CSG
 - Sweep
- High-level structures
 - Scene graph
 - Skeleton
 - Application specific

Voxels



- Uniform grid of volumetric samples
 - Acquired from CAT, MRI, etc.

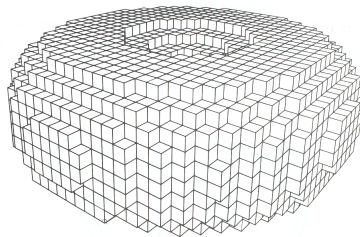

FvDFH Figure 12.20

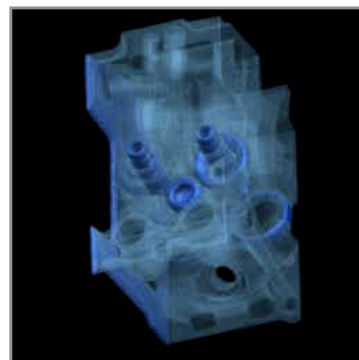

Stanford Graphics Laboratory

BSP Tree



- Binary space partition with solid cells labeled
 - Constructed from polygonal representations

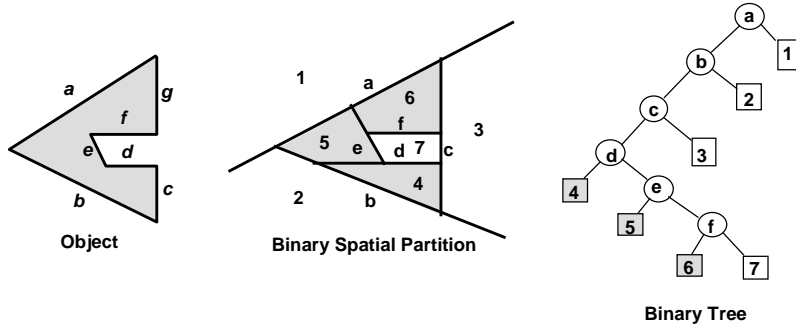

Naylor

CSG



- Hierarchy of boolean set operations (union, difference, intersect) applied to simple shapes

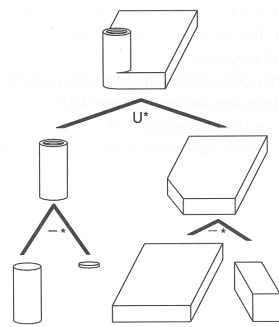

FvDFH Figure 12.27

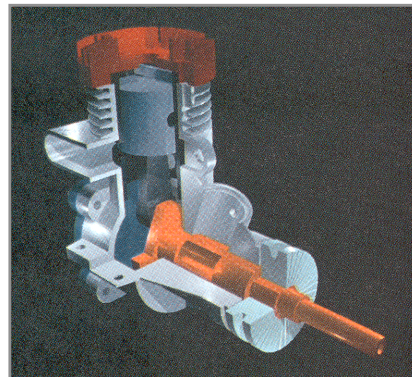

H&B Figure 9.9

Sweep



- Solid swept by curve along trajectory

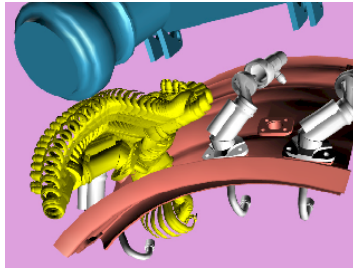

Removal Path

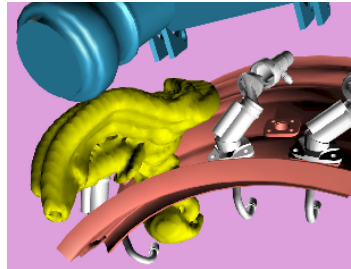

Sweep Model

Bill Lorensen
SIGGRAPH 99
Course #4 Notes

3D Object Representations



- Raw data
 - Point cloud
 - Range image
 - Polygon soup
- Surfaces
 - Mesh
 - Subdivision
 - Parametric
 - Implicit
- Solids
 - Voxels
 - BSP tree
 - CSG
 - Sweep
- High-level structures
 - Scene graph
 - Skeleton
 - Application specific

Scene Graph



- Union of objects at leaf nodes



Bell Laboratories



avalon.viewpoint.com

Skeleton



- Graph of curves with radii

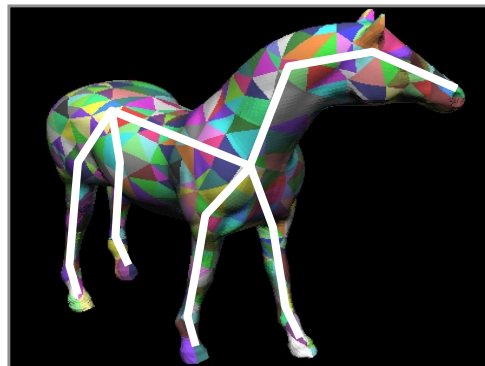

Stanford Graphics Laboratory



SGI

Application Specific

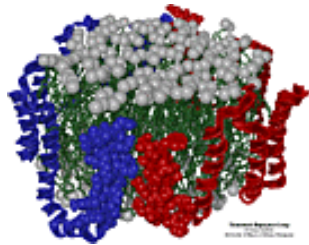

Apo A-1
*(Theoretical Biophysics Group,
University of Illinois at Urbana-Champaign)*

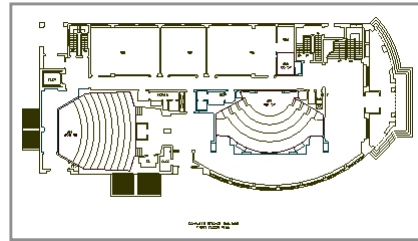

Architectural Floorplan
(CS Building, Princeton University)

Taxonomy of 3D Representations

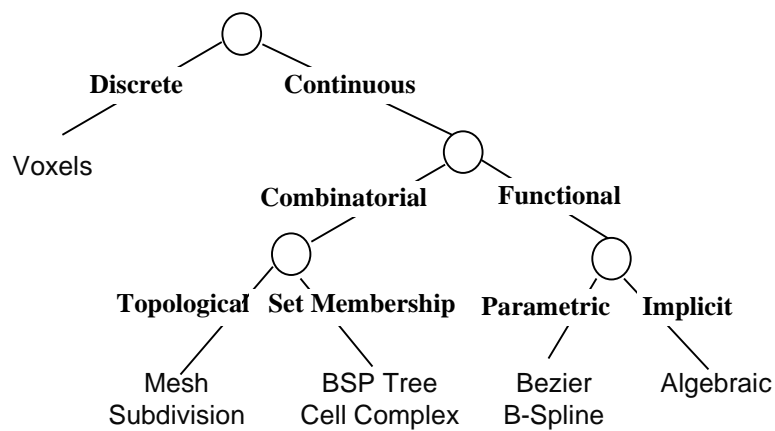

Naylor

Equivalence of Representations



- Thesis:
 - Each fundamental representation has enough expressive power to model the shape of any geometric object
 - It is possible to perform all geometric operations with any fundamental representation!
- Analogous to Turing-Equivalence:
 - All computers today are turing-equivalent, but we still have many different processors

Computational Differences



- Efficiency
 - Combinatorial complexity (e.g. $O(n \log n)$)
 - Space/time trade-offs (e.g. z-buffer)
 - Numerical accuracy/stability (degree of polynomial)
- Simplicity
 - Ease of acquisition
 - Hardware acceleration
 - Software creation and maintenance
- Usability
 - Designer interface vs. computational engine

Complexity vs. Verbosity Tradeoff



Verbosity / Inaccuracy

■ pixels/ voxels

■ piecewise linear polyhedra

■ low degree piecewise non-linear

■ single general functions

Complexity / Accuracy

Summary



- Raw data
 - Point cloud
 - Range image
 - Polygon soup
- Surfaces
 - Mesh
 - Subdivision
 - Parametric
 - Implicit
- Solids
 - Voxels
 - BSP tree
 - CSG
 - Sweep
- High-level structures
 - Scene graph
 - Skeleton
 - Application specific