

# Achieving Single Channel, Full Duplex Wireless Communication

Jung Il Choi<sup>†</sup>, Mayank Jain<sup>†</sup>, Kannan Srinivasan<sup>†</sup>, Philip Levis, Sachin Katti  
Stanford University  
California, USA

{jungilchoi,mayjain,srikank}@stanford.edu, pal@cs.stanford.edu, skatti@stanford.edu

<sup>†</sup>Co-primary authors

## Abstract

This paper discusses the design of a single channel full-duplex wireless transceiver. The design uses a combination of RF and baseband techniques to achieve full-duplexing with minimal effect on link reliability. Experiments on real nodes show the full-duplex prototype achieves median performance that is within 8% of an ideal full-duplexing system.

This paper presents *Antenna Cancellation*, a novel technique for self-interference cancellation. In conjunction with existing RF interference cancellation and digital baseband interference cancellation, antenna cancellation achieves the amount of self-interference cancellation required for full-duplex operation.

The paper also discusses potential MAC and network gains with full-duplexing. It suggests ways in which a full-duplex system can solve some important problems with existing wireless systems including hidden terminals, loss of throughput due to congestion, and large end-to-end delays.

## Categories and Subject Descriptors

C.2.1 [Computer-Communication Networks]: Network Architecture and Design—*Wireless communication*

## General Terms

Design, Performance

## 1. INTRODUCTION

A basic precept of wireless communication is that a radio cannot transmit and receive on the same frequency at the same time, i.e. operate in a full duplex fashion. As wireless signals attenuate quickly over distance, the signal from a local transmitting antenna is hundreds of thousands of times stronger than transmissions from other nodes. Hence it has been generally assumed that one cannot decode a received signal at a radio while it is simultaneously transmitting.

This paper challenges that assumption, and shows via analysis and practical implementations on 802.15.4 radios that it is possible

to build full duplex radios. The implementation is fairly simple, and can be built using off-the-shelf hardware with software radios.

In theory, it is possible to build a full duplex, single channel radio using existing techniques. For a system with an antenna each for transmit and receive, since the system knows the transmit antenna's signal, it can subtract it from the receive antenna's signal and decode the remainder using standard techniques. For example, for 802.15.4 systems, which use 0dBm transmit power, the power of the transmit antenna's signal at a receive antenna placed 6 inches away is  $\sim 40$ dBm. The noise floor is  $\sim 100$ dBm, hence if we can remove 60dB of self-interference by cancellation, we can decode the receive antenna's signal.

One can envision implementing the above interference cancellation idea completely in the analog domain using noise cancellation circuits [17]. But practical noise cancellation circuits can only handle a dynamic range of at most 30dB [18], leaving us far off from our 60dB goal. Similarly, we could implement interference cancellation after ADC sampling in the digital domain using techniques such as ZigZag decoding [8]. But existing ADCs do not have the resolution to let the received signal through (which is 60dB below the noise floor due to the transmit signal's interference). Even when combined, these techniques cannot subtract 60dB of interference necessary to decode signal from the receive antenna.

This paper presents *antenna cancellation*, a novel technique for signal cancellation that allows us to implement practical full duplex radios. Antenna cancellation by itself provides  $\sim 30$ dB of signal cancellation, and in combination with noise cancellation and digital interference cancellation, provides around 60dB reduction, allowing a node to simultaneously transmit and receive.

The basic idea behind antenna cancellation is to use two transmit and one receive antenna. For a wavelength  $\lambda$ , the two transmit antennas are placed at distances  $d$  and  $d + \frac{\lambda}{2}$  away from the receive antenna. Offsetting the two transmitters by half a wavelength causes their signals to add destructively and cancel one another. This creates a *null position* where the receive antenna hears a much weaker signal. We can then apply noise cancellation and digital interference cancellation on the weaker signal to remove any residue.

The evaluation presented in this paper explores how antenna placement affects cancellation and the signal profile at the transmit antenna's intended receiver. Also, since antenna placement is dictated by a single carrier frequency while wireless transmission uses a band of frequencies, we study the impact of bandwidth on antenna cancellation. We show that for narrowband systems, the technique is sufficiently robust.

This paper combines three self-interference cancellation schemes, antenna cancellation, RF interference cancellation, and digital cancellation, to implement a practical 802.15.4 full-duplex radio. It

Permission to make digital or hard copies of all or part of this work for personal or classroom use is granted without fee provided that copies are not made or distributed for profit or commercial advantage and that copies bear this notice and the full citation on the first page. To copy otherwise, to republish, to post on servers or to redistribute to lists, requires prior specific permission and/or a fee.

*MobiCom '10*, September 20–24, 2010, Chicago, Illinois, USA.  
Copyright 2010 ACM 978-1-4503-0181-7/10/09 ...\$10.00.

provides results from real world experiments showing the feasibility of a full-duplex design. The full-duplex prototype comes within 8% of the performance of an ideal full-duplex system. The ideal full-duplex system would double the aggregate throughput compared to a half-duplex system, while the prototype achieves 84% median physical layer throughput gain compared to half-duplex operation.

There are three basic limitations to our design: transmit power, size and bandwidth. Because the combination of techniques have a limited potential to cancel up to  $\sim 80$ dB of signal, very strong transmitters cannot be canceled. For example, it cannot completely cancel transmitters that are higher than 20dBm: WiFi is just within the realm of possibility. This limitation can be overcome with the use of more precise components for implementing antenna and RF interference cancellation. In terms of size, the design requires at least  $\frac{\lambda}{2}$  in addition to regular antenna spacing. Our current prototype, for example, uses the 2.4GHz band and approximately 7 inches of space for antenna placement (in 5.1GHz, the antenna placement may be closer). This means that while such an antenna design can be part of an access point or laptop body, it cannot easily fit in a PCI-Express wireless card.

Antenna cancellation, as described in this paper, has a fundamental limit in performance for any given bandwidth. This makes antenna cancellation less effective for signals with bandwidth  $> 100$ MHz. Many current and planned future wireless technologies do not use much more bandwidth than 100MHz. Some components used in this paper are also limited in their operation over larger bandwidths. The noise cancellation circuit, for example, shows degraded performance when used with 20MHz 802.11 signals as compared to 5MHz 802.15.4 signals.

The full-duplexing scheme uses two RF chains per node to achieve nearly twice the throughput of a half-duplex system. A natural follow-up question is if this method is any better than using a 2x2 MIMO system, which can also potentially double throughput using 2 RF chains per node. However, the potential gains due to full-duplex go beyond the physical layer. With new media access control (MAC) layer designs that support full duplex, some of the most challenging problems in wireless networks can be mitigated, including hidden terminals, congestion, and end-to-end delay in multihop networks. Section 6 discusses some of these potential implications in detail.

## 2. WIRELESS FULL DUPLEXING

This section examines why existing cancellation techniques, RF and digital, are not enough to achieve full-duplex.

To understand the challenges in implementing wireless full-duplex, we need to understand the way signals are received at wireless nodes. The received signal from the antenna is amplified through an automatic gain control stage (AGC) and downconverted to either baseband or intermediate frequency, filtered and then sampled through an Analog-to-Digital Converter (ADC) to create digital samples.

The accuracy of digital samples depends on the resolution of the ADC. The AGC adjusts the gain of the received signal to match the maximum level of the ADC to get maximum resolution in the received signal. For the receiver to decode a weaker signal using digital cancellation, the signal needs to be strong enough to be captured within the resolution of the ADC. Typical ADCs are 8-12 bit, representing a range of 48-72dB. For an 8-bit ADC, if the weaker signal is 40dB lower in power than the stronger signal, it only gets 1-bit resolution.

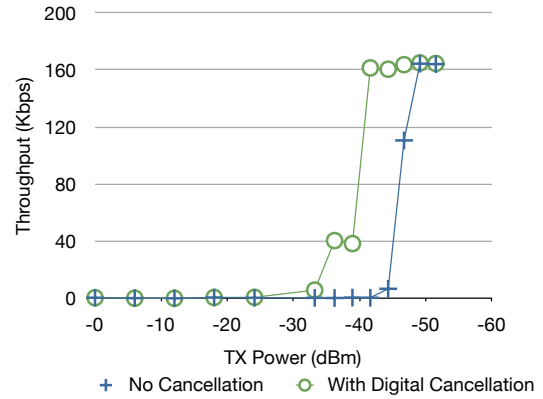

**Figure 1: Receive throughput using digital interference cancellation with varying self-interference signal power. Digital interference cancellation gives an SNR gain of only about 10dB, while full-duplexing in this setup requires  $\sim 46$ dB.**

### 2.1 Limitation of Existing Interference Cancellation Schemes

A small experiment shows the inefficacy of using only interference cancellation on digital samples to implement a full-duplex node. The “full-duplex” node used for this test has a receive RF board trying to decode packets from a 802.15.4 transmitter placed a few meters away. The 802.15.4 node transmits packets at 0dBm power. The receiver has a perfect link with an SNR of  $> 10$ dB to the 802.15.4 transmitter. A second RF board on the full-duplex node continuously transmits packets causing interference at the receiver. A digital cancellation technique is used to try and cancel the node’s self-interference. We defer the details of this technique to Section 4.2.

Figure 1 shows the resulting throughput for different transmit powers of the self-interference signal. Even with digital cancellation, the self-interference signal transmit power needs to be  $\sim 36$ dB lower than the transmit power of the intended transmitter for the receiver to receive any intended packets. As a comparison, the figure also shows that the receiver can receive intended packets, without any digital cancellation, only if the transmit power of the (self-)interferer is  $\sim 46$ dB lower than the intended transmitter. Thus, digital cancellation gives an SNR gain of 10dB. For a true full-duplex operation, we want the transmit powers of the intended and interfering transmitters to be equal.

This shows the limitation of using existing digital interference cancellation techniques for achieving full-duplex. A node’s transmit signal completely overwhelms its receive ADC such that the digital samples do not retain any information of the weaker signal that a node is trying to receive.

Another option is to use an existing RF interference cancellation chip [17] to reduce self-interference before sending the signal through the ADC stage. An evaluation shows that this technique can achieve a reduction in interference of  $\sim 25$ dB [18]. A combination of RF and digital interference cancellation still falls short of being able to reduce interference enough to make full-duplex feasible.

This paper introduces an additional mechanism, *Antenna Cancellation* to further reduce the effect of self-interference. After combining antenna cancellation with RF interference cancellation, the received digital samples retain enough resolution of the desired received signal that digital interference cancellation techniques be-

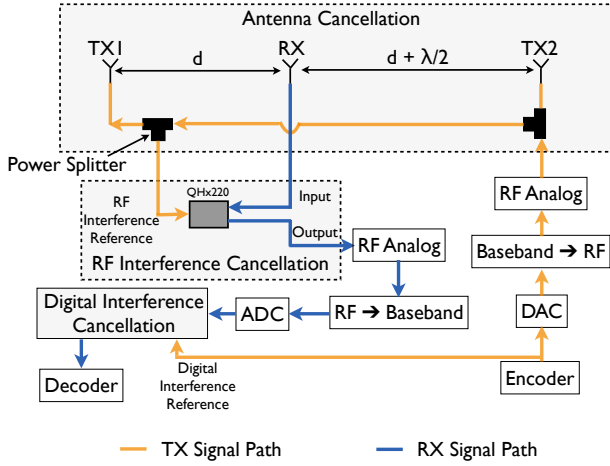

**Figure 2: Block diagram of a wireless full-duplex node. Colored blocks correspond to different techniques for self-interference cancellation. The power splitters introduce a 6dB reduction in signal, thus power from TX1 is 6dB lower compared to power from TX2, without the need for an additional attenuator.**

come feasible. A brief overview of the antenna cancellation scheme follows.

## 2.2 Antenna Cancellation

This scheme uses the insight that transmissions from two or more antennas result in constructive and destructive interference patterns over space. In the most basic implementation, the transmission signal from a node is split among two transmit antennas. A separate receive antenna is placed such that its distance from the two transmit antennas differs by an odd multiple of half the wavelength of the center frequency of the transmission.

For example, if the wavelength of transmission is  $\lambda$ , and the distance of the receive antenna is  $d$  from one transmit antenna, then the other transmit antenna is placed at  $d + \lambda/2$  away from the receive antenna. This causes the signal from the two transmit antennas to add destructively, thus causing significant attenuation in the signal received, at the receive antenna.

Destructive interference is most effective when the signal amplitudes at the receiver from the two transmit antennas match. The input signal to the closer transmit antenna is attenuated to get the received amplitude to match the signal from the second transmit antenna, thus achieving better cancellation. A general implementation could use differently placed or more than three antennas to achieve better cancellation.

Antennas are optimally placed only for line-of-sight (LOS) components. If antennas are placed in a corner, for example, the reflected signals from each transmit antenna will not necessarily cancel. While this puts a fundamental limitation on the performance of the antenna cancellation, signal strength of the reflected signals is typically much weaker than LOS due to longer signal path and attenuation when reflected. It is possible to bring this signal into the dynamic range of the ADC by using RF interference cancellation after the antenna cancellation stage.

Figure 2 shows a block diagram of a system incorporating all the techniques for full-duplex operation. While each technique has its own limitations, this paper shows connecting all three techniques in series can overcome the limitations.

## 3. ANTENNA CANCELLATION

This section analyzes the possible reduction in self-interference by using antenna cancellation. It also evaluates its limits with respect to bandwidth of the signal being transmitted and the sensitivity of antenna cancellation to engineering errors. It shows, using actual measurements, that antenna cancellation achieves 20dB reduction in self-interference. This section also evaluates the effects of using two transmit antennas for antenna cancellation on the communication range. It shows that antenna cancellation degrades the received signal at other nodes in the network by at most 6dB compared to the single antenna setup.

### 3.1 Performance of Antenna Cancellation

In an ideal scenario, the amplitudes from the two transmit antennas would be perfectly matched at the receiver and the phase of the two signals would differ by exactly  $\pi$ . However, we find that the bandwidth of the transmitted signal places a fundamental bound on the performance of antenna cancellation. Further, real world systems are prone to engineering errors which limit system performance. The sensitivity of the antenna cancellation to amplitude mismatch at the receive antenna and to the error in receive antenna placement is important to consider.

To analyze the reduction in interference using antenna cancellation, we look at the self-interference signal power at the receive antenna after antenna cancellation. It is derived in Appendix A to be:

$$2A_{ant} \left( A_{ant} + \epsilon_{ant}^A \right) |x[t]|^2 \left( 1 - \cos \left( \frac{2\pi \epsilon_{ant}^d}{\lambda} \right) \right) + \left( \epsilon_{ant}^A \right)^2 |x[t]|^2$$

where  $A_{ant}$  is the amplitude of the baseband signal,  $x[t]$ , at the receive antenna received from a single transmit antenna.  $\epsilon_{ant}^A$  is the amplitude difference between the received signals from the two transmit antennas at the receive antenna.  $\epsilon_{ant}^d$  represents the error in receiver antenna placement compared to the ideal case where the signals from the two antennas arrive  $\pi$  out of phase of each other. This equation lets us evaluate the sensitivity of antenna cancellation to receive antenna placement, change of transmit frequency, and amplitude matching at the receive antenna.

$\epsilon_{ant}^d$  also captures the effect of bandwidth on antenna cancellation. Consider a 5MHz signal centered at 2.48GHz. Thus, the signal has frequency components between 2.4775GHz and 2.4825GHz. If the receive antenna is placed perfectly for the center frequency, there is a small error in placement for the other frequencies within that bandwidth.

We can map the difference in wavelength to the error in receiver placement. For example, a  $\delta$  difference in wavelength is similar to a  $\delta/4$  error in receiver placement. Thus,  $\epsilon_{ant}^d$  for 2.4775GHz in this case would be  $\sim \frac{1}{4} \left( \frac{c}{2.4775 \times 10^6} - \frac{c}{2.48 \times 10^6} \right)$ , where  $c$  is the speed of light. This gives  $\epsilon_{ant}^d \sim 0.025mm$ , corresponding to 60.7dB antenna cancellation for the 2.48GHz center frequency. Thus, 60.7dB is the best antenna cancellation possible for a 5MHz signal in the 2.4GHz band using the 3 antenna scheme described in this paper. Similarly, using 20MHz and 85MHz bandwidths give best case reduction of 46.9dB and 34.3dB respectively.

As can be seen from the effect of bandwidth, antenna cancellation does not provide a frequency flat channel at the receiver if there is perfect amplitude matching. This distortion in the received signal can be a problem for the RF and digital interference cancel-

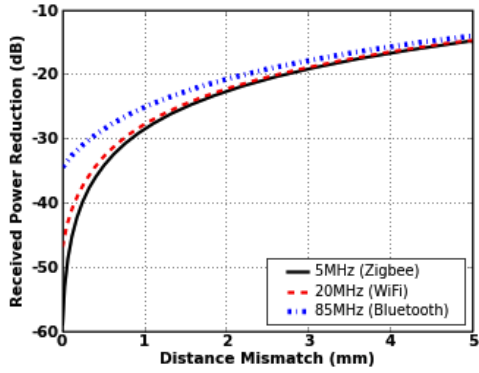

(a) Received power with distance mismatch

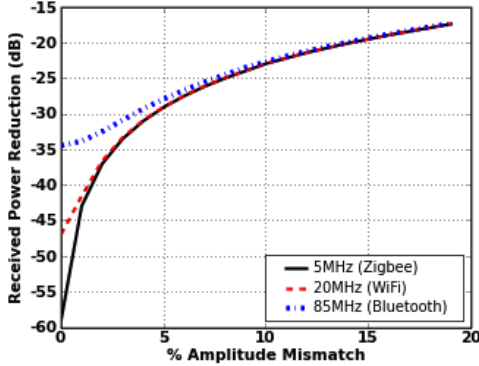

(b) Received power with amplitude mismatch

**Figure 3: Performance of antenna cancellation with distance and amplitude mismatch for signals with different bandwidth. A 1mm mismatch can restrict the receive power reduction to  $\sim 29$ dB. An amplitude mismatch of 10%, corresponding to 1dB variation, can restrict the receive power reduction to  $\sim 20$ dB.**

lation stages, since they use the undistorted transmission signal as reference for cancellation.

Any error in receive antenna placement adds to  $\epsilon_{ant}^d$ . To see the effect of receive antenna placement error, suppose the receive antenna is 1mm off from the optimal position, i.e.  $\epsilon_{ant}^d = 1mm$ . With perfect amplitude matching and with a  $\lambda$  of 12.1cm (for a center frequency of 2.48GHz), we see a 28.7dB reduction in power compared to no antenna cancellation. Figure 3(a) shows the theoretical performance of antenna cancellation with error in receiver placement, for different bandwidths.

Figure 3(b) shows the theoretical performance of antenna cancellation with error in amplitude matching, assuming perfect center frequency receiver placement, for different bandwidths. For example, say the amplitude of one signal is 10% higher than the other, i.e.  $\epsilon_{ant}^A = 0.1 * A_{ant}$ . In this case, the powers of the two signals differ by  $\sim 1dB$ . With this  $\epsilon_{ant}^A$ , the reduction in received power due to antenna cancellation is 23dB, if we ignore the effect of bandwidth. For a 5MHz bandwidth, the same  $\epsilon_{ant}^A$  gives a 22.994dB reduction. Thus, a small amplitude mismatch tends to dominate the performance restrictions on antenna cancellation. Since amplitude mismatch affects different frequencies equally, the resulting frequency response is fairly flat, thus giving a less distorted input to the later cancellation stages. Thus, amplitude mismatch may end up helping the later stages of interference cancellation.

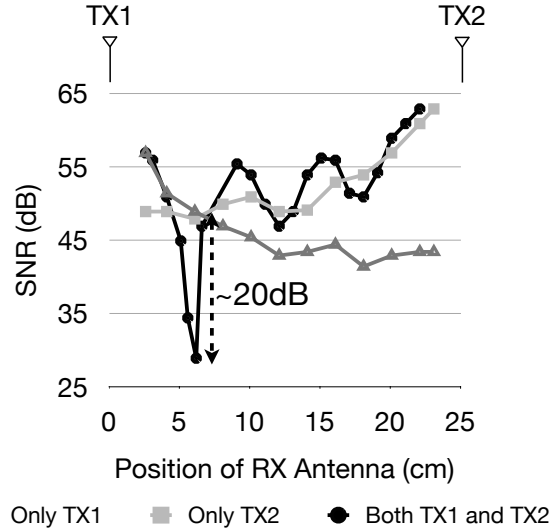

**Figure 4: Received SNR for different receive antenna placements. The received SNR is fairly monotonic with distance when any one transmit antenna is active. With both transmit antennas active, there is a sharp reduction in receive power at the null point.**

### 3.2 Antenna Cancellation in Practice

Figure 4 shows the effect of antenna cancellation with transmitter TX1 attenuated by 6dB compared to TX2. Experiments show that the received power from the two TX antennas differs by about 5.1dB when the receiver is placed at the null point. Thus, this setup has an amplitude mismatch of  $\sim 1dB$  causing the cancellation to be restricted to  $\sim 20dB$  as shown in the previous analysis. The above analysis did not consider the multipath effect. However, results from the measurements show that the multipath effect is not a dominant component in our experimental setup.

### 3.3 Effect of Antenna Cancellation on Intended Receivers

While antenna cancellation can reduce self-interference from a node's own transmitter, an important question is how this affects the received signal at nodes other than the transmitter. Another question is how does our cancellation technique compare to a simple technique such as having the signals between the two transmit antennas phase shifted by  $\pi$ . Unlike our technique, the phase shift approach does not require an attenuator and gives a null point exactly at the center.

The contour map in Figure 5(a) shows received power with both transmit antennas transmitting a single frequency tone at the same power with a phase difference of  $\pi$  using a simple simulation with a freespace propagation model. Each contour line corresponds to a specific received power. Figure 5(b) shows the received signal strength with different transmit powers from the transmit antennas such that amplitudes match at the null point without any phase shift in antenna signals. The null points achieved in the two cases are at different locations, but both schemes are equally good in terms of signal reduction at the null point.

The difference between these two cases becomes clearer by looking at the received signal at larger distances. Figure 5(c) shows the received signal strength profile, over space, for a single transmit antenna over a distance of 30m from the transmitter. This is the baseline for comparison of the two schemes with antenna cancella-

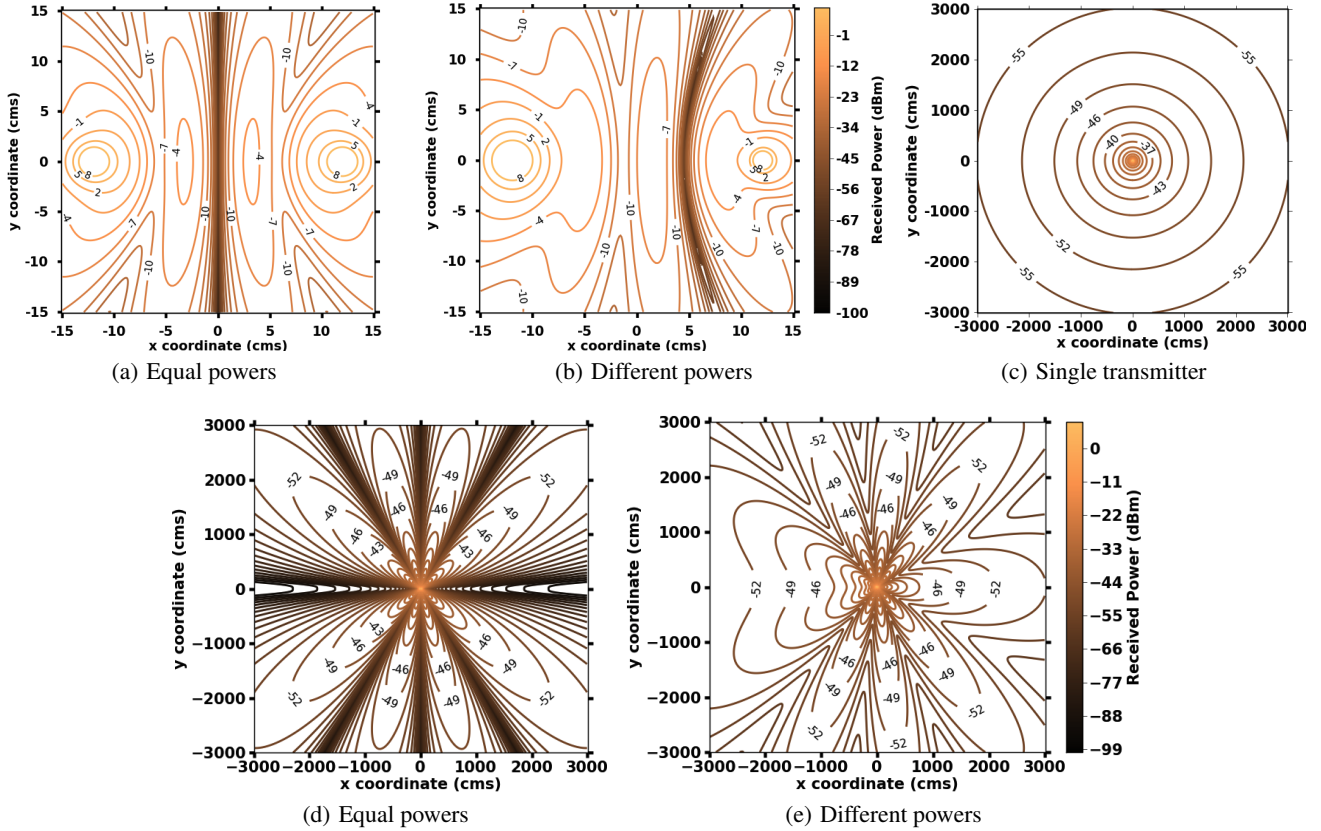

**Figure 5: Freespace signal strength profiles for equal transmit powers and different transmit powers on two transmit antennas. This simulation uses a pathloss exponent of 2. Figures (a) and (b) correspond to a short-range study. When transmit powers are equal, the minimum received signal is in the middle and when the transmit powers are different, the minimum is closer to the lower transmit power antenna. Figures (c), (d) and (e) correspond to a long-range study. When transmit powers are equal, receivers equidistant from the transmit antenna pair can see huge differences in the received signal strength. When transmit powers are different, however, such differences are much smaller.**

tion. Figure 5(d) shows the contours over larger distances for the same setup as Figure 5(a). It is apparent that even in normal communication range, there are locations with very low received power due to the destructive interference.

Figure 5(e) shows the contours of received power when one transmit signal is attenuated by 6dB compared to the other and there is no phase shift between the two transmitted signals. The effect of destructive interference is much lower in this case.

In case of two transmit antennas, the signals from the two antennas get added constructively or destructively at the receiver. At distances much larger than the spacing between the transmit antennas, the signals from both antennas undergo almost equal attenuation. With equal receive power from both antennas, a perfectly destructive combining of the two signals causes the received signal to be zero power. In case of unequal transmit powers, the received power at these distances is different from the two transmit antennas. Even when the signals combine perfectly out of phase, the resulting signal is not zero power.

Comparing with the single antenna case, using our antenna cancellation scheme leads to a maximum degradation of 6dB at any receiver location. In a real network setting, diversity gains due to two transmit antennas would offset this degradation. Thus, antenna cancellation can give significant reduction at the null position without having a large effect on reception at other nodes. Following

antenna cancellation, further reduction is obtained by RF and digital interference cancellation techniques.

## 4. INTERFERENCE CANCELLATION

This section explains two interference cancellation mechanisms used in full-duplexing nodes after the antenna cancellation stage. The first is RF interference cancellation using a noise canceler. The second is digital cancellation that takes place, in software, after the received signal is discretized.

### 4.1 RF Interference Cancellation

As Radunovic et al. [18] explored for 900MHz band networks, the interference cancellation circuit based on QHx220, a noise canceler chip, allows removing a known analog interference signal from a received signal. The QHx220 chip takes the known self-interference and received signals as inputs and outputs the received signal with the self-interference subtracted out. The chip allows changing the amplitude and phase of the interference reference signal to match the interference in the received signal. An RF splitter is used to give the transmit signal to the cancellation circuit as the interference reference.

Figure 6 shows the effect of using the RF cancellation circuit. It shows spectrum power snapshots at the receive antenna for three

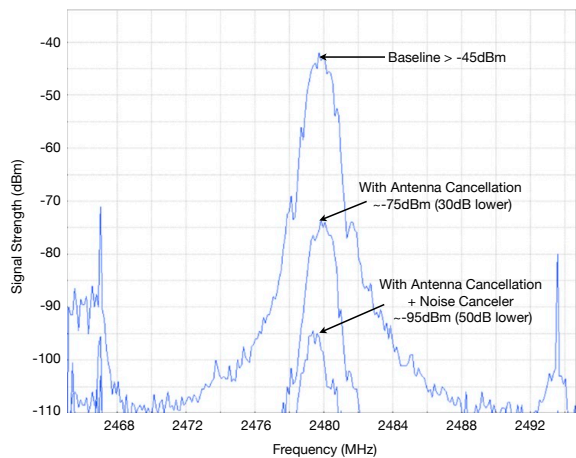

**Figure 6: Spectrum snapshots showing the effect of antenna cancellation and a combination of antenna and RF interference cancellation. A combination of the two techniques can give a  $\sim 50$ dB reduction in self-interference.**

cases – the maximum receive antenna power with only one transmitting antenna, the receive power with antenna cancellation and the receive power with a combination of antenna and RF interference cancellation. RF interference cancellation achieves  $\sim 20$ dB reduction in the received self-interference on top of the reduction achieved by antenna cancellation.

## 4.2 Digital Interference Cancellation

There is extensive existing work that describes digital cancellation techniques [8, 9, 10]. Traditionally, digital cancellation is used by a receiver to extract a packet from a desired transmitter after the packet has collided with a packet from an unwanted transmitter. To do this, the receiver first decodes the unwanted packet, remodulates it and then subtracts it from the originally received collided signal. In case of canceling self-interference for full-duplex, the transmitted symbols are already known, and thus decoding is not necessary in order to reconstruct a clean signal.

Instead of decoding, coherent detection is used to detect the self-interfering signal. The detector correlates the incoming signal with the clean transmitted signal, which is available at the output of the transmitter. The main challenge in subtracting the known signal is in estimating the delay and phase shift between the transmitted and the received signals. As the detector has the complete knowledge of originally transmitted signal, it uses this signal to correlate with the incoming signal to detect where the correlation peaks. The correlation peak technique gives both the delay and the phase shift needed to subtract the known signal. Thus, this technique, unlike some of the digital interference techniques, does not require any special preamble or postamble and is backwards compatible. Moreover, this technique is modulation-independent as long as the clean signal can be constructed.

Coherent detection can detect the self-interference signal even when it is weaker than the received signal. Therefore, digital interference cancellation can improve the SINR level even when the received signal is stronger than self-interference. This property is useful when operating with variable data rates to allow using higher data rates for high SNR links.

Typical interference cancellation also requires compensating for clock drift between the transmitter and receiver. Since the transmitter and receiver daughterboards in a full-duplex node share the

Section	Summary
Section 5.2	Aggregate Throughput for full-duplex links shows 1.84x median gain.
Section 5.3	Full-duplex links maintain 88% of the half-duplex link reliability.
Section 5.4	Without digital interference cancellation, full-duplex maintains only 67% of the half-duplex link reliability.

**Table 1: Summary of evaluation results**

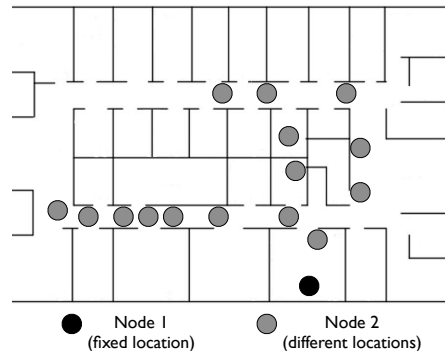

**Figure 7: Map of node locations for the experimental setup. Node 1 is always kept at a fixed location inside an office room and Node 2’s location is changed for each iteration to different locations within a building wing.**

same clock, there is no clock drift. However, since the daughterboards use separate PLL logic, there can be a jitter introduced. We believe this jitter is what limits the performance of the current implementation of digital interference cancellation.

Currently, our digital interference cancellation achieves  $\sim 10$ dB reduction, which is much smaller than reported by SIC [9],  $\sim 20$ dB. We believe it can be improved by incorporating a channel estimator. Since the actual self-interference signals are different from the generated transmitted signals due to hardware limitations and multipath, correlating and subtracting the estimated signal rather than the clean signal can improve performance.

## 5. EVALUATION

Doing full-duplex transmissions has implications to throughput and packet delivery reliability. As transmission and reception can go simultaneously, the aggregate throughput for a node pair can be more than a half-duplex system. On the other hand, improper cancellation can lead to a strong self-interference and hurt packet reception while transmission is in progress. An ideal full-duplex system should have perfect self-interference cancellation and achieve double the throughput of a half-duplex system. Our evaluations using a preliminary prototype show that full-duplexing gives a median aggregate throughput gain of 84% without significant loss in packet reception reliability. In other words, the full-duplex prototype’s performance is within 8% of an ideal full-duplex system. More precise engineering can allow for even better implementations. This evaluation shows the feasibility of making a full-duplex wireless system. Table 1 summarizes these evaluation results.

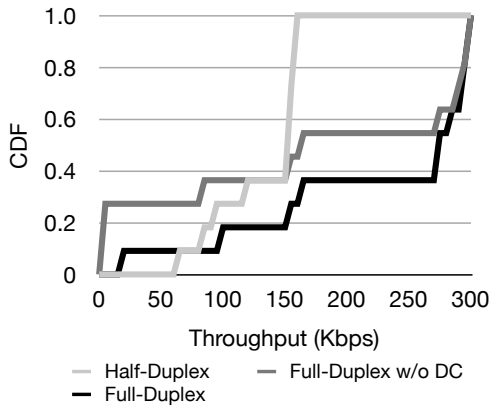

**Figure 8: Aggregate throughput of half-duplex links, full-duplex without digital interference cancellation, and full-duplex. Full-duplex links can achieve 84% higher median throughput.**

### 5.1 Experimental Setup

To study the effects on the throughput and link reliability, we instrumented two USRPv1 nodes with the antenna and RF cancellation setups. Each USRP node has two 2.4GHz ISM radio daughterboards (RFX2400); one is used for transmit and the other for receive, at the same time.

Due to the lack of support for 802.11 PHY in USRP radios, we used an existing modulation/demodulation scheme for 802.15.4 (Zigbee) [20], which uses OQPSK with raw data rate of 250Kbps. We matched the total transmit power from two antennas to be the same as the transmit power from a typical 802.15.4 mote (MicaZ), 0dBm. Our experiments run on a band with a center frequency of 2.48GHz, channel 26.

The setup includes one full-duplex node kept at a fixed location inside an office room and the second full-duplex node placed at 15 different locations in the corridor, next to the office room. These experiments are run in the Gates Computer Science Building at Stanford University, where transmissions from other wireless networks, such as 802.15.4, 802.11, and Bluetooth, are common. Figure 7 shows a map of the node locations. Different locations give data-points for different SNR ranges, from very high ( $\sim 35dB$ ) to very close to the noise floor ( $\sim 0dB$ ). For each location, we collect traces with each node transmitting individually for 30 seconds, and then both nodes transmitting together for 30 seconds. Each node transmits packets of 119 bytes at a rate of 160 packets/sec. This rate of packet transmission ensures significant overlap between the packets in the two directions.

### 5.2 Aggregate Throughput

To calculate the aggregate throughput of the half-duplex system, the throughput of the two single directional flows are averaged. This gives the throughput of a half-duplex system with the optimal scheduling without contention. For the full-duplex system, the throughput for each direction, when both the flows are active, are added.

Figure 8 shows the gain in aggregate throughput from using wireless full-duplex. In this section, we only compare the half-duplex with the full-duplex. We defer the discussion of full-duplex without digital interference cancellation to Section 5.4.

When half-duplex links cannot deliver any packets, using full-duplexing does not help since it does not increase the SNR (not shown in the plot). When the link SNR is close to the noise floor,

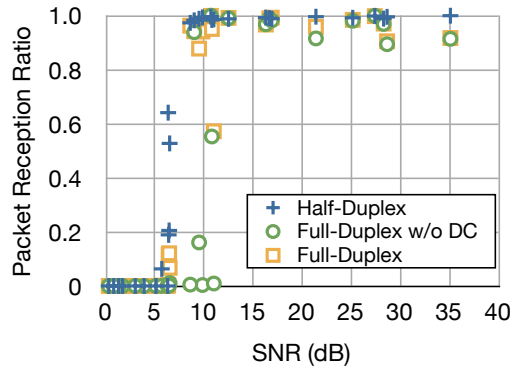

**Figure 9: Packet reception ratio vs SNR for different links. Full-Duplex achieves a similar SNR curve as half-duplex, but it shows lower PRR for high-SNR links.**

half-duplex links show better throughput. Imperfect interference cancellation results in residual self-interference that reduces SNR, resulting in a lower throughput for full-duplexing.

Except for the locations where the link SNR is very low, full-duplexing can almost double the throughput. Overall, the median throughput gain of full-duplex is 84%. The average throughput for half-duplex links is 130Kbps, and for full-duplex links, it is 222Kbps.

A look into packet traces shows that the full-duplex setting has a larger time interval between successive packet transmissions as compared to the half-duplex traces. The reason is the CPU load caused from extra processing required for receiving packet samples at the same time in the RX path. Correspondingly, the full-duplex system has around 5% fewer transmitted packets. Our throughput numbers are not compensated for this effect. Perfect CPU isolation for the transmit and receive paths will improve full-duplex throughput.

### 5.3 Link Reliability and Full-Duplex

If cancellation techniques were perfect, the SNR, after cancellation, will be the same as the half-duplex SNR. However, this paper does not achieve perfect full-duplex behavior. Thus, there is residual interference, which reduces the SNR and causes packet drops.

Figure 9 shows the packet reception ratio versus SNR for different links. The PRR transition region is similar for half-duplex and full-duplex (6-8dB), which suggests that full-duplex can mostly cancel out the self-interference signal. However, while half-duplex links maintain a PRR close to 1 for links with high SNR, full-duplex suffers some loss in reliability regardless of SNR. In average, full-duplex links maintain 88% of the link reliability compared to half-duplex links.

The cause of PRR loss at high SNR is not certain. Since the signal is up to  $\sim 30dB$  higher than the self-interference, we believe that the losses in full-duplex links are not caused by self-interference. Raw traces for full-duplex operation show some unaccounted for signal peaks which may cause loss of PRR. These peaks may be because of a misbehaving USRP, or an effect of signal overflow/underflow due to CPU overload. As the causes of these signal peaks are unknown, it is not possible to digitally cancel them. Further, CPU load causes buffer underflows in transmission and overflows in reception, which can lead to loss in packet receptions. A full-duplex node has to process double the number of packets, since it transmits and receives at the same time.

Note that the PRR transition region for half-duplex is shifted to

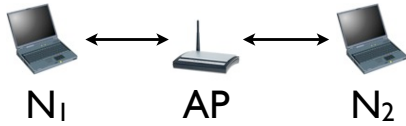

**Figure 10: An infrastructure Wi-Fi setup. A hidden terminal occurs at the AP when node  $N_1$  and  $N_2$  cannot hear each other's transmissions**

the right by  $\sim 6$ -7dB compared to the typical 802.15.4 system, for which the transition region occurs around 0dB. Besides the effect of longer packets, we believe that this difference is also due to the limitations of the implementation of the 802.15.4 receiver in US-RPs as reported in [20].

## 5.4 Digital Interference Cancellation

Since digital interference cancellation is not possible with an off-the-shelf transceiver, we study full-duplex performance without using digital cancellation.

Figures 8 and 9 show the results of full-duplex without performing digital interference cancellation to understand the gains in the absence of digital interference cancellation. Figure 9 shows that full-duplex without digital cancellation has 5dB higher PRR transition range. The gain of digital cancellation is only 5dB since the self-interference signal is only about 5dB above the noise floor after antenna and RF interference cancellation for this system.

Overall, full-duplex without digital interference cancellation maintains only 67% of the link reliability of the half-duplex links. Therefore, more links with low SNR do not sufficiently cancel out the self-interference, causing  $\sim 40\%$  of the links to have lower throughput than half-duplex. These results reveal that a reasonable full-duplex operation with off-the-shelf radios is possible only for high SNR link pairs. A more carefully tuned RF cancellation setup could allow full-duplex operation with off-the-shelf radios across a wider range of SNRs.

## 6. APPLICATIONS

Earlier sections showed that a wireless full-duplex system that can nearly double the throughput of a single hop link is practically implementable. On the other hand, the implementation uses additional resources that could otherwise be used to implement a 2x2 MIMO system, that may provide similar physical layer gains. It is unclear if only the physical layer gains of full-duplex would justify the engineering and cost needed to implement these systems.

However, we believe that the true benefit of the full-duplex system lies beyond this gain in the physical layer. Practical full-duplexing can mitigate many of the problems with wireless networks today. Full-duplexing helps address three distinct challenges in current wireless systems: hidden terminals, congestion due to MAC scheduling, and high end-to-end delays in multihop wireless networks. Further, full duplex can have applications to future wireless networks that use cognitive radios.

### 6.1 Reducing Hidden Terminals

Figure 10 shows a typical home or office Wi-Fi setup. End nodes connect to the backbone network through an access point. The classic hidden terminal problem occurs when Node  $N_2$  is unable to hear  $N_1$ 's transmissions to the access point and starts sending data to the access point at the same time, thus causing a collision at the access point.

This problem can be solved using full-duplex nodes. Suppose all nodes always have data to send to and receive from the access

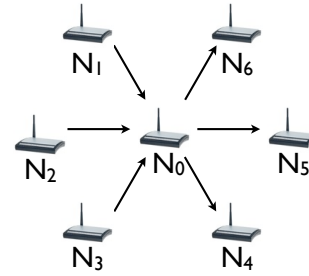

**Figure 11: A star topology multihop network. Node  $N_0$  becomes a congested node. The network throughput in regular MAC operation is  $1/n$  for  $2n+1$  nodes.**

point. Then, as soon as  $N_1$  starts transmitting data to the access point, the access point starts transmitting data back to  $N_1$  simultaneously.  $N_2$  hears the transmission from the access point and delays its transmission, thereby avoiding a collision. If the access point does not have any packets to send back to  $N_1$ , it can repeat whatever it hears. This repetition serves as an implicit ACK for  $N_1$  and prevents  $N_2$  from transmitting. This scheme for mitigating hidden terminals also applies to multihop wireless networks.

Full-duplexing does not completely prevent the hidden terminal problem. In order for the receiver to respond, it needs to receive the destination address of the link layer header. However, typically the destination address is preceded by the preamble, PHY header, and part of the MAC layer header, where collisions can still occur. For example, for 802.11g, the receiver needs to receive 15 bytes before it can decode the receiver address, which leaves the initial  $\sim 2.5\%$  of the packet time to be vulnerable for 6Mbps and  $\sim 10\%$  for 54Mbps, for a 1500 byte packet. This vulnerability is inevitable, but can be reduced by changing the packet format such that the destination address is placed earlier in the packet.

### 6.2 Reducing Congestion due to MAC Scheduling

Figure 11 shows a network in star topology. Nodes  $N_1$ ,  $N_2$ , and  $N_3$  have data to send to nodes  $N_4$ ,  $N_5$ , and  $N_6$  respectively. All data has to be routed through node  $N_0$ , and  $N_0$ - $N_3$  are in the interference range of each other. If all three source nodes have saturated flows to be sent to their respective destinations, nodes  $N_0$ - $N_3$  constantly contend with each other for channel access. Assuming typical MAC scheduling,  $N_0$  gets  $1/4^{th}$  the total transmission opportunities. This restricts the aggregate network throughput to  $1/4^{th}$  the capacity of one link.

In a general star topology with  $2n+1$  nodes and nodes  $N_1$  to  $N_n$  trying to route data to nodes  $N_{n+1}$  to  $N_{2n}$  respectively via node  $N_0$ , the aggregate network throughput is  $1/n$ .

With full-duplexing,  $N_0$  can transmit and receive at the same time. Thus, for each transmission from either node  $N_1$ ,  $N_2$ , or  $N_3$ ,  $N_0$  can forward a packet to a destination. Thus, the aggregate network throughput is equal to the single link capacity. Full-duplex helps solve the loss of network throughput due to congestion and MAC scheduling by allowing congested nodes to forward out packets and receive packets at the same time.

Existing work [5, 16] has also studied the problem of fairness between upstream and downstream flows in access point (AP) based networks. Since 802.11 CSMA provides the same transmit opportunities to all clients and the AP, the AP only gets  $1/N$  of the channel when there exist  $N$  clients. If the downstream flow is equally



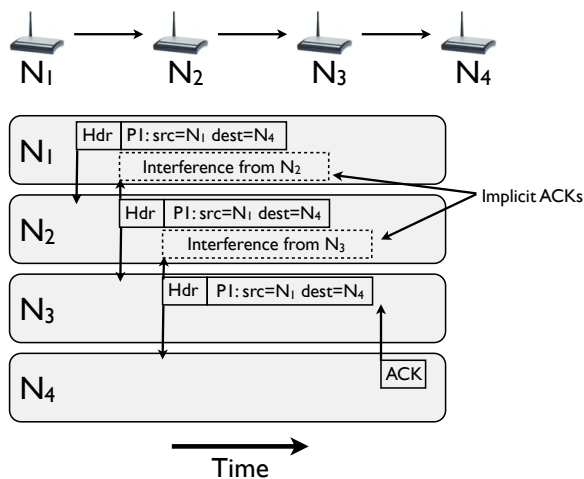

**Figure 12: Wormhole switching in a multihop network. Interference from forwarding hops can be canceled using digital cancellation and can also serve as implicit ACKs.**

divided into  $N$  clients, each flow gets only  $1/N^2$  of the channel capacity, while each upstream flow gets  $1/N$ .

Some suggested solutions to this problem include controlling the channel access priority or incorporating rate control mechanisms above the MAC layer [5, 16]. However, the congestion reduction offered by full-duplexing extends seamlessly to provide inherent fairness in AP based wireless LANs. Since APs can transmit while receiving, all downstream and upstream flows can get  $1/N$  of the channel capacity each.

### 6.3 Wormhole Routing in Multihop Networks

Multihop networks suffer from long end-to-end delays causing loss in performance for delay sensitive protocols like TCP. Further, multihop networks have a  $1/3^{rd}$  throughput scaling compared to single hop networks due to interference between forwarding hops.

The idea of receiving and forwarding at the same time can be extended to solve these problems. The insight is that as a full-duplex node is starting to receive a packet it can simultaneously start to forward it. Thus, instead of the default store-and-forward architecture, full-duplex nodes could forward a packet while receiving it. This idea is similar to wormhole switching [7] used for multihop wired communication networks. This technique can theoretically reduce the end-to-end delay for packet delivery through a multihop network from a packet time multiplied by number of hops to a little more than a packet time.

Figure 12 shows the way wormhole switching can work for full-duplex wireless links.  $N_2$  starts receiving a packet from  $N_1$ . As soon as  $N_2$  has processed the packet header, it knows where to forward the packet and starts transmitting the packet to  $N_3$ . Similarly,  $N_3$  starts forwarding the packet to  $N_4$ . At this time,  $N_3$ 's transmission also interferes with the reception at  $N_2$ . Since  $N_2$  knows the part of the packet  $N_3$  would be transmitting at this time, it can use digital cancellation techniques to cancel  $N_3$ 's transmission. Further, once  $N_2$  has finished receiving the packet from  $N_1$ , it can again apply digital cancellation to previously received samples from  $N_1$  and  $N_3$  to cancel the samples received from  $N_1$ . This allows  $N_2$  to check the packet transmission from  $N_3$ . This can act as an implicit ACK mechanism, thus removing the need of an explicit ARQ scheme. The last node in the route sends an explicit ACK to the last but one node in the route. Existing work has suggested a similar im-

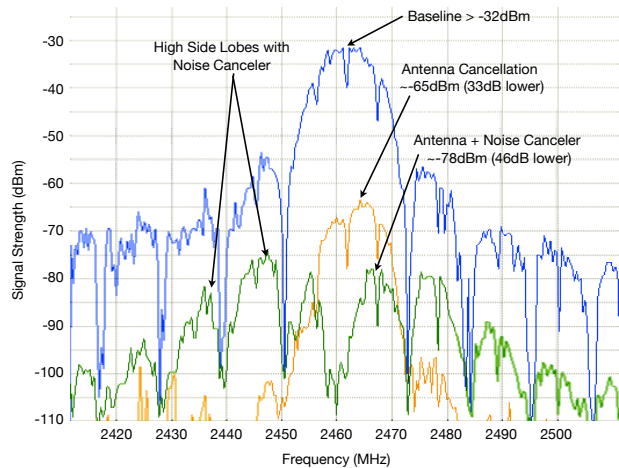

**Figure 13: Spectrum at received antenna for a Wi-Fi node transmitting at full power (18dBm). Antenna cancellation gains are as expected. RF interference cancellation results in high sidelobes.**

PLICIT ARQ scheme for a multi-channel wireless network used as an interconnect backbone for chip multi-processors [15].

### 6.4 Cognitive Radios

In cognitive radio technologies such as WhiteFi [2], the unlicensed (secondary) users are allowed to use a spectrum only if the licensed (primary) users are not using it. One of the primary challenges in such systems is to identify *when* it is okay for secondary users to use the spectrum. Specifically, while the secondary user is using the spectrum, if the primary user decides to use the spectrum then it is usually hard for the secondary users to detect and stop immediately. The full-duplex system proposed in this paper will enable the secondary user to scan for any primary users while it is using the spectrum.

## 7. CHALLENGES

Previous sections have shown the feasibility of full duplex for 802.15.4 systems. As wireless systems like 802.11 have (100x) higher transmit power and (4x) wider bandwidth than 802.15.4, it is not clear if full duplex is possible in such systems. Preliminary exploration shows that higher transmission power calls for better antenna cancellation and digital cancellation techniques, and wider bandwidth calls for better noise cancellation circuitry.

### 7.1 Full Duplex in 802.11

Figure 13 shows the spectrum analyzer outputs with and without antenna and noise cancellation techniques. It shows that the reduction is  $\sim 48$ dB when the two RF cancellation techniques are used. The RF interference cancellation step (using a noise cancellation circuit) results in several high power sidelobes, although it gives a 15dB reduction in signal at the center frequency. This result is different from the spectrum observed for 802.15.4 in Section 3. There are two differences between 802.11 and 802.15.4 systems; higher power and wider bandwidth. Below, we explore how these two properties affect full duplex in 802.11 systems.

### 7.2 High Transmit Power

The three cancellation techniques presented in this paper, together, give  $\sim 60$  dB reduction of self interference for the current implementation. For a 802.15.4 system, at the receiver location,

this reduction is enough to bring down the self interference close to the noise floor of the receiver. If the transmission power is increased by 20 dB, however, the self-interference will be significantly above the noise floor and will reduce the full duplex range.

The antenna cancellation technique used in the proposed system is far from optimal; the attenuator used has a 1dB granularity. As Section 3 pointed out, small mismatches in amplitude can cause huge reductions in cancellation. This leaves room for further reduction in self interference. In the future, we will explore using RF attenuation circuitry used by MIMO systems that can finely control how transmit power is distributed between the two transmit antennas.

Furthermore, as discussed in Section 4.2, the digital cancellation technique that is currently used does not estimate the hardware effect and the channel between the transmit antennas and the receive antenna. A channel estimation technique combined with the existing digital cancellation will give further self interference reduction,  $\sim 10$ dB.

### 7.3 Wide Bandwidth

The noise cancellation circuitry used in the proposed system is not capable of canceling wideband interference. A perfect noise canceler should cancel the reference signal completely down to the noise floor. However, as Figure 13 shows, the noise canceler has reasonably good cancellation only for a short band; the received signal is down by 13dB over  $\sim 15$ MHz. Beyond this small bandwidth, however, the cancellation is poor. In fact, the sidelobes at the output of the noise canceler circuit are of higher power than the input to the circuit. Further investigation on a noise canceler that can work over a wideband is needed to extend the current system to wideband systems such as 802.11 and Bluetooth.

## 8. RELATED WORK

Multiple-input multiple-output (MIMO) systems use multiple antennas at the transmitters and receivers for increasing aggregate throughput. As our full-duplex system uses two RF chains, it is fair to compare our performance with a 2x2 (two antennas at both the transmitter and the receiver) system. For a 2x2 MIMO system, with perfect knowledge at the transmitter, the capacity is twice that of a single antenna system. As shown in Section 5, a practical full-duplex system is realizable without channel knowledge at either the transmitter or receiver. Moreover, unlike full-duplex systems, MIMO systems are still prone to hidden terminal problems. Furthermore, wormhole routing is not possible with MIMO systems.

The ideas used in antenna cancellation are similar to existing ideas used for creating null spots using multiple antennas. Existing methods for introducing null regions use either MIMO techniques or phased array antennas, which require hardware capable of dynamically controlling the antenna array elements. Theoretical work has suggested using MIMO relay systems to cancel out self interference [22], although this work does not provide an actual implementation of the system. Creating null spots using simple antenna positioning and its application to enable full-duplex operation are contributions of this paper.

Digital cancellation has been extensively used in many existing schemes [8, 9, 10]. ZigZag [8] uses multiple transmissions of colliding packets to decode the underlying packets. This helps with solving the hidden terminal problem, requiring  $n$  time slots to resolve collisions among  $n$  packets. Successive interference cancellation [9] decodes and then cancels strong interference signals, as long as the interference is only about 20dB stronger than the signal being received. Our digital cancellation scheme does not re-

quire decoding symbols, since the decoder has the knowledge of the transmitted symbols.

Analog network coding [10] uses access points as analog symbol repeaters which also repeat symbols of colliding packets. These repeated symbols are decoded at the respective destinations. Such a technique gives throughput gains when two flows are flowing in opposite directions through a single route. For setups such as the one in Figure 11 where the multiple flows have the same direction, analog network coding will not give any throughput gain over traditional routing unless the transmitting nodes can overhear each other. Full-duplex will work in both the setups.

Other techniques use spatial diversity to opportunistically route packets in a network [4, 6, 11]. These techniques are complementary to using wireless full-duplex links, but cannot be directly used with wormhole switching. Another work, COPE, uses XORs of packets for reducing congestion in wireless routing [12]. This technique uses a history of received packets and their sources to form and send coded packets to nodes that can decode that packet. Full-duplex, as discussed in Section 6, does not require packet history and coding for reducing congestion. Moreover, COPE's throughput performance is known to degrade in the presence of hidden terminals. Full-duplex naturally reduces hidden terminals and can sustain high throughput gains.

There are proposals for using multiple radios per node, with each radio tuned to a different channel, with one radio for transmission and the other for simultaneous reception [13, 1]. Such techniques, similar to our full-duplex systems, remove the  $1/3^{rd}$  scaling of throughput inherent in multi-hop wireless networks. However, these techniques require solving a complex channel assignment problem. Furthermore, the ability to overhear the next hop's transmission in full-duplex enables removing ACK overhead as discussed in Section 6.

Finally, full-duplexing has been suggested in existing work [18]. This work has suggested using only RF interference cancellation for achieving full-duplex. As shown in previous sections, using any single technique does not give enough cancellation to make full-duplexing feasible. This paper is the first example of a working implementation of a practical single channel wireless full-duplex system.

## 9. DISCUSSION AND CONCLUSIONS

This paper has described the design of a practical single channel wireless full-duplex system for 802.15.4. The median throughput gains achieved for a single hop wireless channel are within 8% of an ideal full-duplex system, thus showing the feasibility of designing such systems. This paper also discusses higher layer gains possible with wireless full-duplexing. The main restrictions in implementing wireless full-duplex systems are the design of wider band noise cancellation circuits and making the digital cancellation algorithm work in real time.

The paper shows that a combination of antenna cancellation, RF interference cancellation and digital interference cancellation can bring self-interference to within a few dB of the noise floor. There still is a loss of a few dB in SINR, which can lead to a difference in performance for multirate systems. Existing rate selection algorithms take two approaches, namely packet error rate based [3, 14], and signal to noise ratio based [19, 21]. Packet error rate based schemes would work directly for full-duplex radios. SNR/SINR based schemes would have to take into account the loss in SINR due to self-interference.

Wireless channels are variable in nature. We have seen that even at the short distance between the transmit and receive antennas, the channel gain can vary by a few dB over a few minutes of operation.

The noise cancellation circuit currently requires manually setting the amplitude and phase for interference cancellation. Designing adaptive algorithms to track channel variations and setting the amplitude and phase level for the noise cancelling circuit is part of future work.

An interesting future research direction is the design of a media access control (MAC) layer that can take advantage of full-duplex wireless. Such protocols can address some of the perennial problems in wireless networks such as end-to-end delay and network congestion. We believe this work provides a new research direction for the design and analysis of higher layer protocols for wireless networks.

## 10. ACKNOWLEDGMENTS

This work was supported by generous gifts from DoCoMo Capital, the National Science Foundation under grants #0831163 and #0846014, the King Abdullah University of Science and Technology (KAUST), Microsoft Research, a scholarship from the Samsung Scholarship Foundation and a Stanford Terman Fellowship. Finally, we would like to thank our shepherd, Ashutosh Sabharwal, and the anonymous reviewers for their comments.

## 11. REFERENCES

- [1] P. Bahl, A. Adya, J. Padhye, and A. Walman. Reconsidering wireless systems with multiple radios. *SIGCOMM Comput. Commun. Rev.*, 34(5):39–46, 2004.
- [2] P. Bahl, R. Chandra, T. Moscibroda, R. Murty, and M. Welsh. White space networking with wi-fi like connectivity. *SIGCOMM Comput. Commun. Rev.*, 2009.
- [3] J. Bicket. Bit-rate selection in wireless networks. Master's thesis, MIT, 2005.
- [4] S. Biswas and R. Morris. ExOR: opportunistic multi-hop routing for wireless networks. In *SIGCOMM '05: Proceedings of the 2005 conference on Applications, technologies, architectures, and protocols for computer communications*, 2005.
- [5] N. Blefari-Melazzi, A. Detti, I. Habib, A. Ordine, and S. Salsano. TCP Fairness Issues in IEEE 802.11 Networks: Problem Analysis and Solutions Based on Rate Control. *IEEE Transactions on Wireless Communications*, 6(4):1346–1355, 2007.
- [6] S. Chachulski, M. Jennings, S. Katti, and D. Katabi. Trading structure for randomness in wireless opportunistic routing. In *SIGCOMM '07: Proceedings of the 2007 conference on Applications, technologies, architectures, and protocols for computer communications*, 2007.
- [7] W. J. Dally and C. L. Seitz. The torus routing chip. *Distributed Computing*, 1(4):187–196, 1986.
- [8] S. Gollakota and D. Katabi. ZigZag decoding: combating hidden terminals in wireless networks. In *SIGCOMM '08: Proceedings of the ACM SIGCOMM 2008 conference on Data communication*, pages 159–170, New York, NY, USA, 2008. ACM.
- [9] D. Halperin, T. Anderson, and D. Wetherall. Taking the sting out of carrier sense: interference cancellation for wireless lans. In *MobiCom '08: Proceedings of the 14th ACM international conference on Mobile computing and networking*, pages 339–350, New York, NY, USA, 2008. ACM.
- [10] S. Katti, S. Gollakota, and D. Katabi. Embracing wireless interference: analog network coding. In *SIGCOMM '07: Proceedings of the 2007 conference on Applications, technologies, architectures, and protocols for computer communications*, pages 397–408, New York, NY, USA, 2007. ACM.
- [11] S. Katti and D. Katabi. Mixit: The network meets the wireless channel. In *Hotnets-VI: Proceedings of ACM Hot Topics in Networks Workshop*, 2007.
- [12] S. Katti, H. Rahul, W. Hu, D. Katabi, M. Medard, and J. Crowcroft. Xors in the air: practical wireless network coding. In *SIGCOMM '06: Proceedings of the 2006 conference on Applications, technologies, architectures, and protocols for computer communications*, pages 243–254, New York, NY, USA, 2006. ACM.
- [13] P. Kyasanur and N. H. Vaidya. Routing and link-layer protocols for multi-channel multi-interface ad hoc wireless networks. *SIGMOBILE Mob. Comput. Commun. Rev.*, 10(1):31–43, 2006.
- [14] M. Lacage, H. Manshaei, and T. Turletti. IEEE 802.11 rate adaptation: A practical approach. Institut National De Recherche en Informatique et en Automatique, 2004.
- [15] S.-B. Lee, S.-W. Tam, I. Pefkianakis, S. Lu, M. F. Chang, C. Guo, G. Reinman, C. Peng, M. Naik, L. Zhang, and J. Cong. A scalable micro wireless interconnect structure for cmps. In *MobiCom '09: Proceedings of the 15th annual international conference on Mobile computing and networking*, pages 217–228, New York, NY, USA, 2009. ACM.
- [16] D. J. Leith, P. Clifford, D. Malone, and A. Ng. TCP Fairness in 802.11e WLANs. *IEEE Communications Letters*, 9(12), 2005.
- [17] Quellan Inc. Qhx220 narrowband noise canceller ic. [http://www.quellan.com/products/qhx220\\_ic.php](http://www.quellan.com/products/qhx220_ic.php).
- [18] B. Radunovic, D. Gunawardena, P. Key, A. Proutiere, N. Singh, H. V. Balan, and G. Dejean. Rethinking indoor wireless: Low power, low frequency, full-duplex. Technical Report MSR-TR-2009-148, Microsoft Research, 2009.
- [19] H. Rahul, F. Edalat, D. Katabi, and C. G. Sodini. Frequency-aware rate adaptation and mac protocols. In *MobiCom '09: Proceedings of the 15th annual international conference on Mobile computing and networking*, pages 193–204, New York, NY, USA, 2009. ACM.
- [20] T. Schmid. Gnu radio 802.15.4 en-and decoding. [http://nesl.ee.ucla.edu/fw/thomas/thomas\\_project\\_report.pdf](http://nesl.ee.ucla.edu/fw/thomas/thomas_project_report.pdf).
- [21] M. Vutukuru, H. Balakrishnan, and K. Jamieson. Cross-layer wireless bit rate adaptation. *SIGCOMM Comput. Commun. Rev.*, 39(4):3–14, 2009.
- [22] L. Weng and R. Murch. Multi-user MIMO relay system with self-interference cancellation. pages 958–962, March 2007.

## APPENDIX

### A. ANALYSIS ON THE RECEIVED POWER AFTER ANTENNA CANCELLATION

Let the unit power baseband signal be  $x[t]$ . The signal is scaled by different transmission amplitudes  $A_1$  and  $A_2$  at the two transmit antennas. The transmitted signals undergo attenuations  $Att_1$  and  $Att_2$  and phase shifts  $\phi_1$  and  $\phi_2$  in the wireless channel before reaching the receive antenna. The received signal is then given by:

$$\frac{A_1}{Att_1} x[t] e^{j(2\pi f_c t + \phi_1)} + \frac{A_2}{Att_2} x[t] e^{j(2\pi f_c t + \phi_2)}$$

Ideally,  $\frac{A_1}{Att_1} = \frac{A_2}{Att_2}$ , but in practical systems, it would be impossible to get the amplitudes from the two transmit signals to match exactly at the receive antenna.

We let  $\frac{A_1}{Att_1} = A_{ant}$  and represent the amplitude mismatch by  $\epsilon_{ant}^A$ , thus giving  $\frac{A_2}{Att_2} = A_{ant} + \epsilon_{ant}^A$ . Further, the two transmit symbols ideally are exactly  $\pi$  out of phase from each other when they are received at the receive antenna ( $\phi_2 = \phi_1 + \pi$ ). Since the signal transmitted is not a single frequency, but rather a band of frequencies, and due to the constraints of practical systems, we take  $\phi_2 = \phi_1 + \pi + \epsilon_{ant}^\phi$ . This gives the received signal as:

$$A_{ant}x[t]e^{j(2\pi f_c t + \phi_1)} + (A_{ant} + \epsilon_{ant}^A)x[t]e^{j(2\pi f_c t + \phi_1 + \pi + \epsilon_{ant}^\phi)}$$

$$= A_{ant}x[t]e^{j2\pi f_c t}e^{j\phi_1} \left(1 - e^{j\epsilon_{ant}^\phi}\right) - \epsilon_{ant}^A x[t]e^{j(2\pi f_c t + \phi_1 + \epsilon_{ant}^\phi)}$$

The instantaneous power of any complex signal  $r[t]$  is given by  $r[t]\overline{r[t]}$  where  $\overline{r[t]}$  is the complex conjugate of the signal. Thus, the received signal power is:

$$\left\{ A_{ant}x[t]e^{j2\pi f_c t}e^{j\phi_1} \left(1 - e^{j\epsilon_{ant}^\phi}\right) - \epsilon_{ant}^A x[t]e^{j(2\pi f_c t + \phi_1 + \epsilon_{ant}^\phi)} \right\}^*$$

$$\left\{ A_{ant}\overline{x[t]}e^{-j2\pi f_c t}e^{-j\phi_1} \left(1 - e^{-j\epsilon_{ant}^\phi}\right) - \epsilon_{ant}^A \overline{x[t]}e^{-j(2\pi f_c t + \phi_1 + \epsilon_{ant}^\phi)} \right\}$$

$$= A_{ant}^2 x[t]^2 \left(2 - e^{j\epsilon_{ant}^\phi} - e^{-j\epsilon_{ant}^\phi}\right) +$$

$$A_{ant}\epsilon_{ant}^A x[t]^2 \left(2 - e^{j\epsilon_{ant}^\phi} - e^{-j\epsilon_{ant}^\phi}\right) + \left(\epsilon_{ant}^A\right)^2 |x[t]|^2$$

$$= 2A_{ant} \left(A_{ant} + \epsilon_{ant}^A\right) |x[t]|^2 \left(1 - \cos\left(\epsilon_{ant}^\phi\right)\right)$$

$$+ \left(\epsilon_{ant}^A\right)^2 |x[t]|^2$$

The phase error occurs due to a small deviation in the receiver antenna placement. The phase shift  $\phi$  depends on the distance  $d$  between the transmit and receive antennas and is given by  $\frac{2\pi d}{\lambda}$ , where  $\lambda$  is the transmission wavelength. Thus, the phase error  $\epsilon_{ant}^\phi$  can be represented as  $\frac{2\pi\epsilon_{ant}^d}{\lambda}$ , where  $\epsilon_{ant}^d$  is the error in receiver antenna placement. The received power thus becomes:

$$2A_{ant} \left(A_{ant} + \epsilon_{ant}^A\right) |x[t]|^2 \left(1 - \cos\left(\frac{2\pi\epsilon_{ant}^d}{\lambda}\right)\right)$$

$$+ \left(\epsilon_{ant}^A\right)^2 |x[t]|^2$$