



Polygonal Meshes

COS 426, Spring 2014

Princeton University

3D Object Representations



Points

- Range image
- Point cloud

Surfaces

- Polygonal mesh
- Subdivision
- Parametric
- Implicit

Solids

- Voxels
- BSP tree
- CSG
- Sweep

High-level structures

- Scene graph
- Application specific

3D Polygonal Mesh



Set of polygons representing a 2D surface embedded in 3D

Platonic Solids



Dodecahedron



Icosahedron

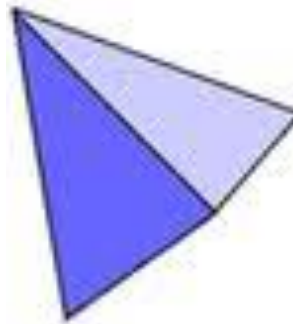

Tetrahedron

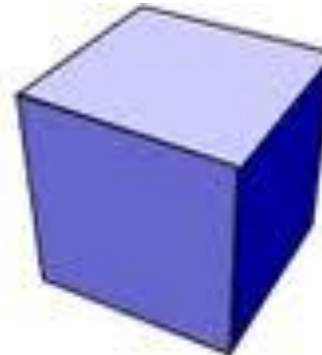

Cube



Octahedron

3D Polygonal Mesh

Set of polygons representing a 2D surface embedded in 3D

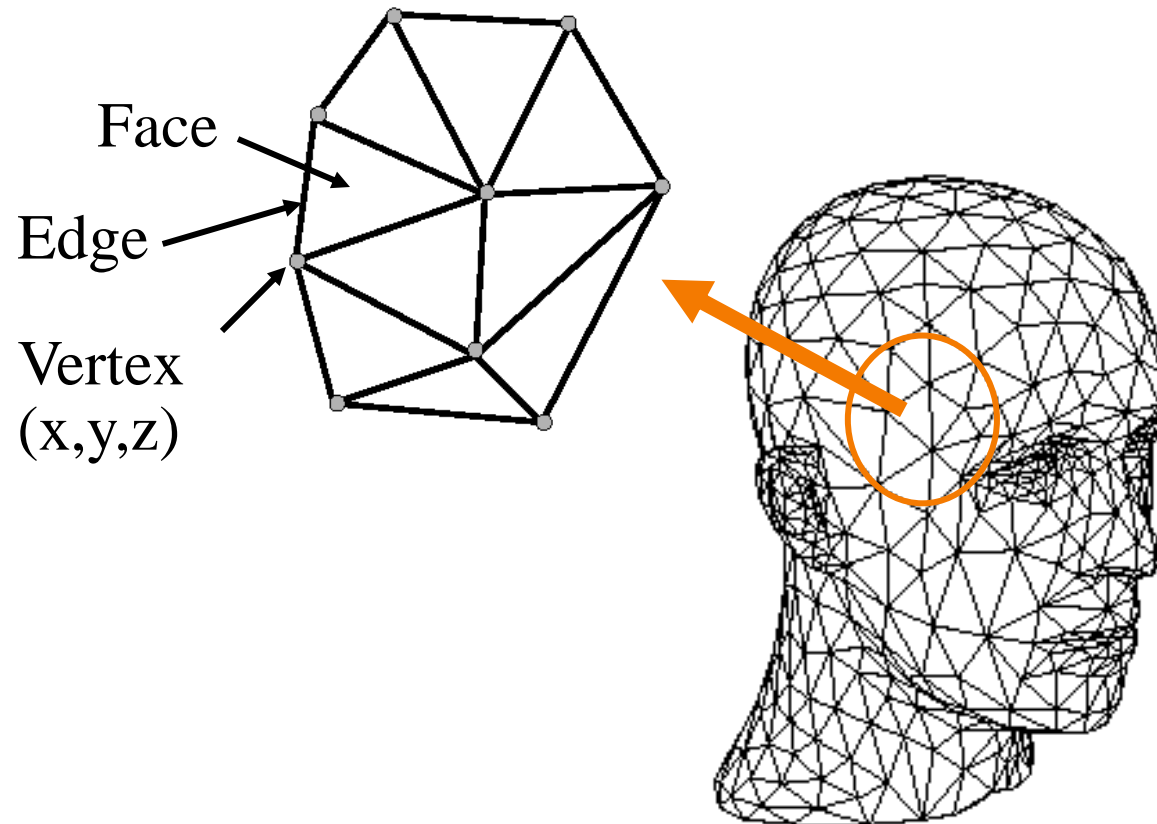

3D Polygonal Mesh

Set of polygons representing a 2D surface embedded in 3D

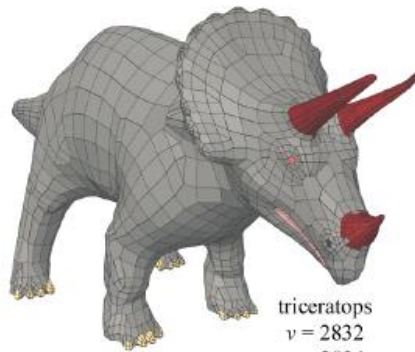

triceratops
 $v = 2832$
 $p = 2834$

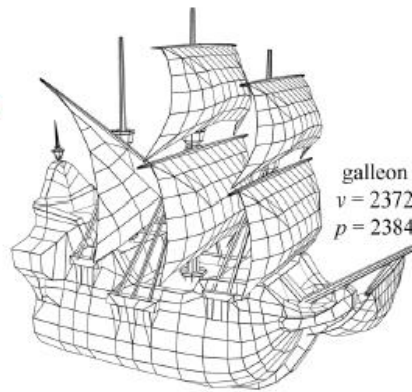

galleon
 $v = 2372$
 $p = 2384$

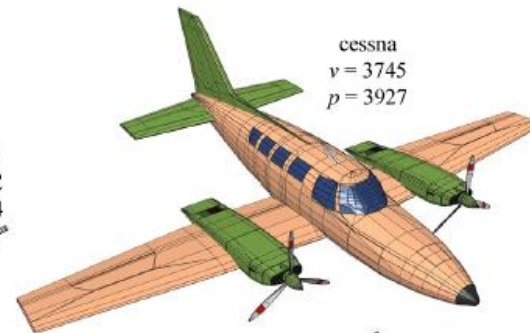

cessna
 $v = 3745$
 $p = 3927$

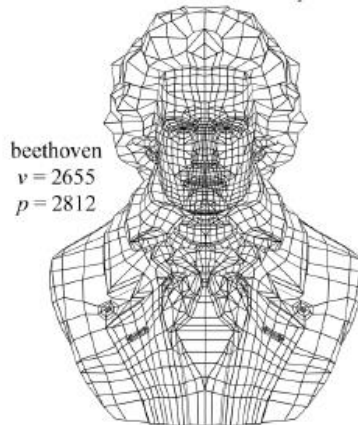

beethoven
 $v = 2655$
 $p = 2812$

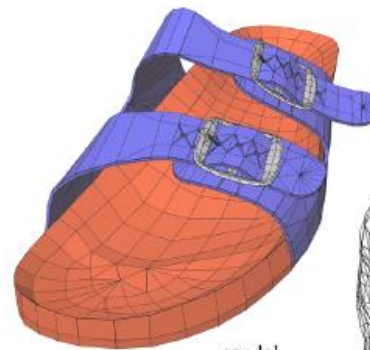

sandal
 $v = 2636$
 $p = 2953$

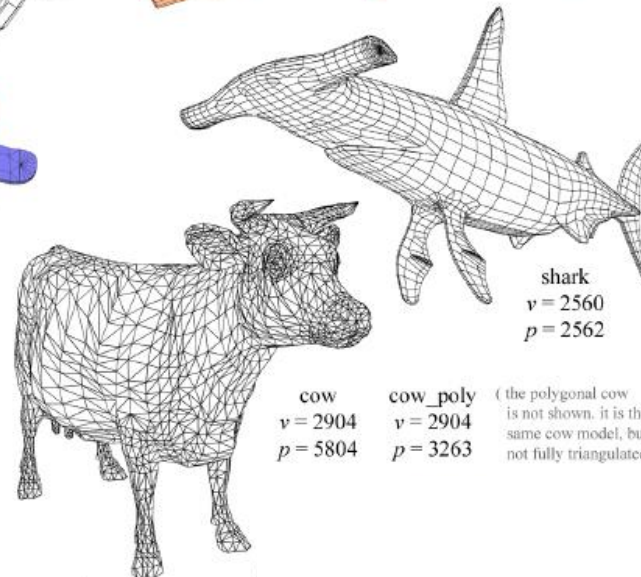

cow
 $v = 2904$
 $p = 5804$

cow_poly
 $v = 2904$
 $p = 3263$

(the polygonal cow is not shown, it is the same cow model, but not fully triangulated)

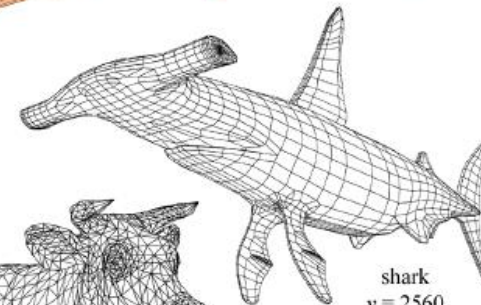

shark
 $v = 2560$
 $p = 2562$

3D Polygonal Meshes

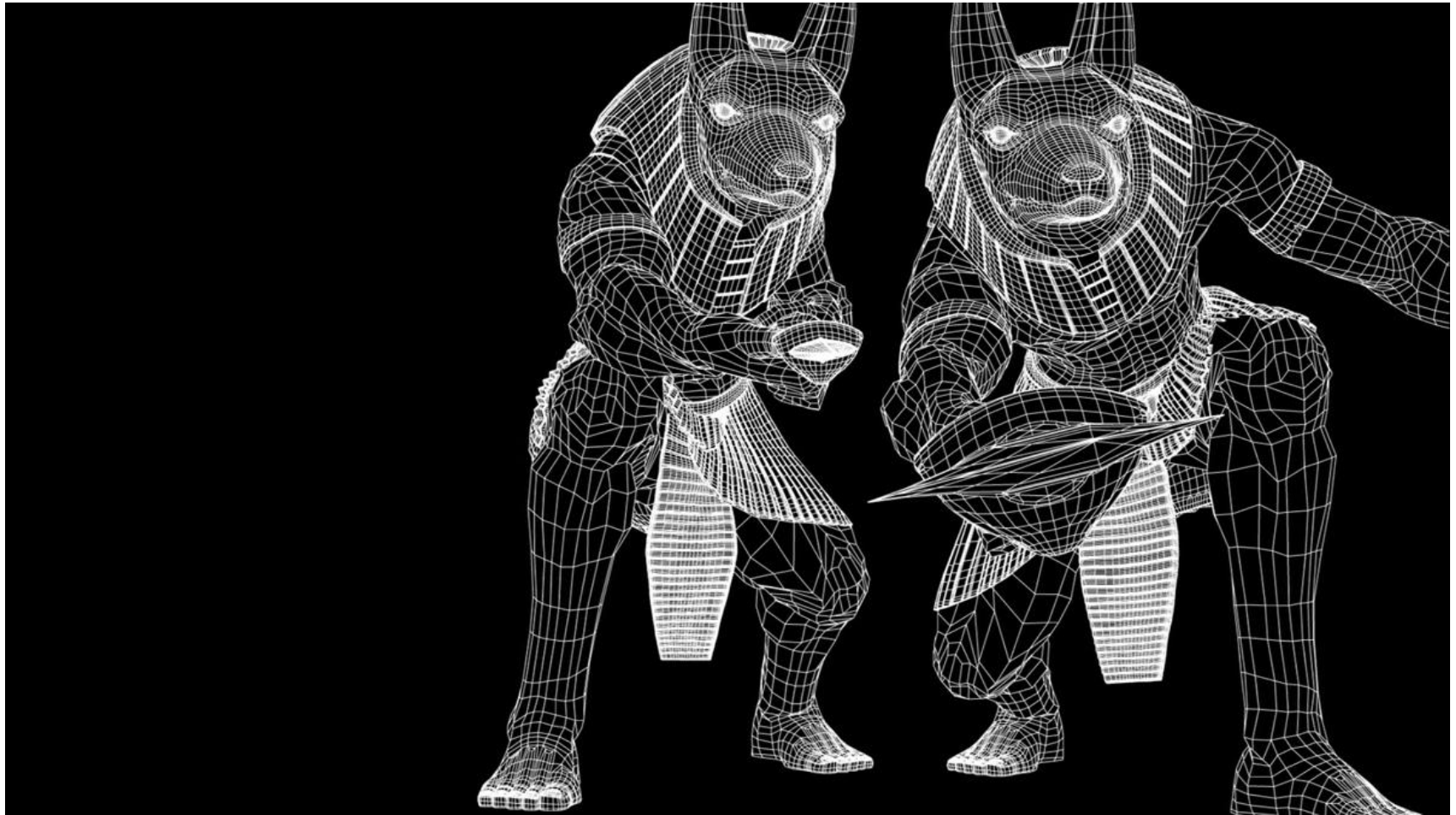

http://www.fxguide.com/featured/Comic_Horrors_Rocks_Statures_and_VanDyke/

3D Polygonal Meshes



Why are they of interest?

- Simple, common representation
- Rendering with hardware support
- Output of many acquisition tools
- Input to many simulation/analysis tools

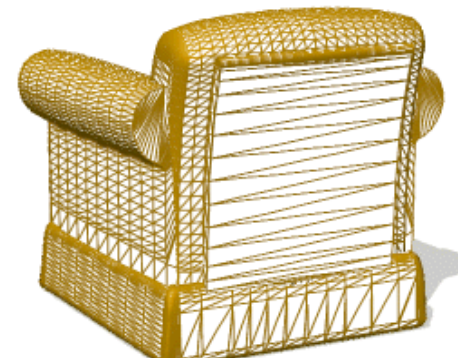

3D Polygonal Meshes



Properties

- ? Efficient display
- ? Easy acquisition
- ? Accurate
- ? Concise
- ? Intuitive editing
- ? Efficient editing
- ? Efficient intersections
- ? Guaranteed validity
- ? Guaranteed smoothness
- ? etc.

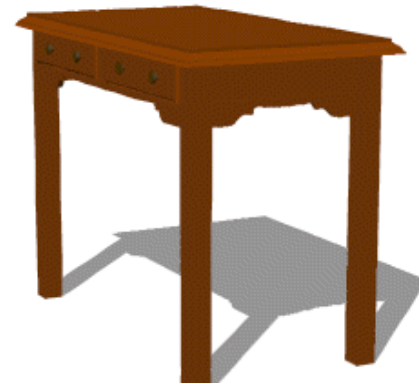
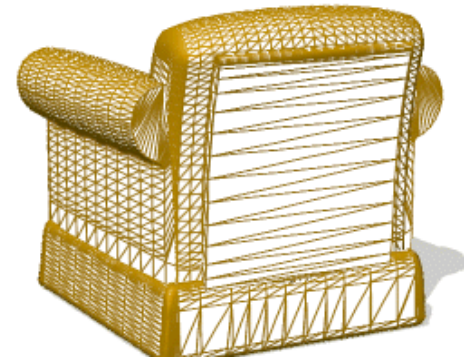
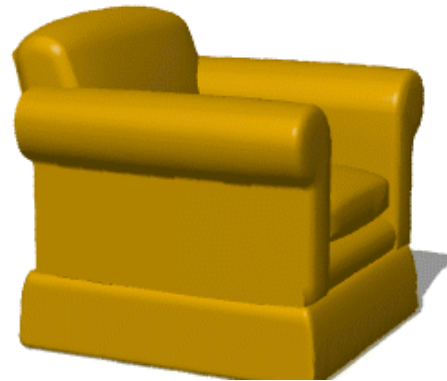

Outline



Acquisition ←

Processing

Representation

Polygonal Mesh Acquisition



Interactive modeling

- Polygon editors
- Interchange formats

Scanners

- Laser range scanners
- Geological survey
- CAT, MRI, etc. (isosurfaces)

Simulations

- Physical processes

Polygonal Mesh Acquisition



Interactive modeling

- Polygon editors
- Interchange formats

Scanners

- Laser range scanners
- Geological survey

Simulations

- Physical processes

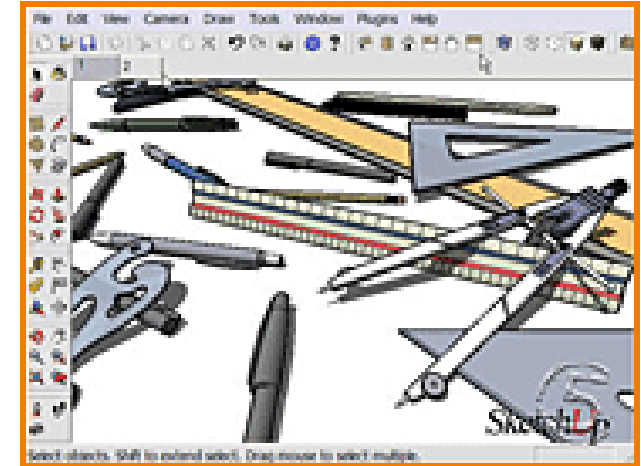

Sketchup

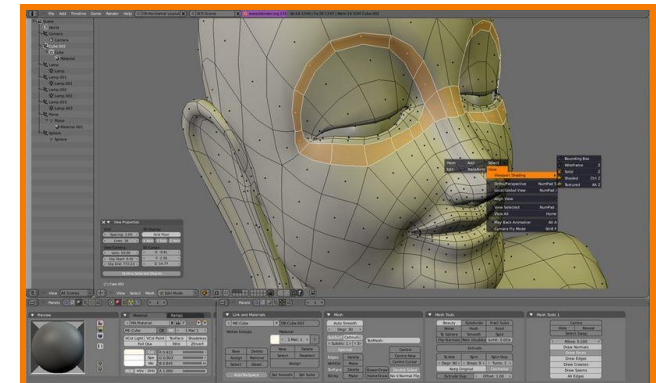

Blender

Polygonal Mesh Acquisition



Interactive modeling

- Polygon editors
- Interchange formats



Scanners

- Laser range scanners
- Geological survey



Simulations

- Physical processes



Polygonal Mesh Acquisition



Interactive modeling

- Polygon editors
- Interchange formats

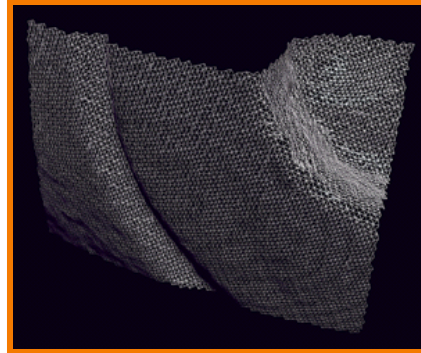

Scanners

- Laser range scanners
- Geological survey

Simulations

- Physical processes



Digital Michelangelo Project
Stanford

Polygonal Mesh Acquisition



Interactive modeling

- Polygon editors
- Interchange formats

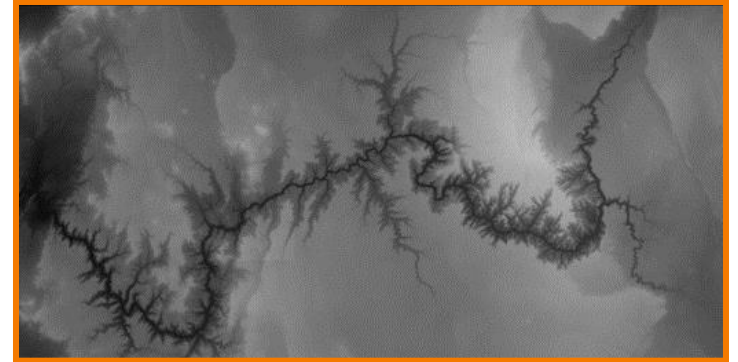

Scanners

- Laser range scanners
- Geological survey

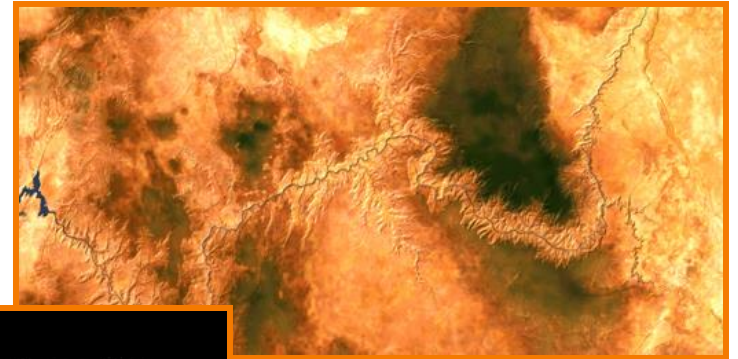

Simulations

- Physical processes

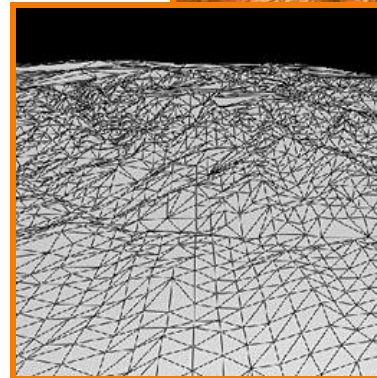

Large Geometric
Model Repository
Georgia Tech

Polygonal Mesh Acquisition



Interactive modeling

- Polygon editors
- Interchange formats

Scanners

- Laser range scanners
- **Geological survey**

Simulations

- Physical processes

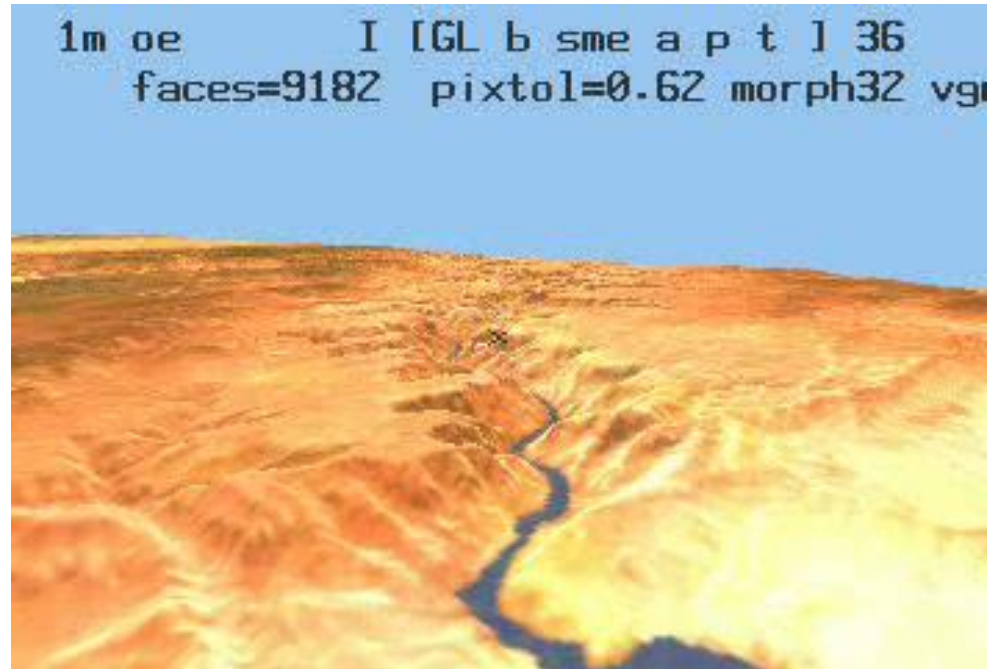

Polygonal Mesh Acquisition



Interactive modeling

- Polygon editors
- Interchange formats

Scanners

- Laser range scanners
- Geological survey

Simulations

- Physical processes

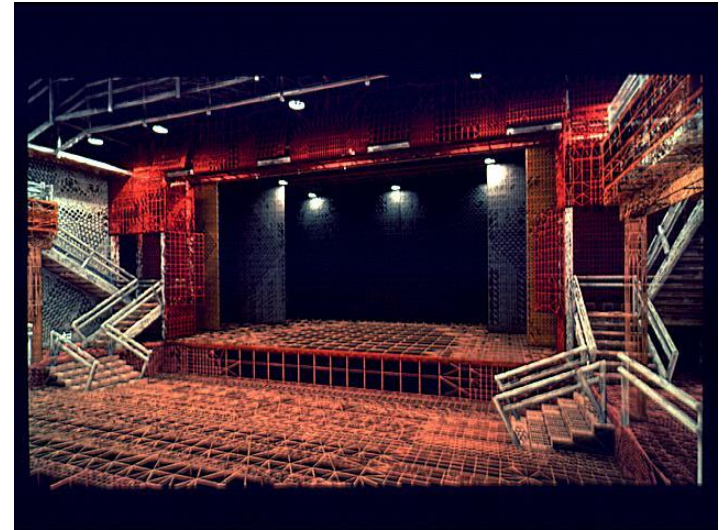

SGI

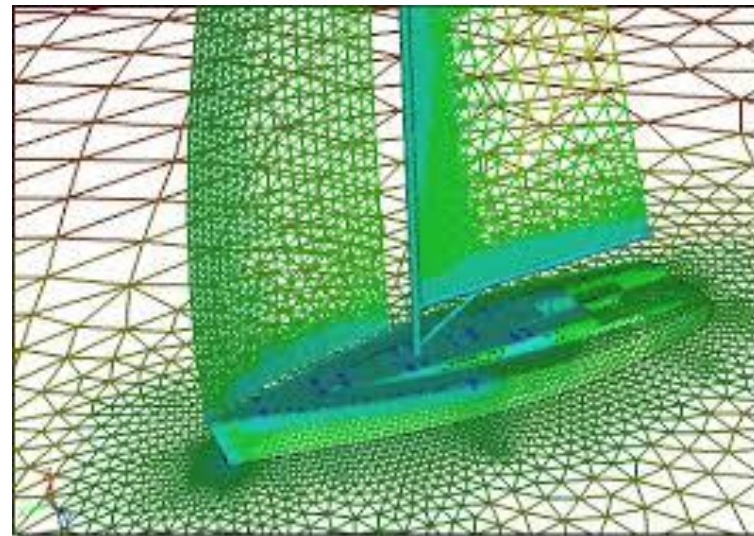

sym scape

Outline



Acquisition

Processing ←

Representation

Polygonal Mesh Processing



Analysis

- Normals
- Curvature

Warps

- Rotate
- Deform

Filters

- Smooth
- Sharpen
- Truncate
- Bevel

Polygonal Mesh Processing



Analysis ←

- Normals
- Curvature

Warps

- Rotate
- Deform

Filters

- Smooth
- Sharpen
- Truncate
- Bevel

Polygonal Mesh Processing



Analysis

- Normals
- Curvature

Warps

- Rotate
- Deform

Filters

- Smooth
- Sharpen
- Truncate
- Bevel

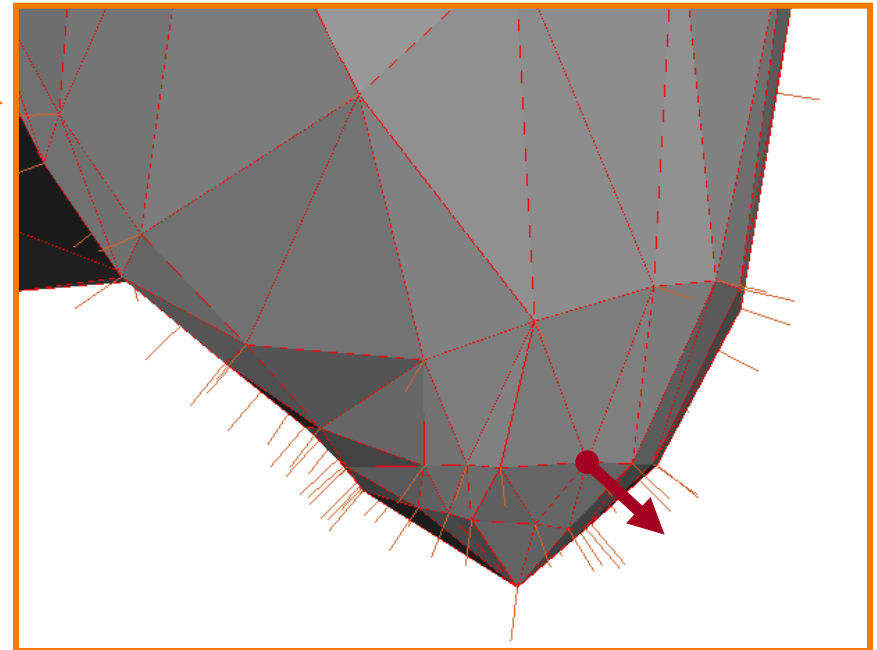
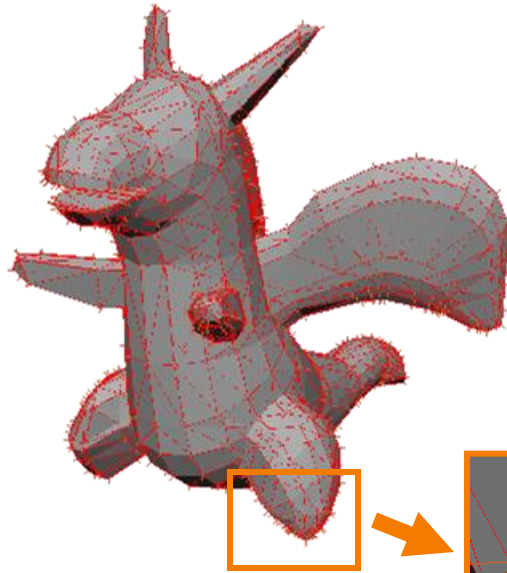

Polygonal Mesh Processing



Analysis

- Normals
- Curvature



Warps

- Rotate
- Deform

Filters

- Smooth
- Sharpen
- Truncate
- Bevel

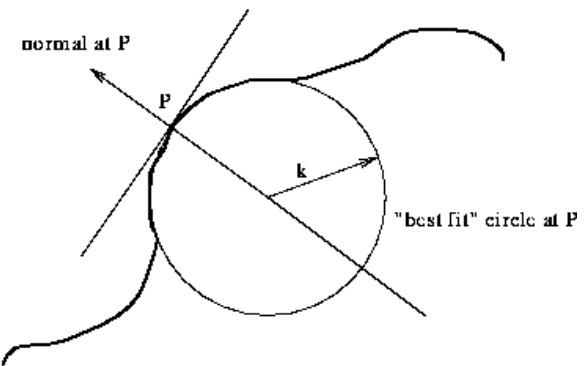

Figure 32: curvature of curve at P is $1/k$

Polygonal Mesh Processing



Analysis

- Normals
- Curvature

Warps ←

- Rotate
- Deform

Filters

- Smooth
- Sharpen
- Truncate
- Bevel

Polygonal Mesh Processing

Analysis

- Normals
- Curvature

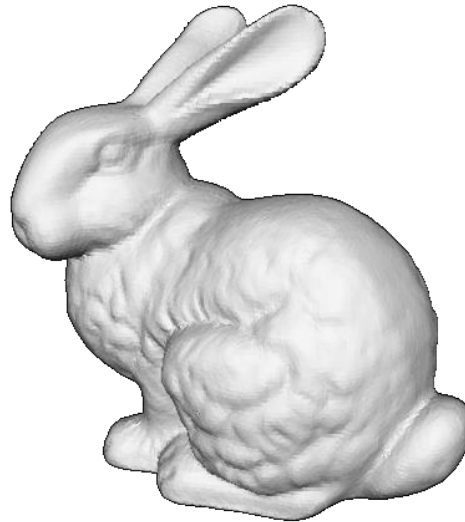

Warps

- Rotate
- Deform

Filters

- Smooth
- Sharpen
- Truncate
- Bevel

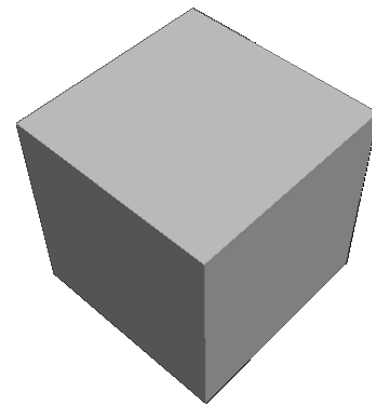
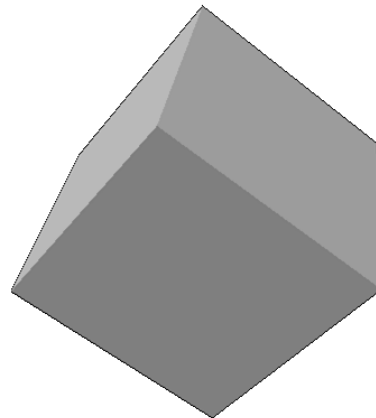

Polygonal Mesh Processing



Analysis

- Normals
- Curvature

Warps

- Rotate
- Deform

Filters

- Smooth
- Sharpen
- Truncate
- Bevel

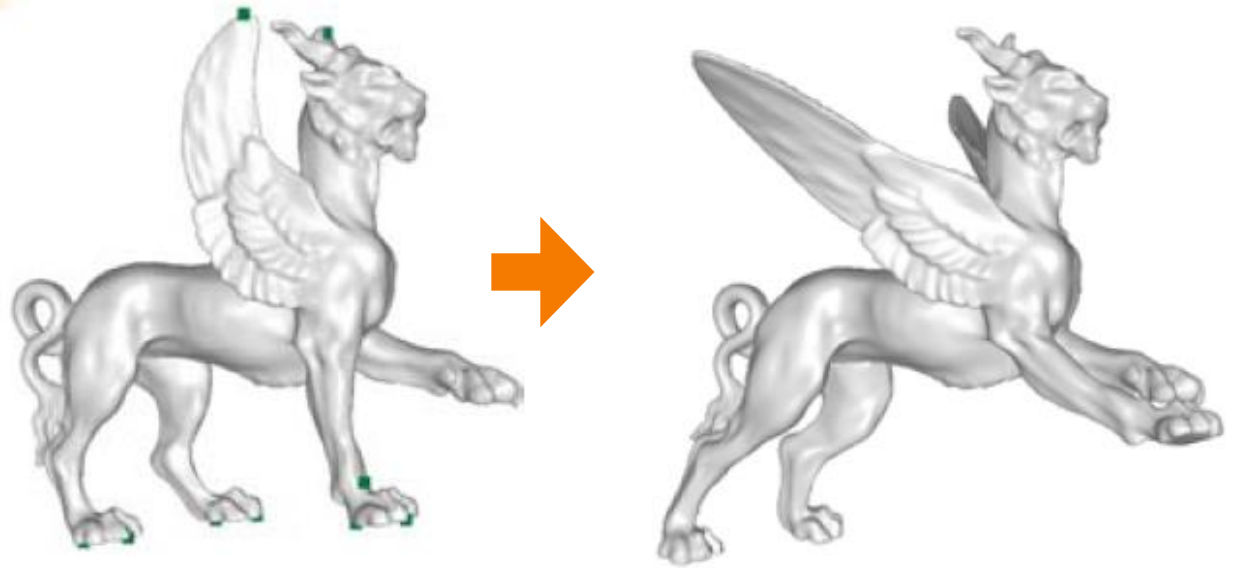

Polygonal Mesh Processing



Analysis

- Normals
- Curvature

Warps

- Rotate
- Deform

Filters

- Smooth
- Sharpen
- Truncate
- Bevel

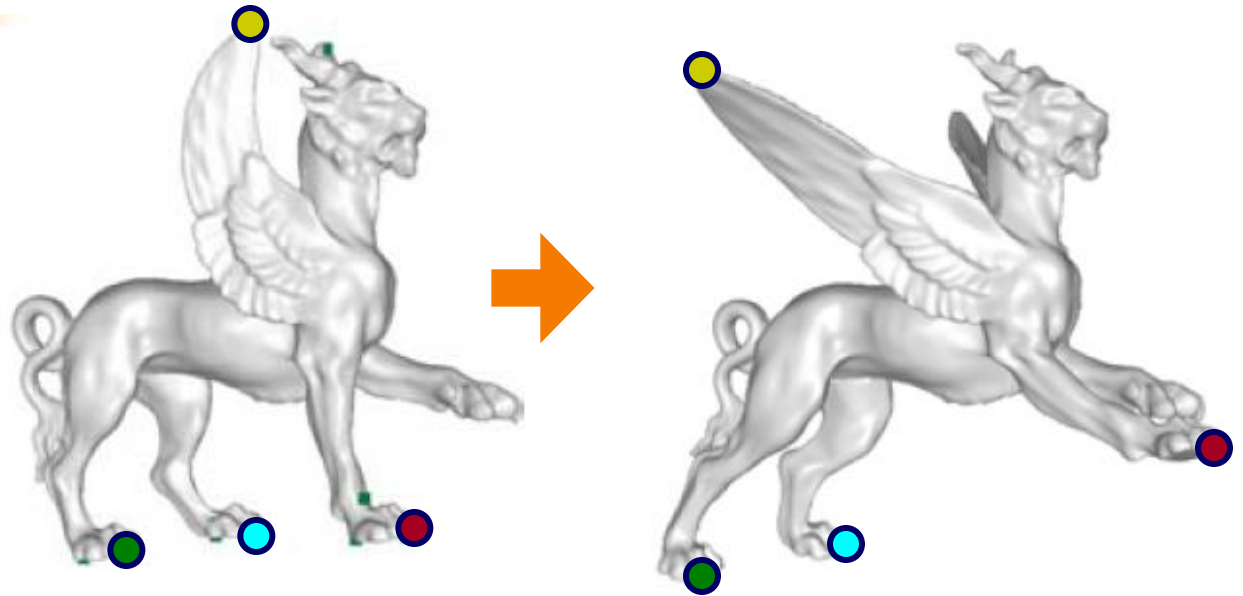

Polygonal Mesh Processing



Analysis

- Normals
- Curvature

Warps

- Rotate
- Deform

Filters ←

- Smooth
- Sharpen
- Truncate
- Bevel

Polygonal Mesh Processing



Analysis

- Normals
- Curvature

Warps

- Rotate
- Deform

Filters

- Smooth
- Sharpen
- Truncate
- Bevel



Thouis “Ray” Jones

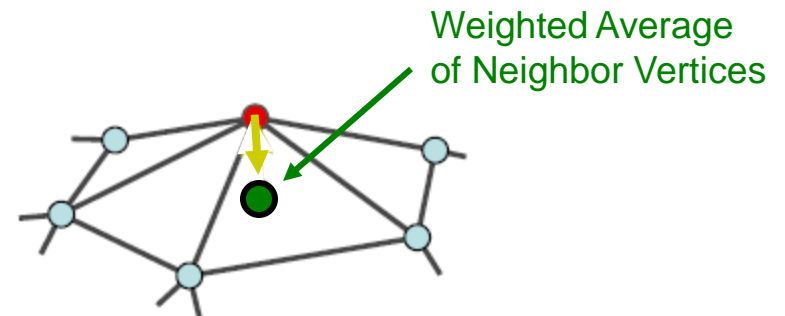

Olga Sorkine

Polygonal Mesh Processing



Analysis

- Normals
- Curvature

Warps

- Rotate
- Deform

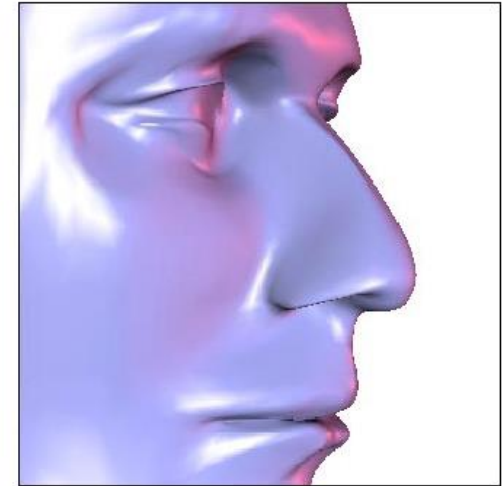
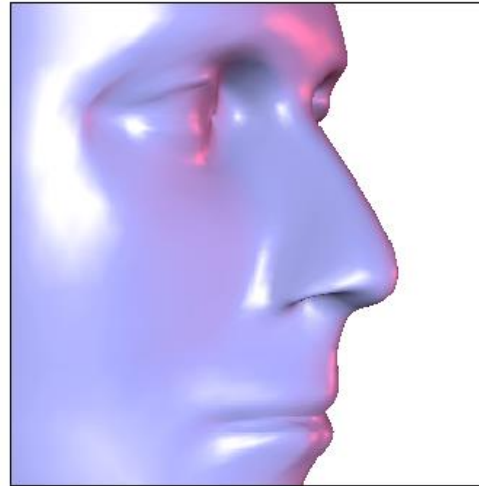

Desbrun

Filters

- Smooth
- **Sharpen**
- Truncate
- Bevel

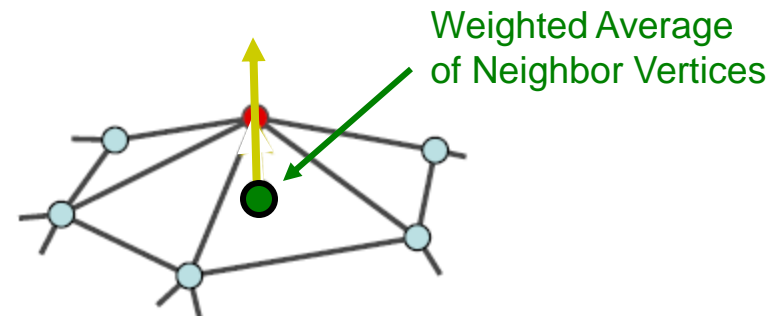

Olga Sorkine

Polygonal Mesh Processing



Analysis

- Normals
- Curvature

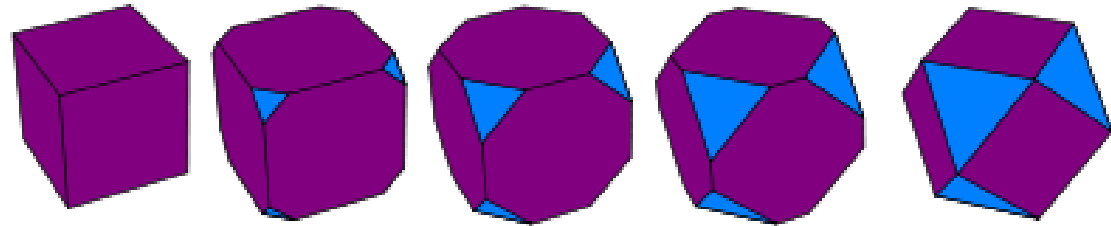

Cube $\frac{1}{4}$ truncated uniform truncated $\frac{3}{4}$ truncated Rectified

Warps

- Rotate
- Deform

Filters

- Smooth
- Sharpen
- **Truncate**
- Bevel

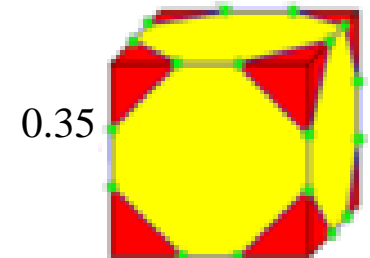
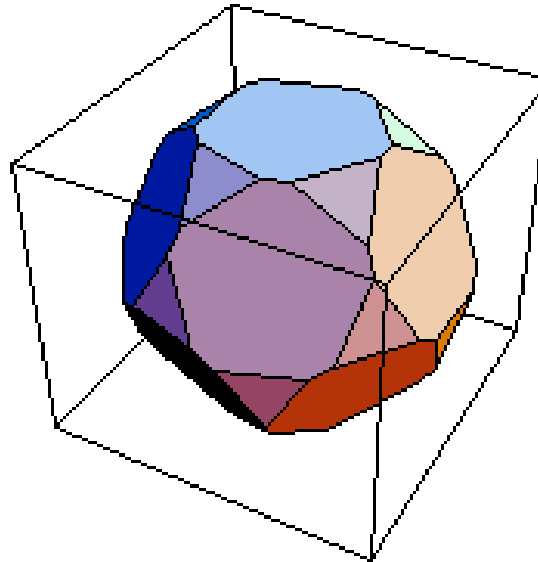

Conway

Polygonal Mesh Processing



Analysis

- Normals
- Curvature

Warps

- Rotate
- Deform

Filters

- Smooth
- Sharpen
- **Truncate**
- Bevel

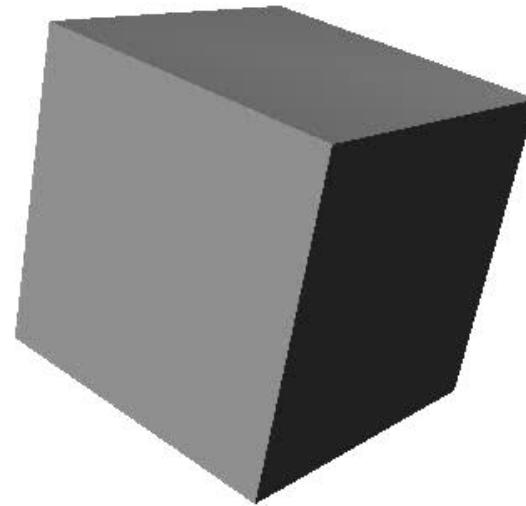



Polygonal Mesh Processing

Analysis

- Normals
- Curvature



Warps

- Rotate
- Deform

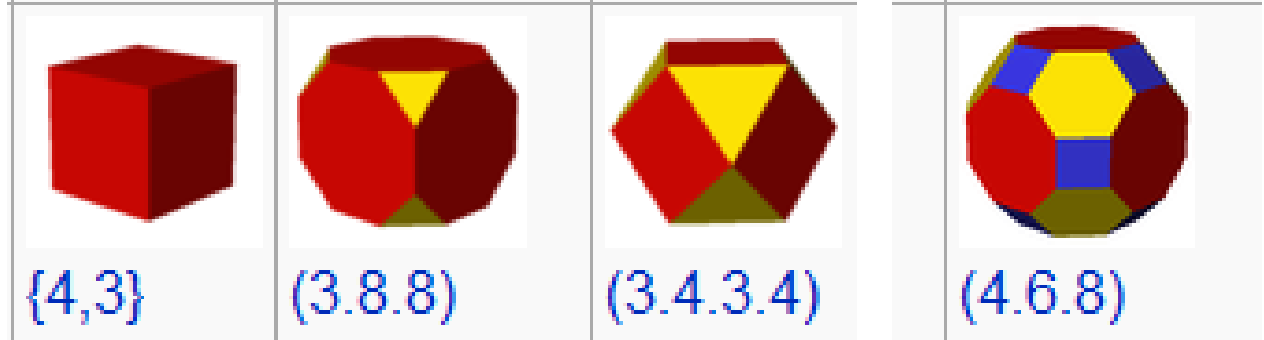

Filters

- Smooth
- Sharpen
- **Truncate**
- Bevel

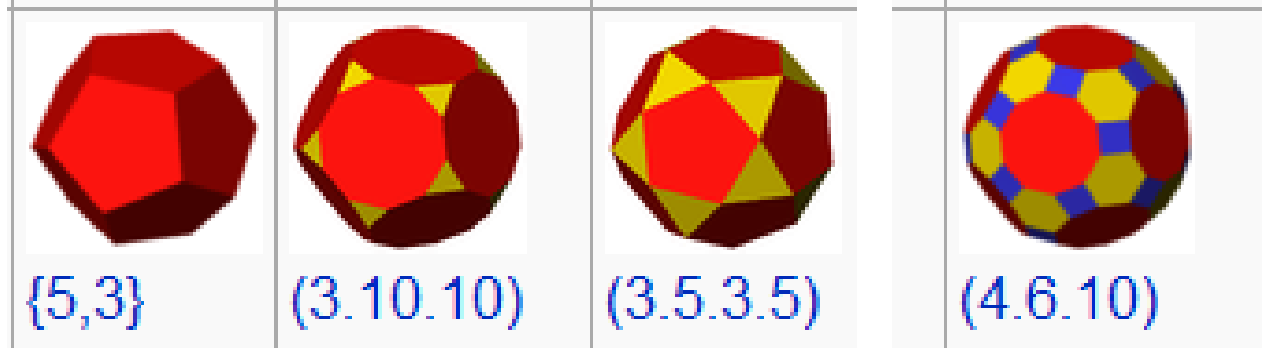



Polygonal Mesh Processing

Analysis

- Normals
- Curvature

Warps

- Rotate
- Deform

Filters

- Smooth
- Sharpen
- **Truncate**
- Bevel

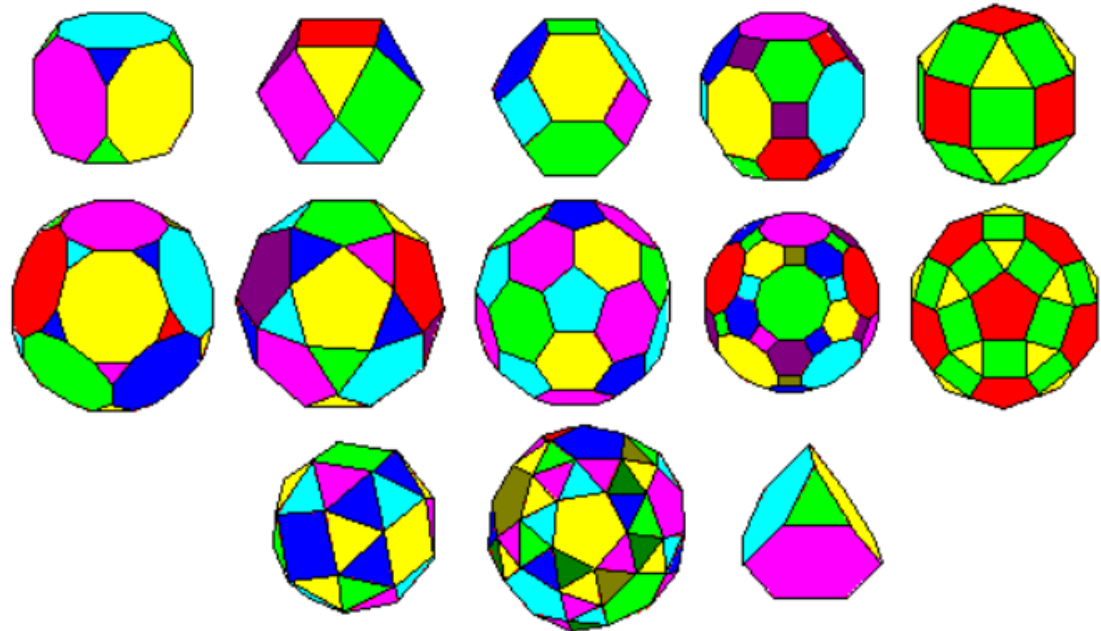

Archimedean Polyhedra

<http://www.uwgb.edu/dutchs/symmetry/archpol.htm>

Polygonal Mesh Processing



Analysis

- Normal
- Curvature

Warp

- Remesh
- Deform

Filter

- Smooth
- Sharpen
- Triangulate

- Bevel

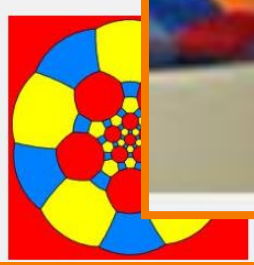
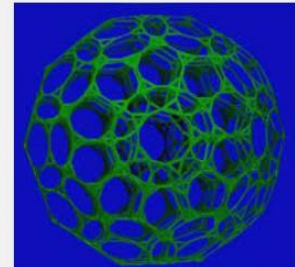
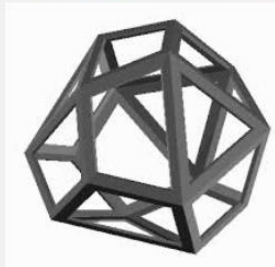

Carlo Séquin

Polygonal Mesh Processing



Wikipedia

Analysis

- Normals
- Curvature

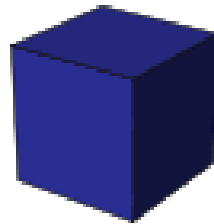

(regular polyhedron)
Cube

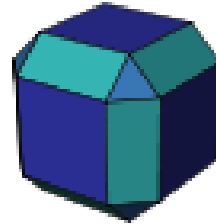

$\frac{1}{2}$ cantellated
(beveled cube)

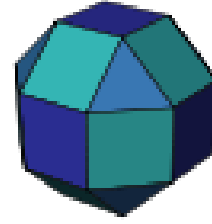

Uniform cantellation
Rhombicuboctahedron

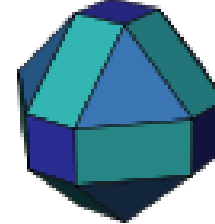

$\frac{1}{2}$ cantellated
(beveled octahedron)

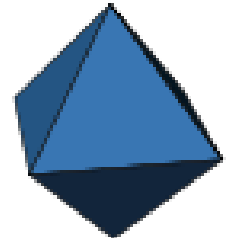

(regular dual)
Octahedron

Warps

- Rotate
- Deform

Filters

- Smooth
- Sharpen
- Truncate
- Bevel

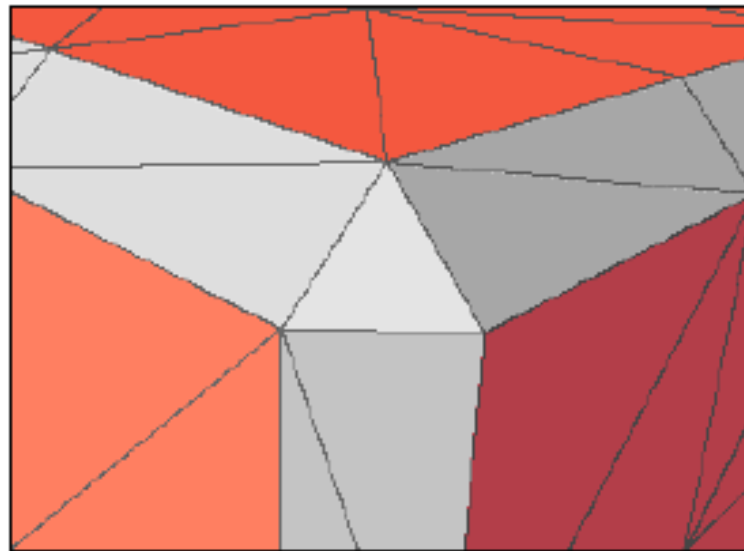

Jarek Rossignac

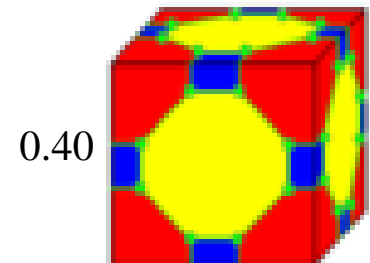

Conway

Polygonal Mesh Processing



Analysis

- Normals
- Curvature

Warps

- Rotate
- Deform

Filters

- Smooth
- Sharpen
- Truncate
- Bevel



Polygonal Mesh Processing



Analysis

- Normals
- Curvature

Warps

- Rotate
- Deform

Filters

- Smooth
- Sharpen
- Truncate
- Bevel

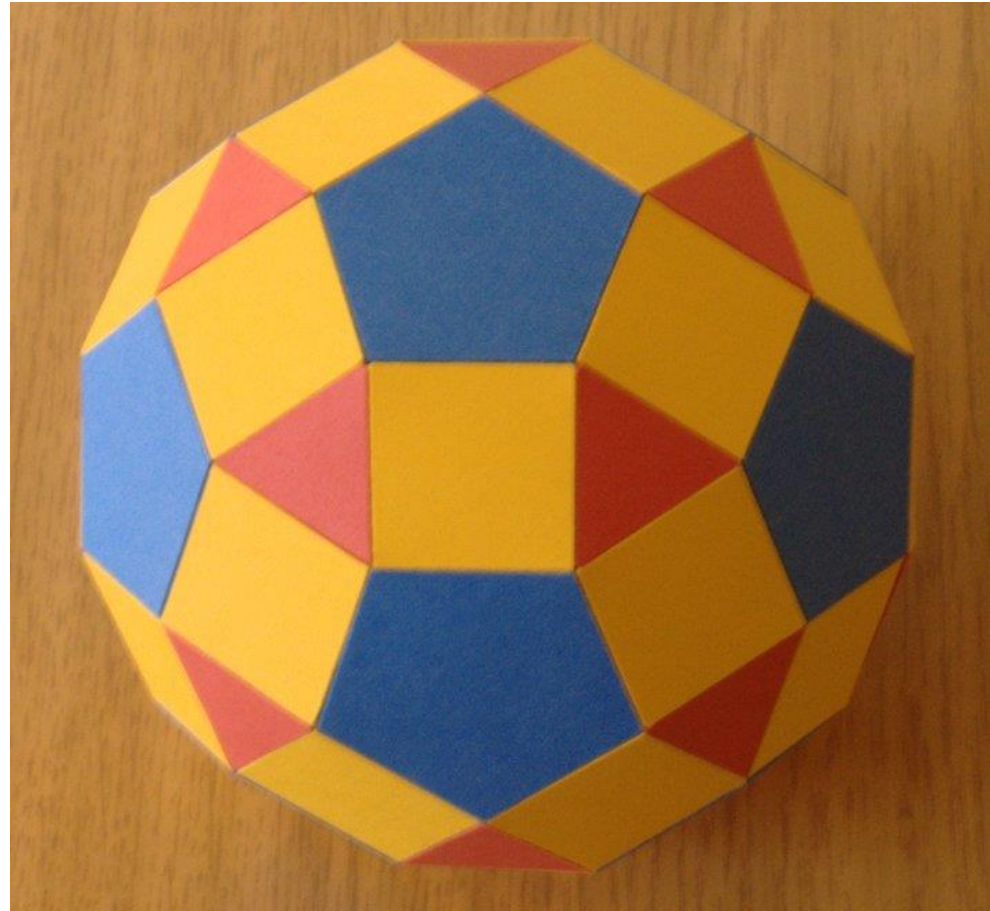

Polygonal Mesh Processing



Remeshing

- Subdivide
- Resample
- Simplify

Topological fixup

- Fill holes
- Fix self-intersections

Boolean operations

- Crop
- Subtract



Polygonal Mesh Processing

Remeshing ←

- Subdivide
- Resample
- Simplify

Topological fixup

- Fill holes
- Fix self-intersections

Boolean operations

- Crop
- Subtract

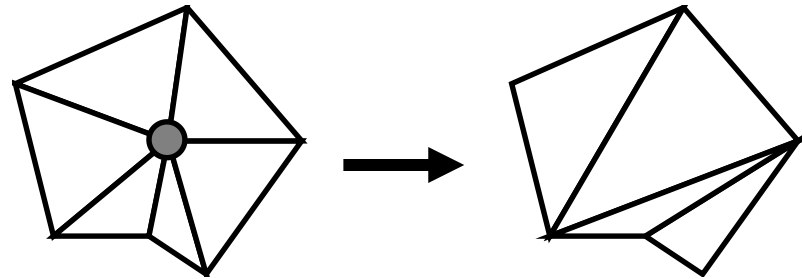

Remove Vertex

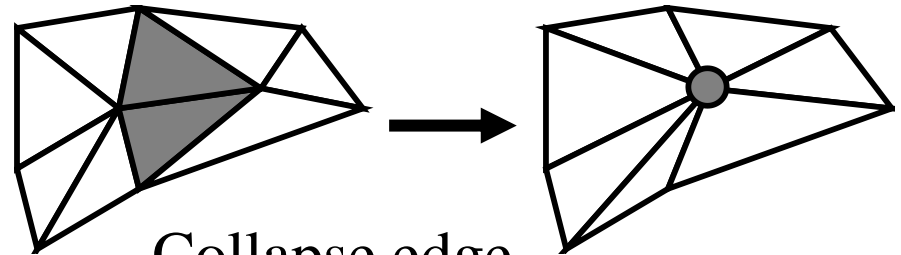

Collapse edge

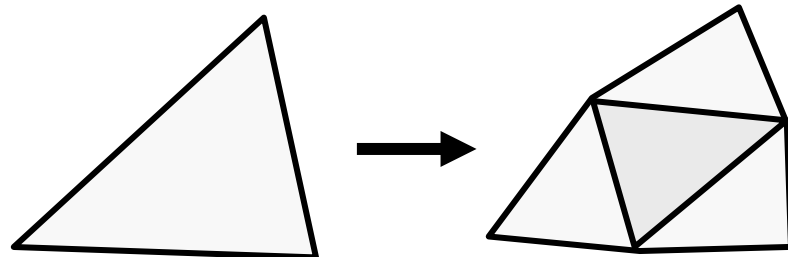

Subdivide face

Polygonal Mesh Processing



Remeshing

- **Subdivide**
- Resample
- Simplify

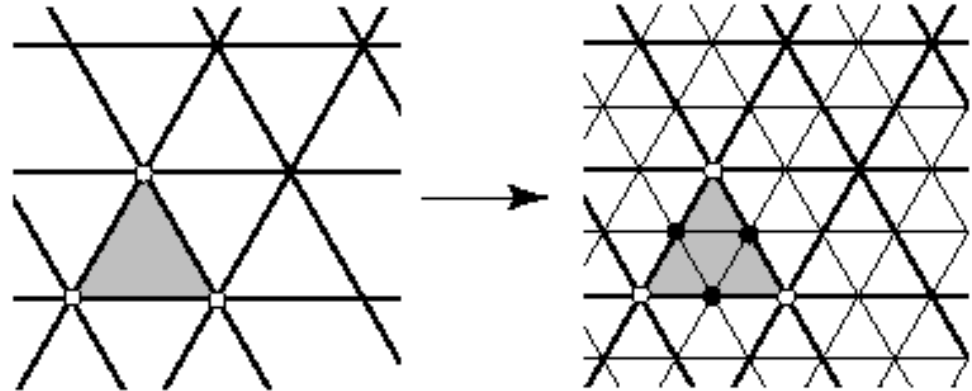

Topological fixup

- Fill holes
- Fix self-intersections

Boolean operations

- Crop
- Subtract

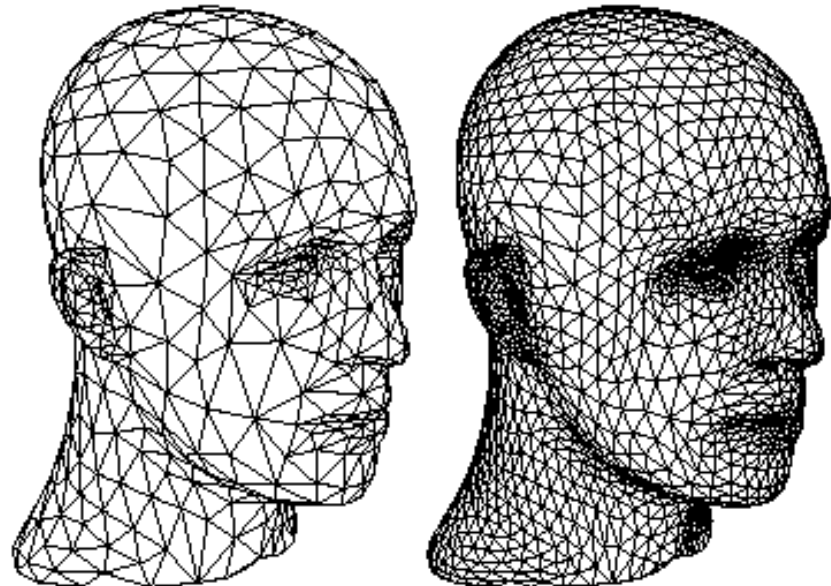

Polygonal Mesh Processing

Remeshing

- **Subdivide**
- Resample
- Simplify

Topological fixup

- Fill holes
- Fix self-intersections

Boolean operations

- Crop
- Subtract

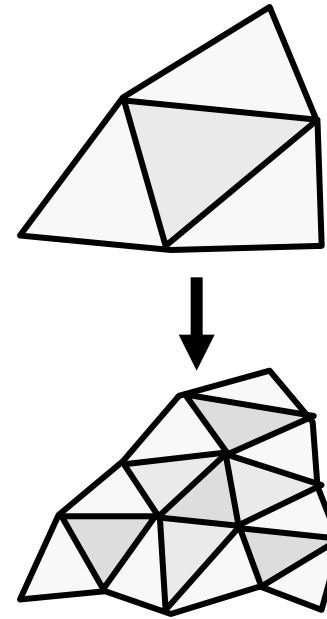

Fractal Landscape



*Dirk Balfanz, Igor Guskov,
Sanjeev Kumar, & Rudro Samanta,*

Polygonal Mesh Processing



Remeshing

- Subdivide
- Resample
- Simplify

Topological fixup

- Fill holes
- Fix self-intersections

Boolean operations

- Crop
- Subtract

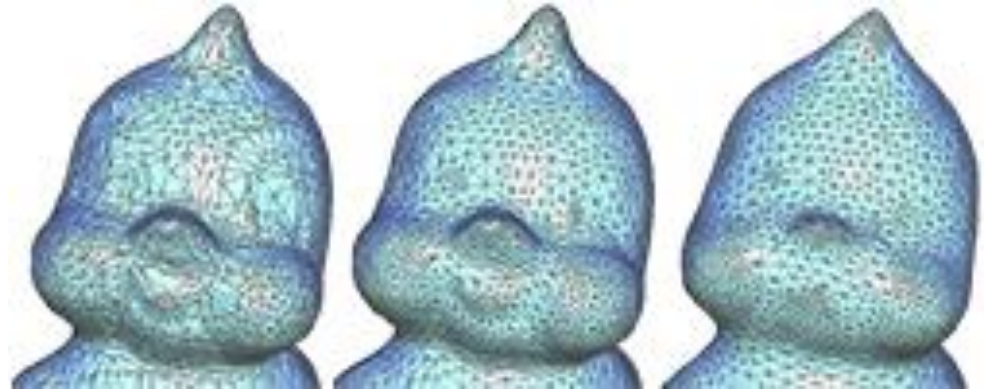

Original

Resampled

- more uniform distribution
- triangles with nicer aspect

Polygonal Mesh Processing



Remeshing

- Subdivide
- Resample
- Simplify

Topological fixup

- Fill holes
- Fix self-intersections

Boolean operations

- Crop
- Subtract



Polygonal Mesh Processing



Remeshing

- Subdivide
- Resample
- Simplify

Topological fixup ←

- Fill holes
- Fix self-intersections

Boolean operations

- Crop
- Subtract

Polygonal Mesh Processing



Remeshing

- Subdivide
- Resample
- Simplify

Topological fixup

- **Fill holes**
- Fix self-intersections

Boolean operations

- Crop
- Subtract

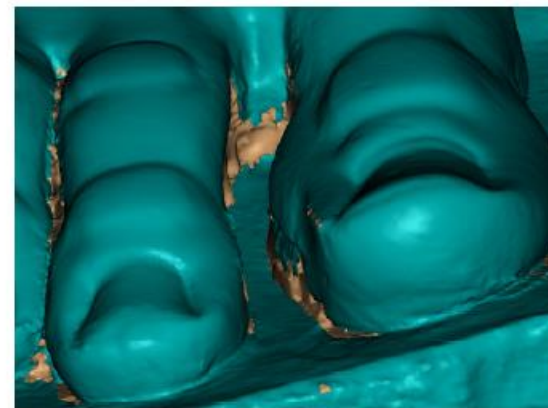
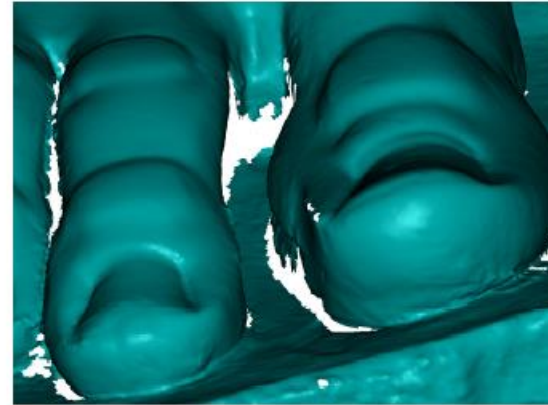

Polygonal Mesh Processing



Remeshing

- Subdivide
- Resample
- Simplify

Topological fixup

- Fill holes
- **Fix self-intersections**

Boolean operations

- Crop
- Subtract

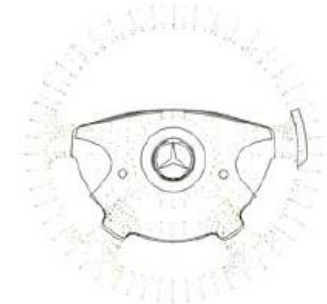
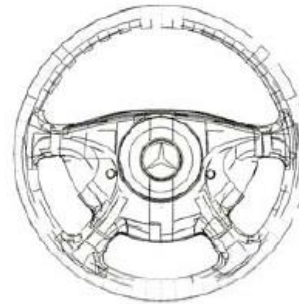
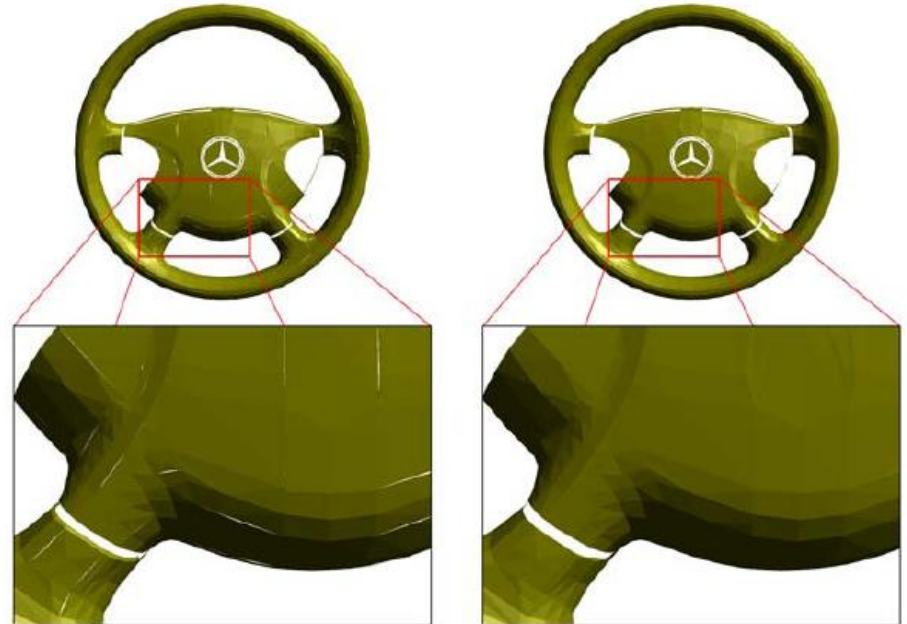

Polygonal Mesh Processing



Remeshing

- Subdivide
- Resample
- Simplify

Topological fixup

- Fill holes
- Fix self-intersections

Boolean operations ←

- Crop
- Subtract

Polygonal Mesh Processing



Remeshing

- Subdivide
- Resample
- Simplify

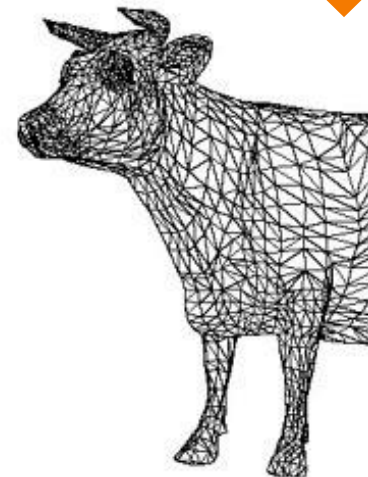
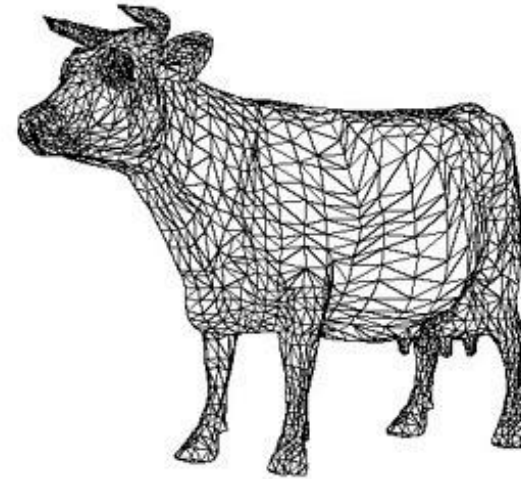

Topological fixup

- Fill holes
- Fix self-intersections

Boolean operations

- Crop
- Subtract

Polygonal Mesh Processing



Remeshing

- Subdivide
- Resample
- Simplify

Topological fixup

- Fill holes
- Fix self-intersections

Boolean operations

- Crop
- Subtract

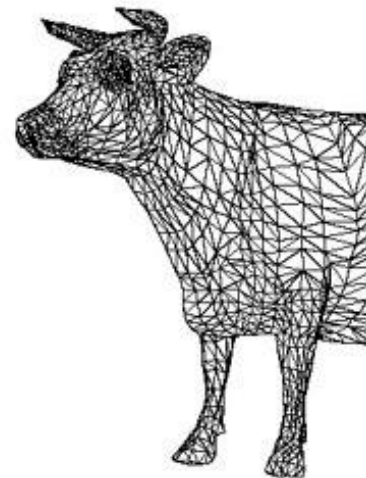
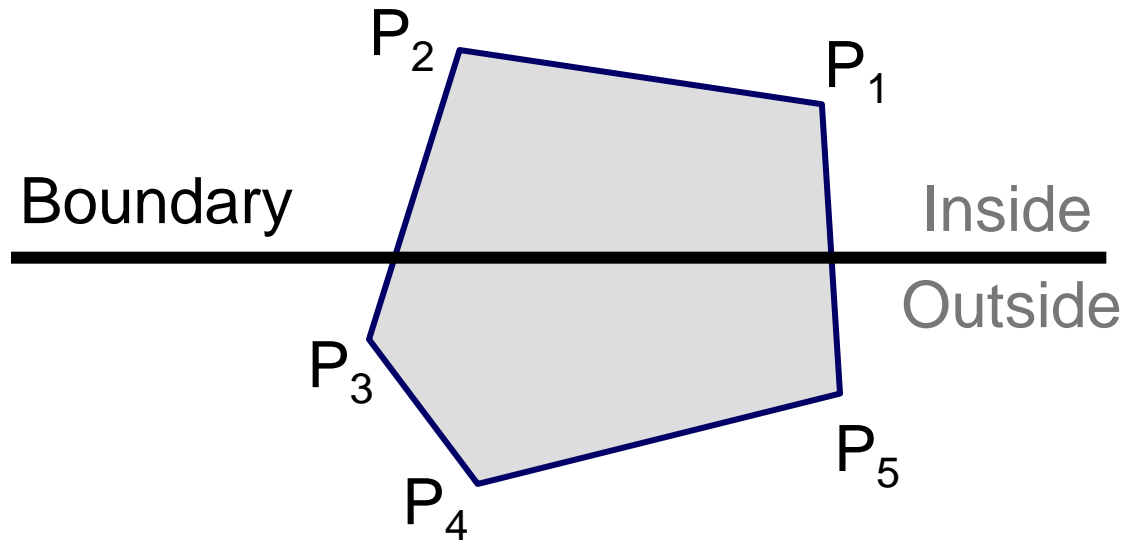

Polygonal Mesh Processing



Remeshing

- Subdivide
- Resample
- Simplify

Topological fixup

- Fill holes
- Fix self-intersections

Boolean operations

- Crop
- Subtract

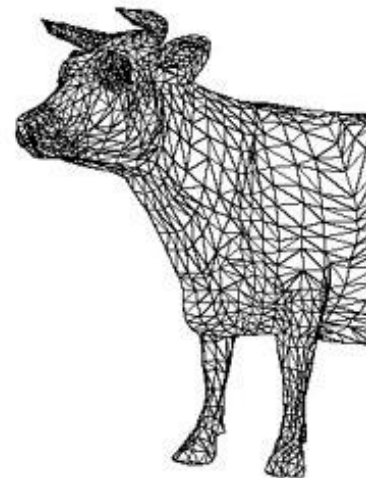
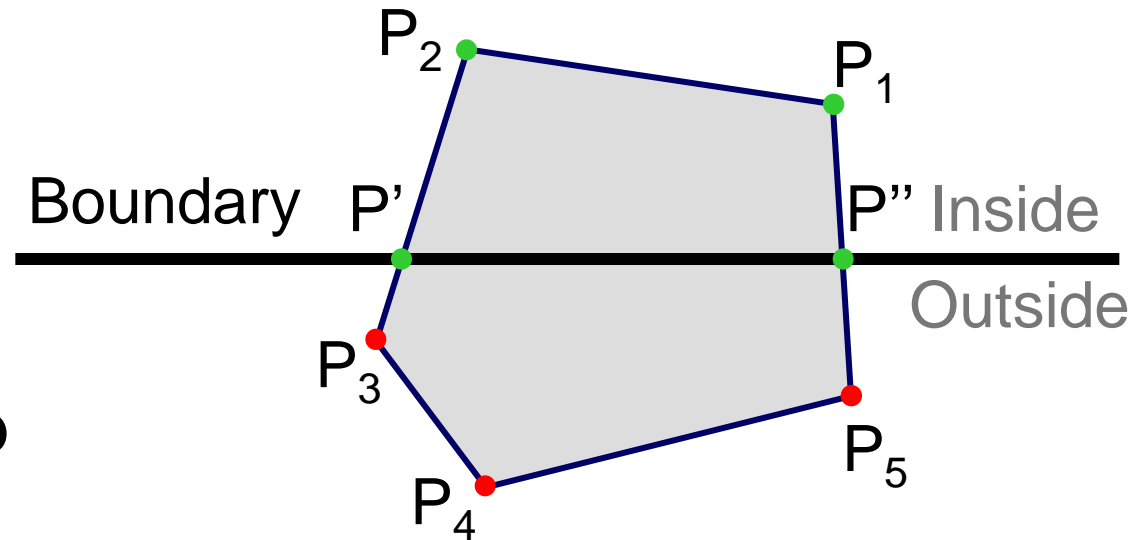

Polygonal Mesh Processing



Remeshing

- Subdivide
- Resample
- Simplify

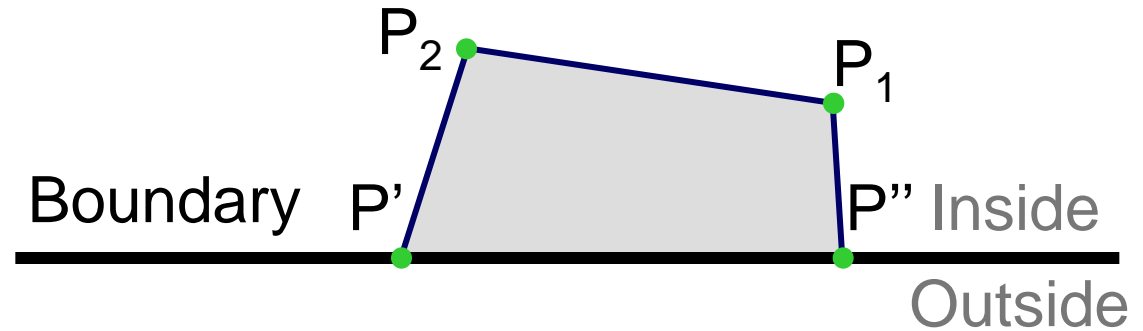

Topological fixup

- Fill holes
- Fix self-intersections

Boolean operations

- Crop
- Subtract

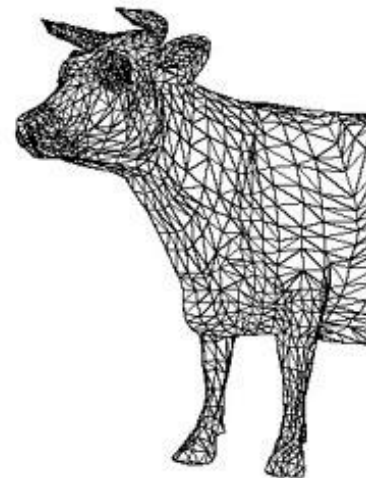

Polygonal Mesh Processing

Remeshing

- Subdivide
- Resample
- Simplify

Topological fixup

- Fill holes
- Fix self-intersections

Boolean operations

- Crop
- Subtract

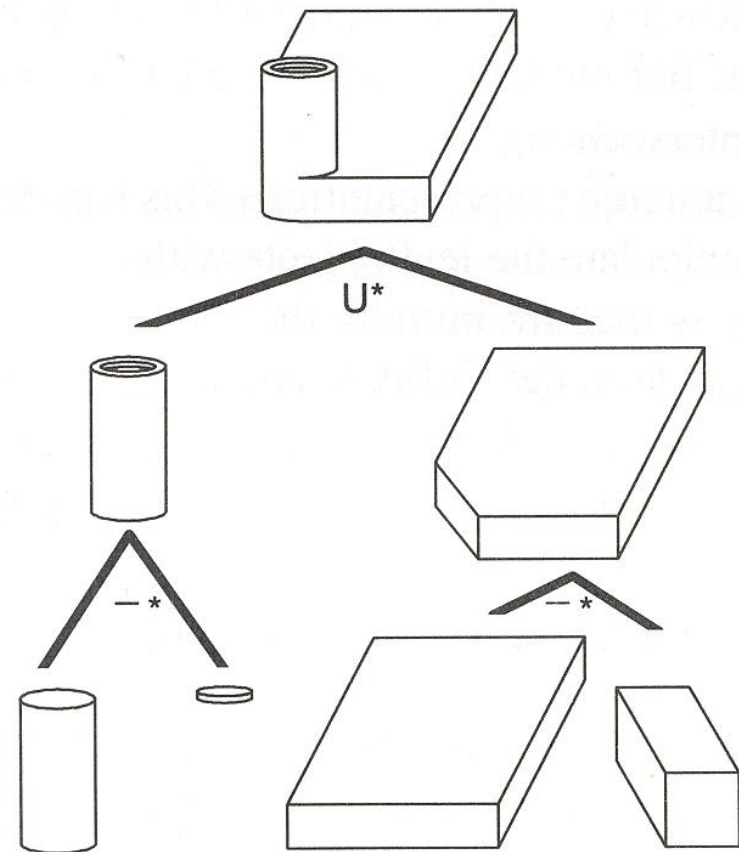

Polygonal Mesh Processing



Procedural generation

- Surface of revolution
- Sweep

Polygonal Mesh Processing



Procedural generation

- Surface of revolution
- Sweep

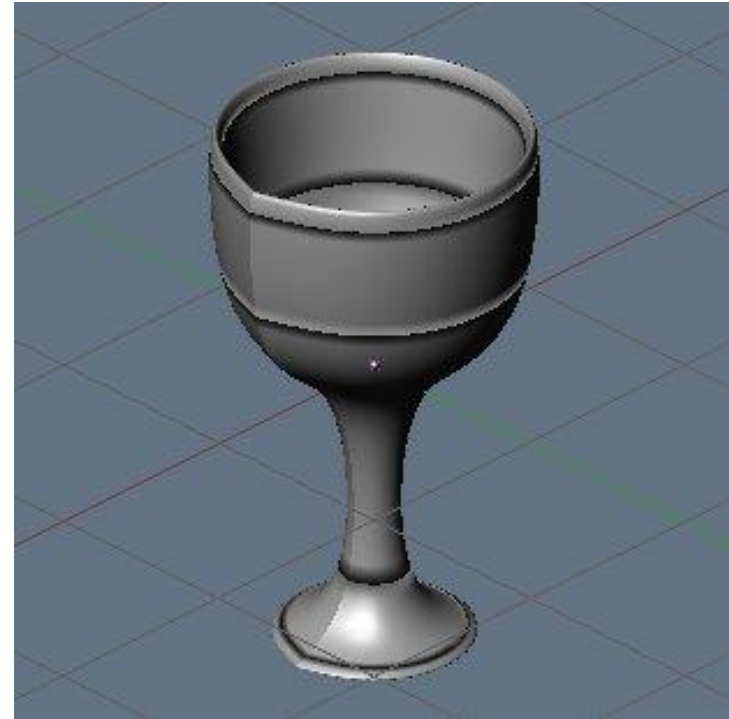
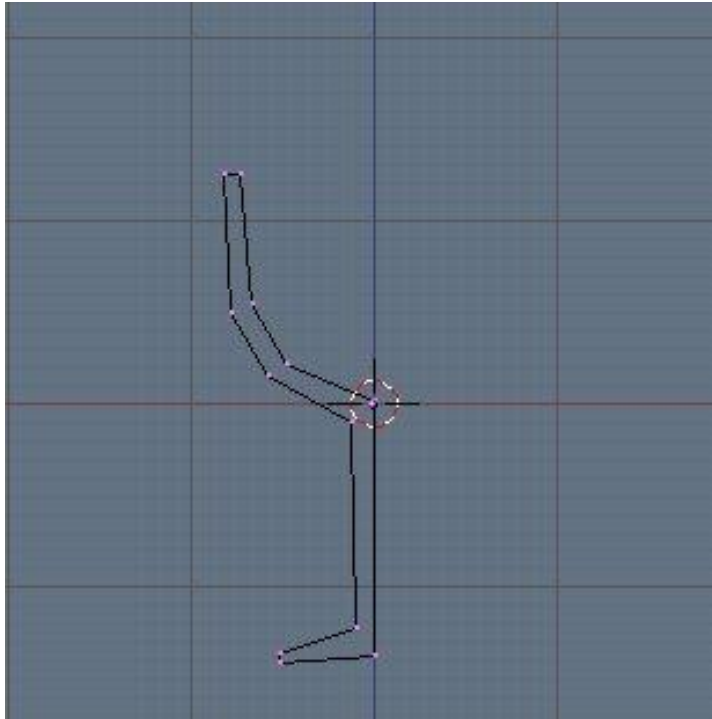

Polygonal Mesh Processing



Procedural generation

- Surface of revolution
- Sweep

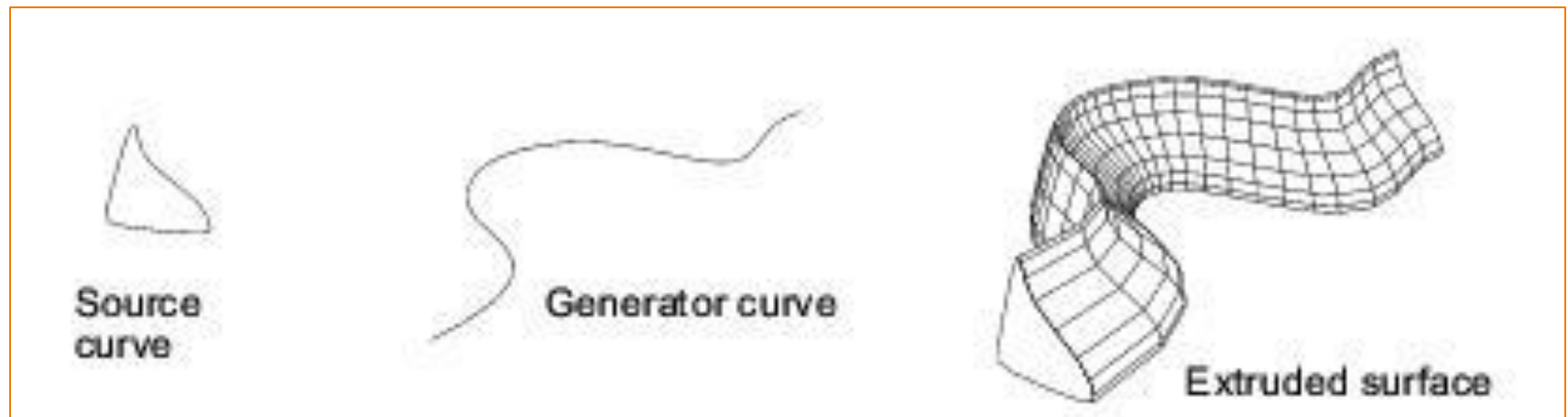
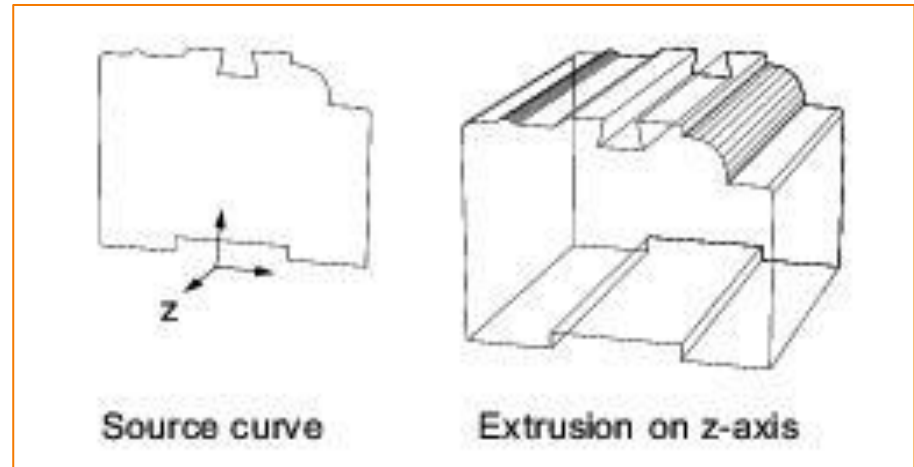

Polygonal Mesh Processing



Procedural generation

- Surface of revolution
- Sweep

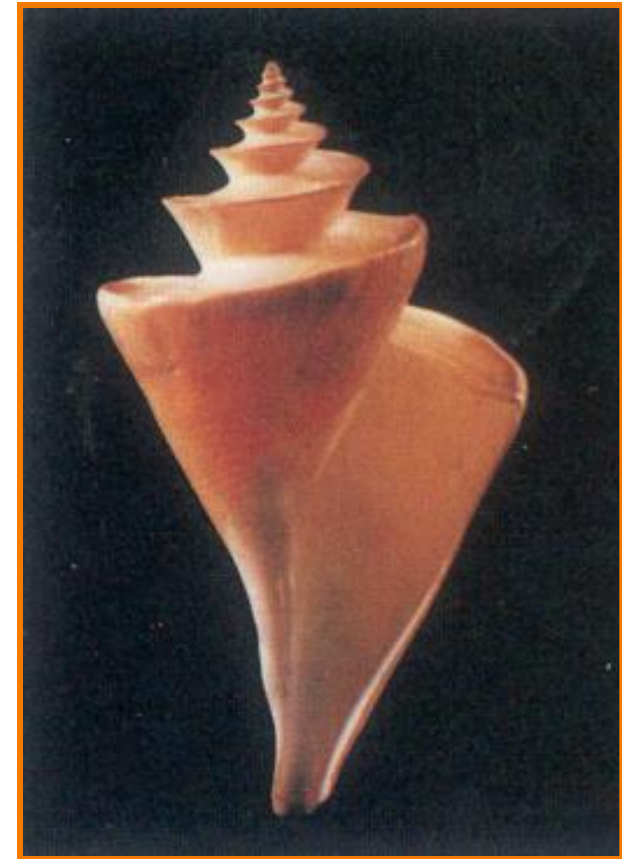
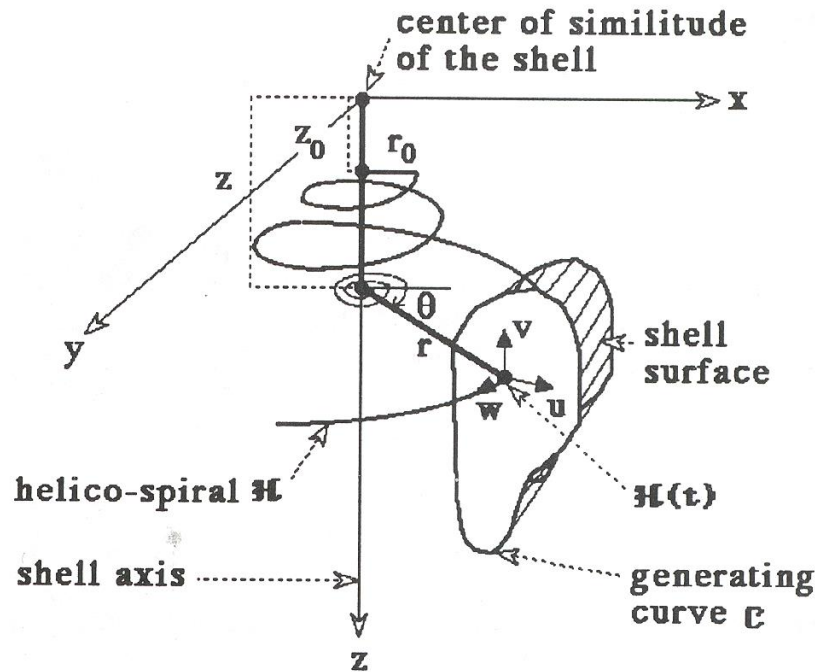

Polygonal Mesh Processing



Procedural generation

- Surface of revolution
- Sweep



Outline



Acquisition

Processing

Representation ←

Polygon Mesh Representation



Important properties of mesh representation?

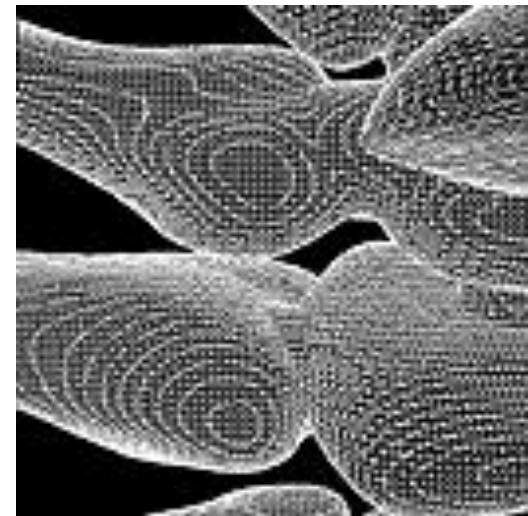
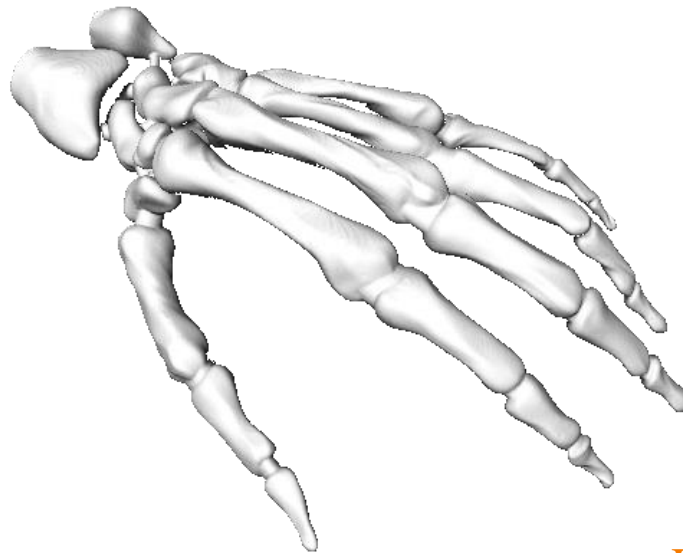

Large Geometric Model Repository
Georgia Tech

Polygon Mesh Representation



Important properties of mesh representation?

- Efficient traversal of topology
- Efficient use of memory
- Efficient updates

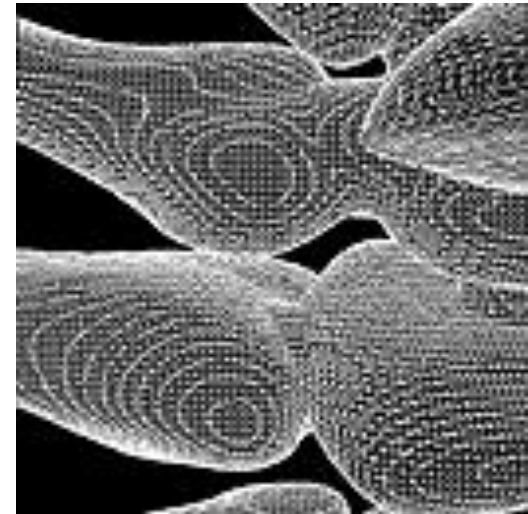
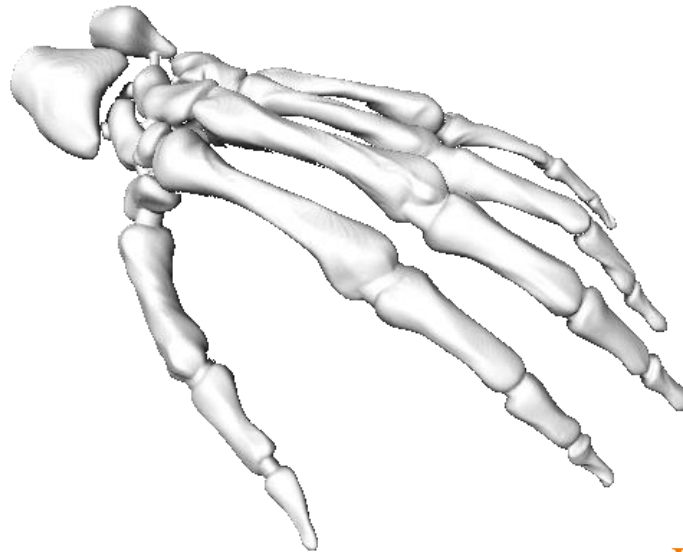

Large Geometric Model Repository
Georgia Tech

Polygon Mesh Representation



Possible data structures

- List of independent faces
- Vertex and face tables
- Adjacency lists
- Winged edge
- Half edge
- etc.

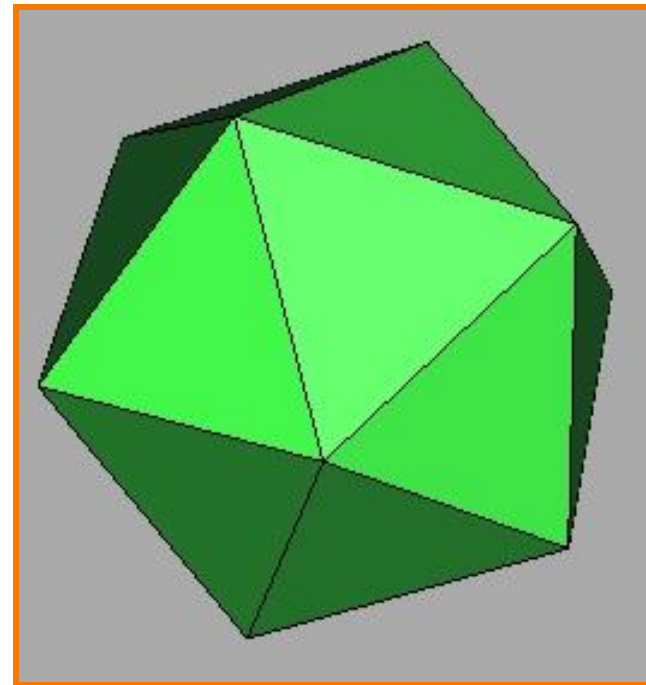

Independent Faces

Each face lists vertex coordinates

- Redundant vertices
- No adjacency information

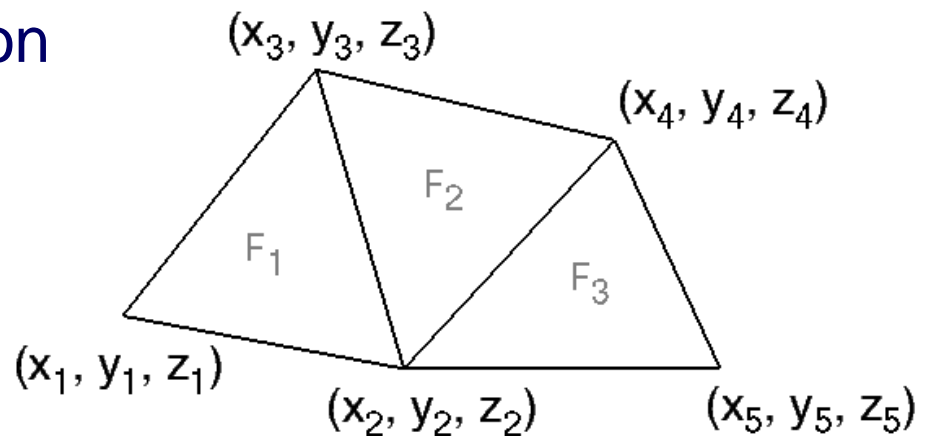
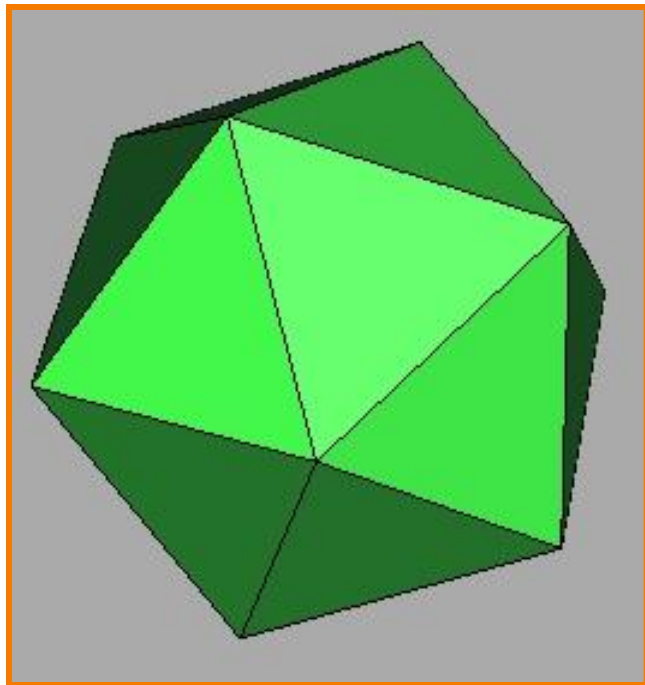

FACE TABLE

F_1	(x_1, y_1, z_1)	(x_2, y_2, z_2)	(x_3, y_3, z_3)
F_2	(x_2, y_2, z_2)	(x_4, y_4, z_4)	(x_3, y_3, z_3)
F_3	(x_2, y_2, z_2)	(x_5, y_5, z_5)	(x_4, y_4, z_4)

Vertex and Face Tables

Each face lists vertex references

- Shared vertices
- Still no adjacency information

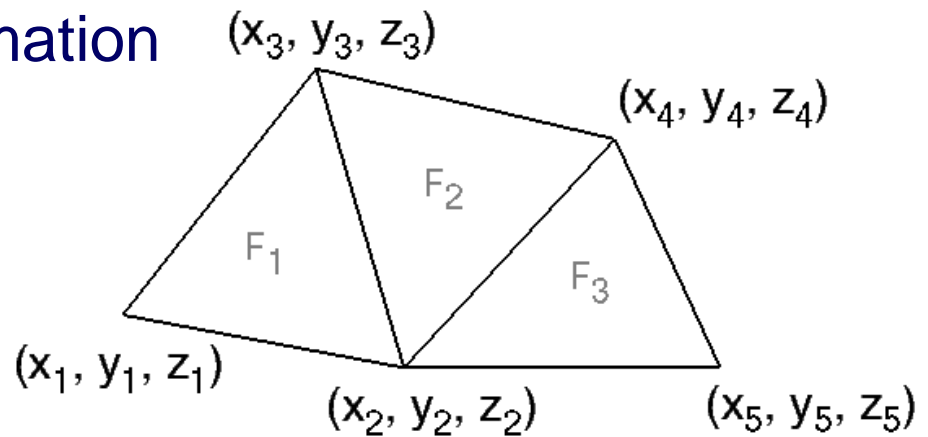
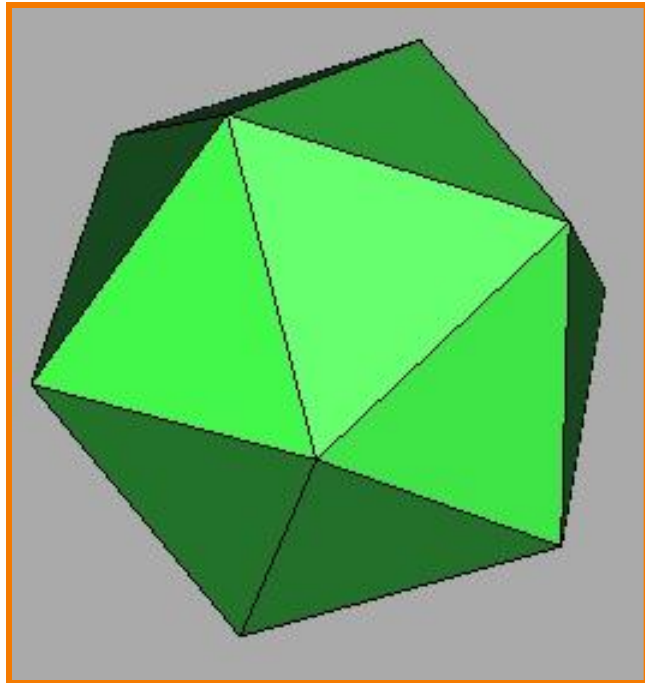

VERTEX TABLE			
V ₁	X ₁	Y ₁	Z ₁
V ₂	X ₂	Y ₂	Z ₂
V ₃	X ₃	Y ₃	Z ₃
V ₄	X ₄	Y ₄	Z ₄
V ₅	X ₅	Y ₅	Z ₅

FACE TABLE			
F ₁	V ₁	V ₂	V ₃
F ₂	V ₂	V ₄	V ₃
F ₃	V ₂	V ₅	V ₄

Adjacency Lists

Store all vertex, edge, and face adjacencies

- Efficient adjacency traversal
- Extra storage

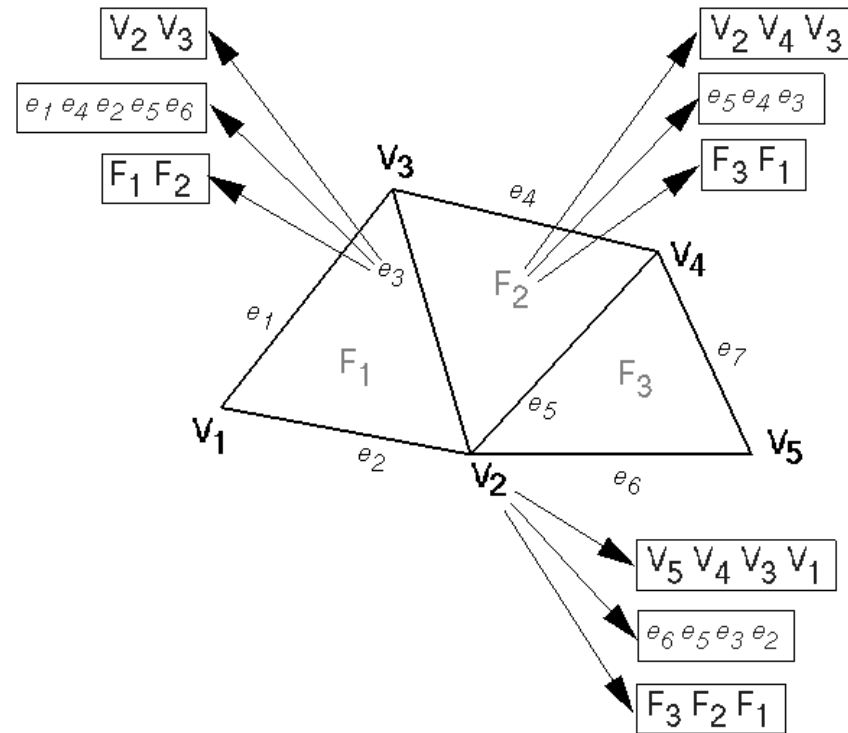
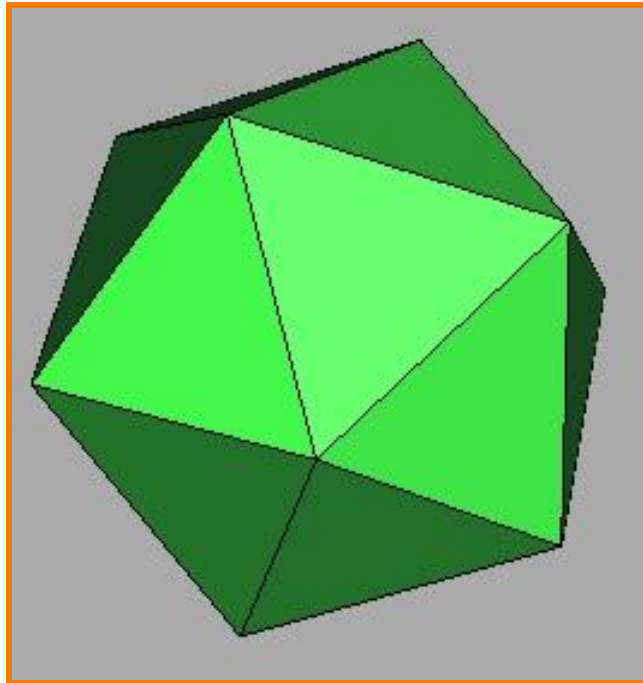

Partial Adjacency Lists

Can we store only some adjacency relationships and derive others?

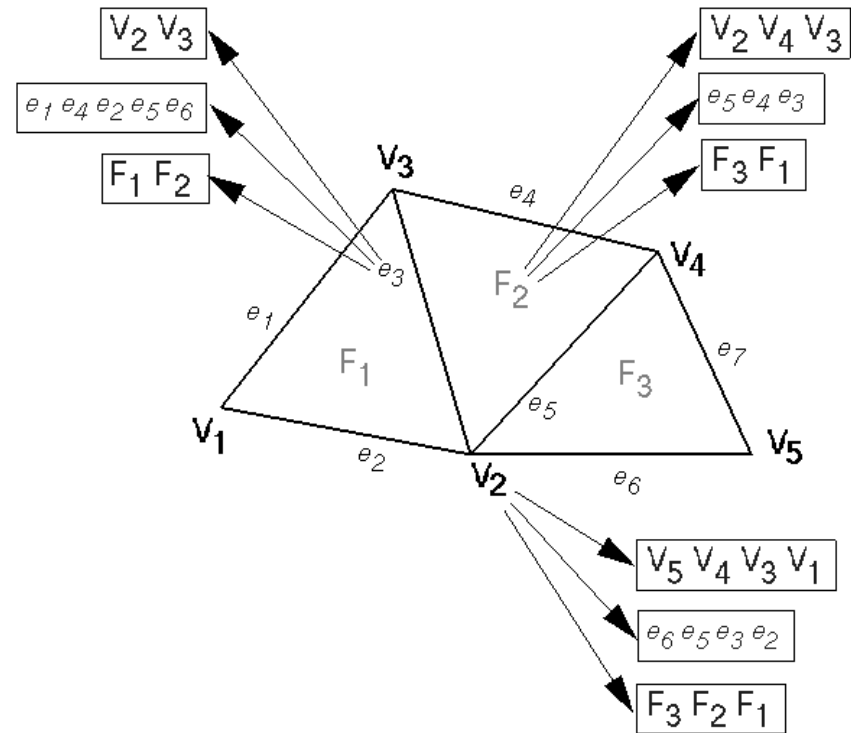
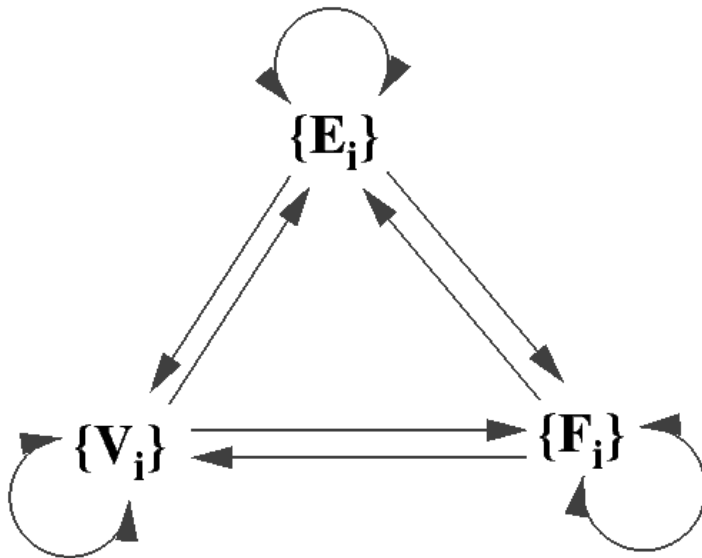

Winged Edge

Adjacency encoded in edges

- All adjacencies in $O(1)$ time
- Little extra storage (fixed records)
- Arbitrary polygons

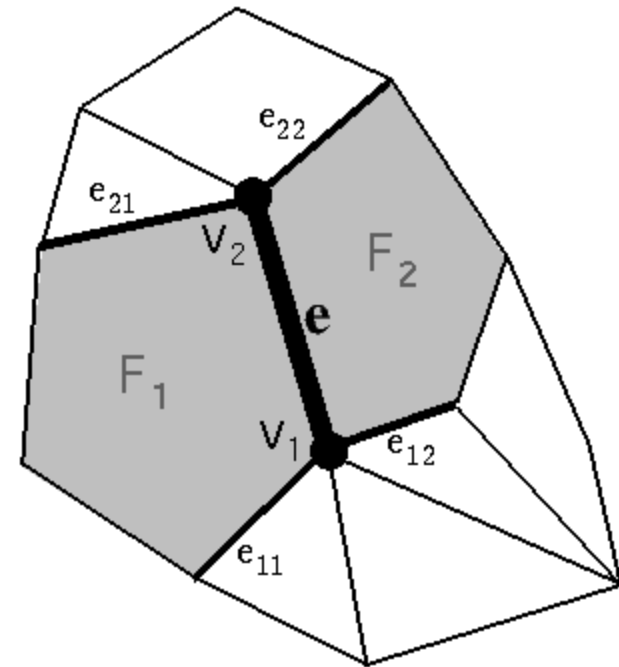
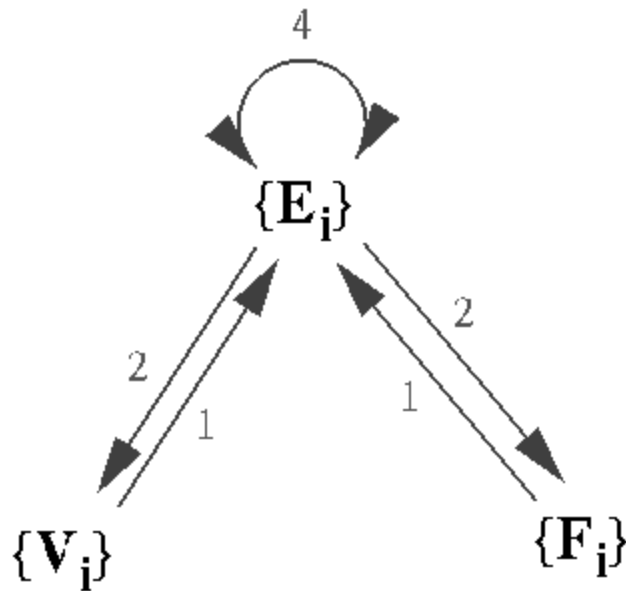



Winged Edge

Example:

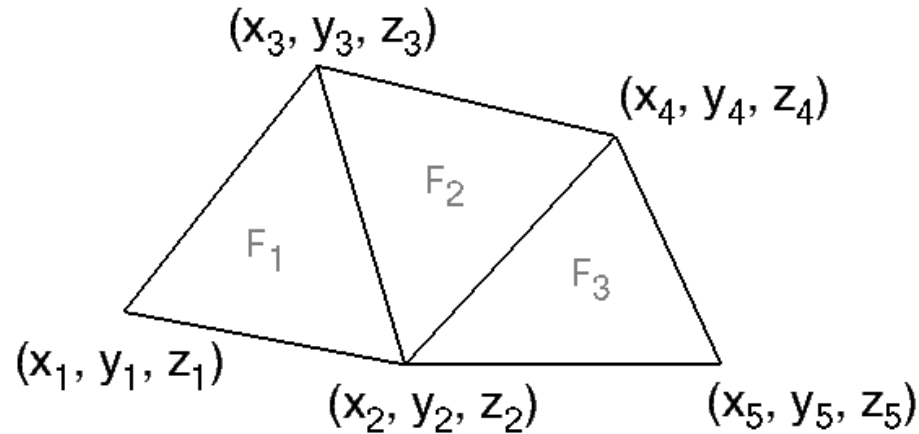

VERTEX TABLE				
V ₁	X ₁	Y ₁	Z ₁	e ₁
V ₂	X ₂	Y ₂	Z ₂	e ₆
V ₃	X ₃	Y ₃	Z ₃	e ₃
V ₄	X ₄	Y ₄	Z ₄	e ₅
V ₅	X ₅	Y ₅	Z ₅	e ₆

EDGE TABLE				11	12	21	22
e ₁	V ₁	V ₃	F ₁	e ₂	e ₂	e ₄	e ₃
e ₂	V ₁	V ₂	F ₁	e ₁	e ₁	e ₃	e ₆
e ₃	V ₂	V ₃	F ₁ F ₂	e ₂	e ₅	e ₁	e ₄
e ₄	V ₃	V ₄	F ₂	e ₁	e ₃	e ₇	e ₅
e ₅	V ₂	V ₄	F ₂ F ₃	e ₃	e ₆	e ₄	e ₇
e ₆	V ₂	V ₅	F ₃	e ₅	e ₂	e ₇	e ₇
e ₇	V ₄	V ₅	F ₃	e ₄	e ₅	e ₆	e ₆

FACE TABLE	
F ₁	e ₁
F ₂	e ₃
F ₃	e ₅

Half Edge

Adjacency encoded in edges

- All adjacencies in $O(1)$ time
- Little extra storage (fixed records)
- Arbitrary polygons

Similar to winged-edge,
except adjacency
encoded in half-edges

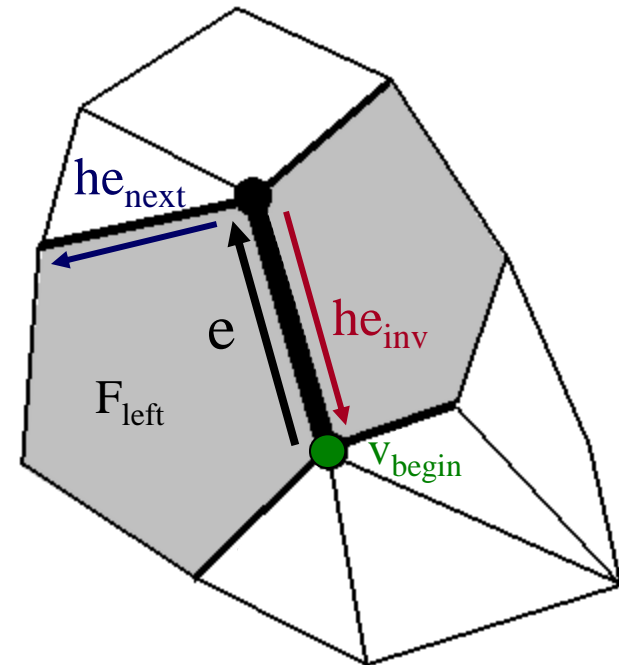

Summary



Polygonal meshes

- Most common surface representation
- Fast rendering

Processing operations

- Must consider irregular vertex sampling
- Must handle/avoid topological degeneracies

Representation

- Which adjacency relationships to store depend on which operations must be efficient

3D Polygonal Meshes



Properties

- ? Efficient display
- ? Easy acquisition
- ? Accurate
- ? Concise
- ? Intuitive editing
- ? Efficient editing
- ? Efficient intersections
- ? Guaranteed validity
- ? Guaranteed smoothness
- ? etc.

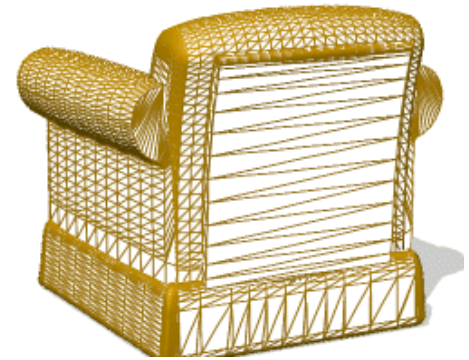
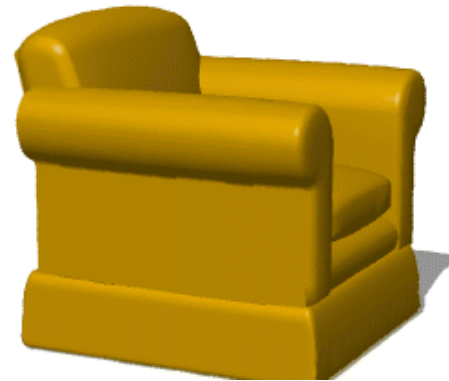

3D Polygonal Meshes



Properties

- ☺ Efficient display
- ☺ Easy acquisition
- ☹ Accurate
- ☹ Concise
- ☹ Intuitive editing
- ☹ Efficient editing
- ☹ Efficient intersections
- ☹ Guaranteed validity
- ☹ Guaranteed smoothness

