

The science that
drives modern
computers.

COS 116: 4/10/2006

Adam Finkelstein

Changing face of manufacturing

1936

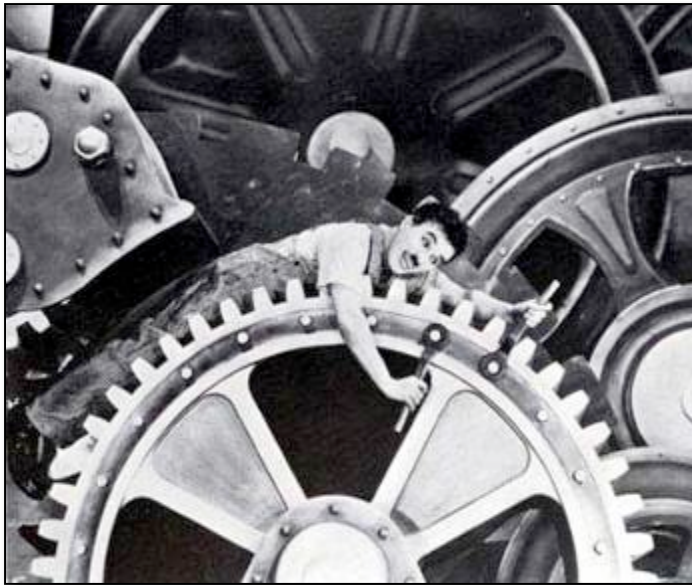

“Modern Times”

Late 20th century



Silicon wafer fabrication



20th century science and IT: a match made in heaven?

“These are the days of miracles and wonders.” – Paul Simon, Graceland

Main theme in this lecture:

Scientific Advances → Ability to control matter precisely
→ Amazing products/computers

Moore's Law

Technology advances so that number of gates per square inch doubles every 18 months.

[Gordon Moore 1965]

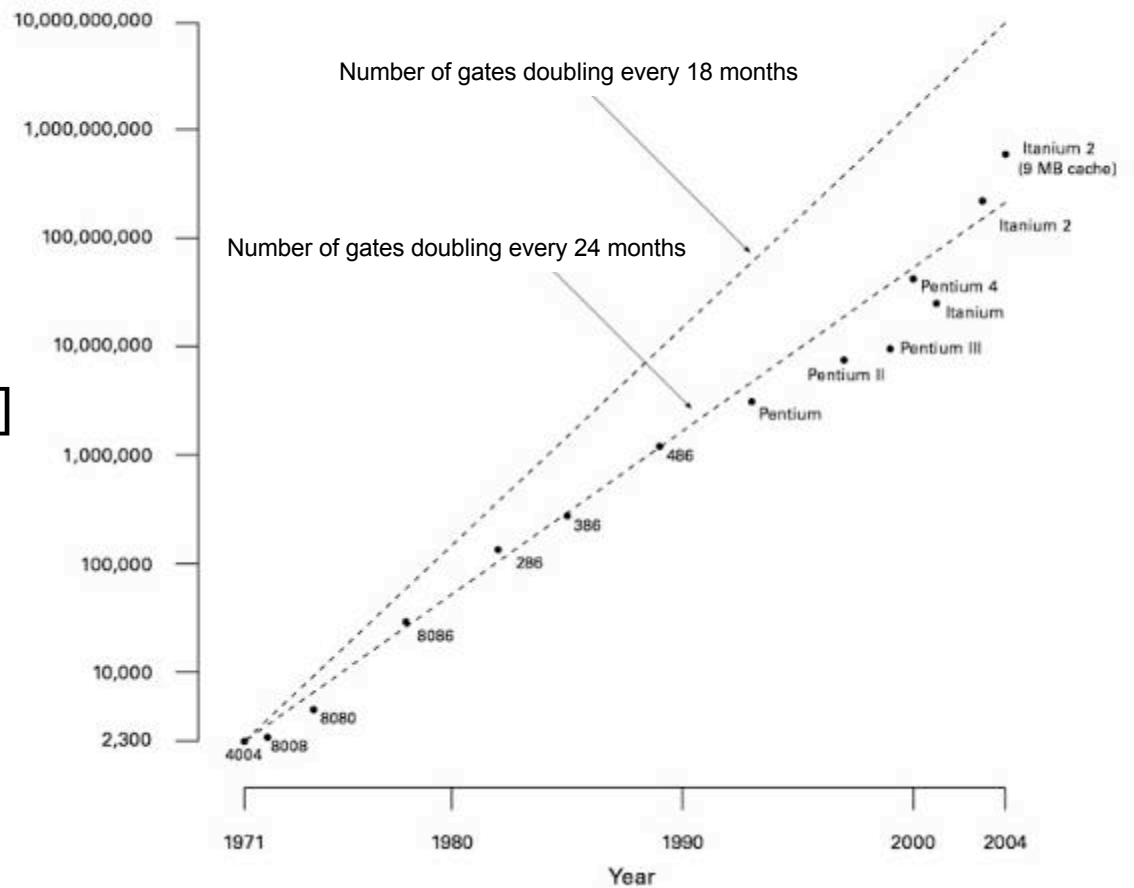

Example of precise control of matter: Lasers

- Quantum mechanics (wave-particle duality, quantization of energy, etc.)
- Ability to create light of a single frequency (“laser”)

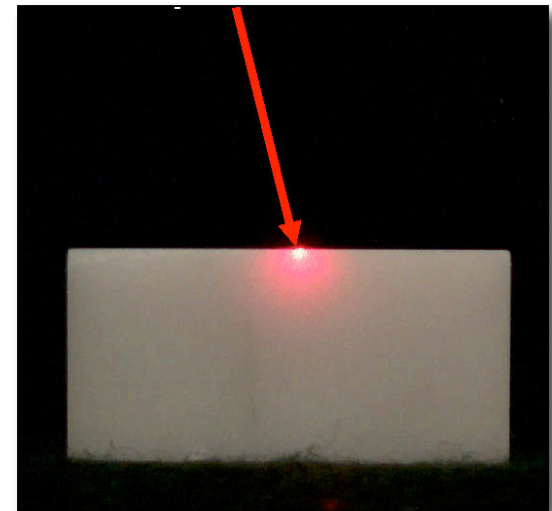
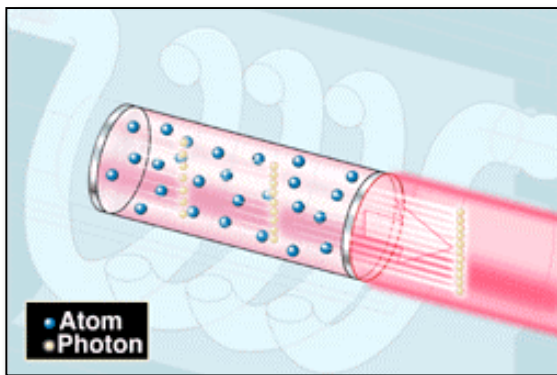

Why lasers are so useful: Accurate focusing



- White light

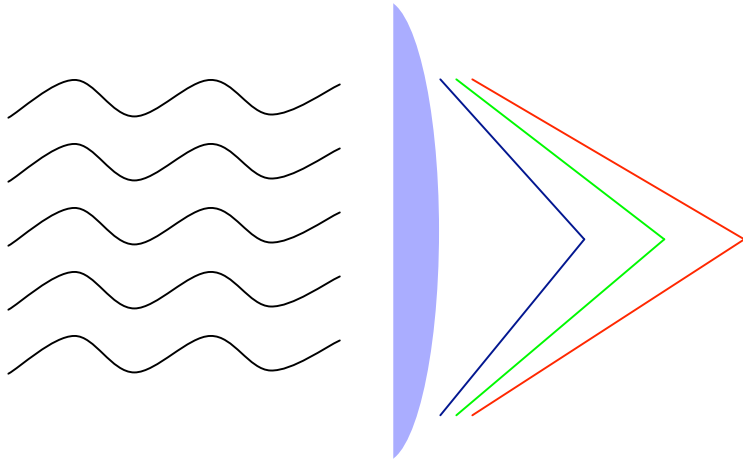

- Different colors focus at different points – “smudge”

- Laser

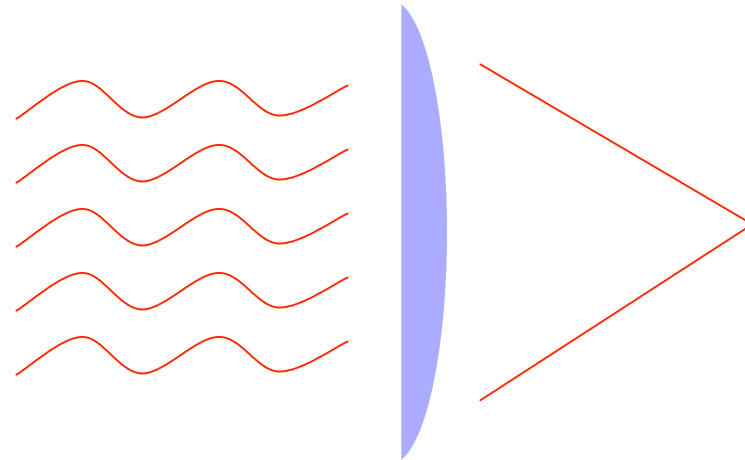

- Focus at single point

Silicon Chip manufacturing

“A picture is worth a billion gates.”



Fact: Modern chips are manufactured using a process similar to photography



Implementation of a gate in a modern chip

- **Semiconductor:**

not as good a conductor as metals,
not as bad as wood

- Example: silicon

- **Doped semiconductor:**

semiconductor with some (controlled) impurities:
p-type, n-type

- **Switch:** p-n junction

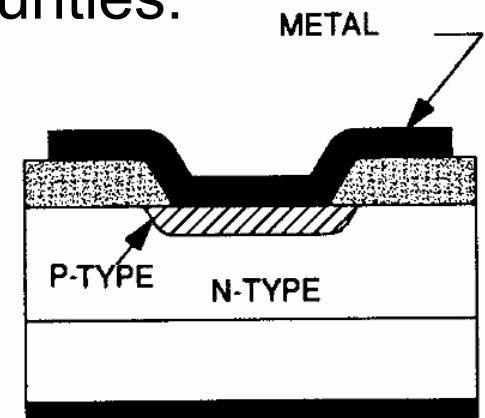
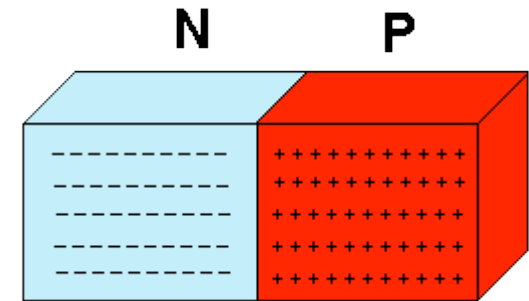

Example: an AND gate

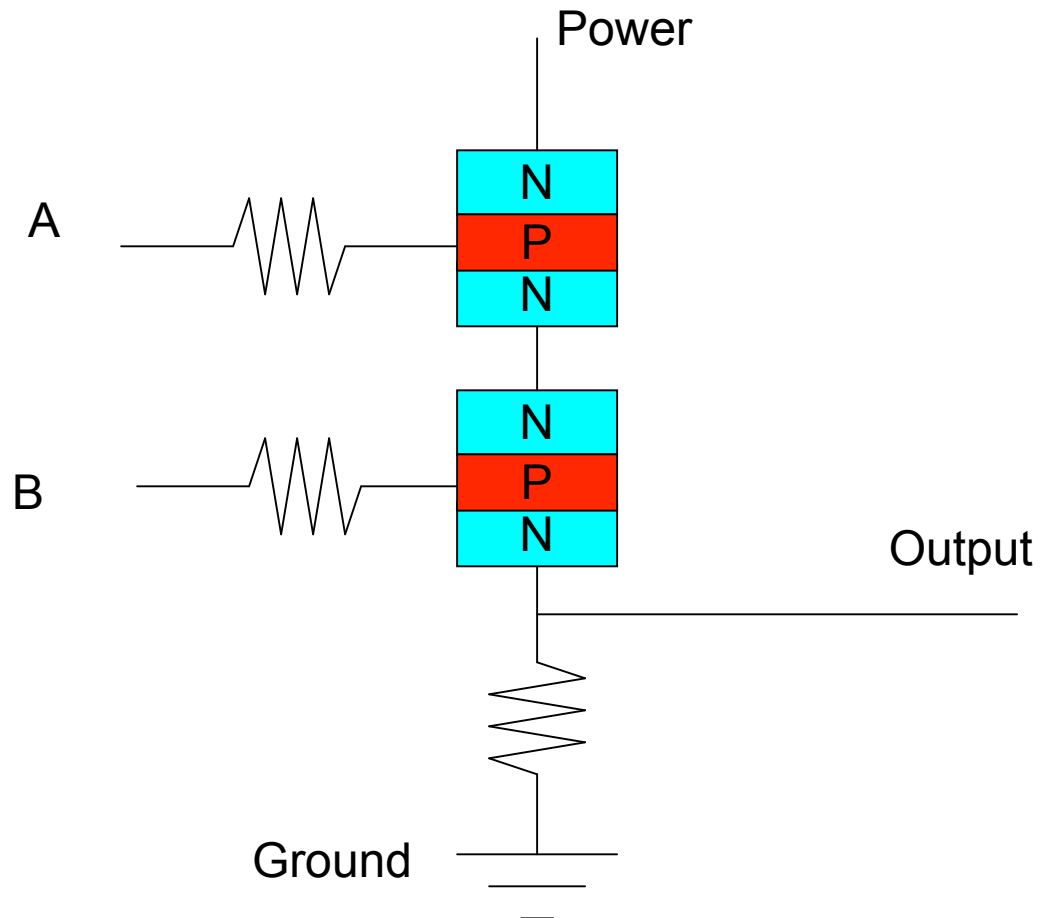

Chip Fabrication



Grow silicon ingots

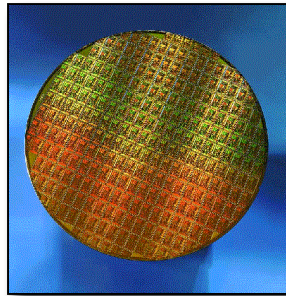

Cut wafers and polish

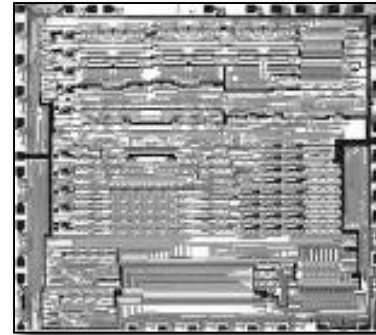

Create mask

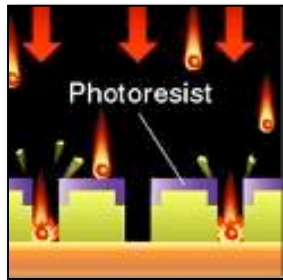

Coat wafer with light sensitive chemicals and project mask onto it

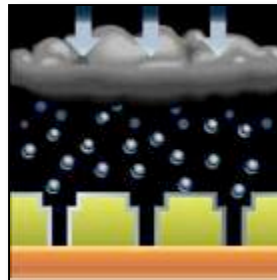

Coat with chemicals that remove parts unexposed to light



Repeat to add metal channels (wires) and insulation; many layers!

Aside: Lasik eye correction

Uses laser invented for chip fabrication



Chip Packaging

- Inside

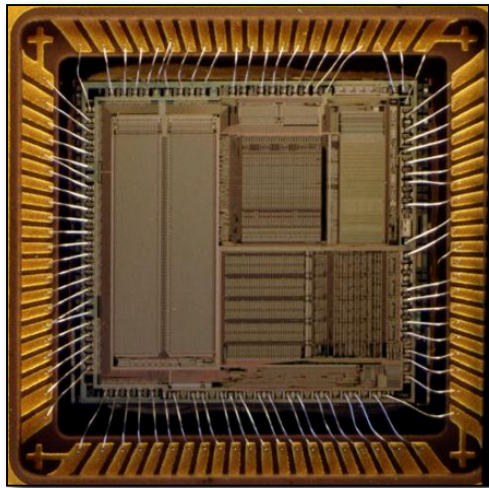

- Outside

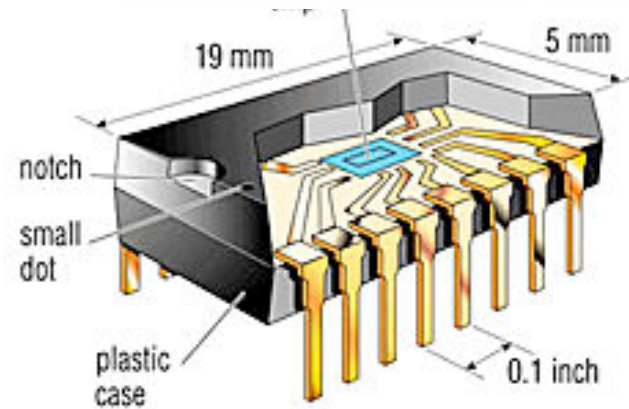
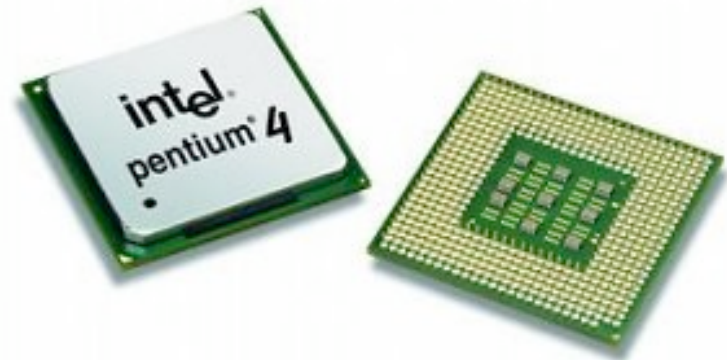

Life cycle of a microprocessor

Fact: Less than 1% of microprocessors sold are used in computers

Inside an iPod Remote

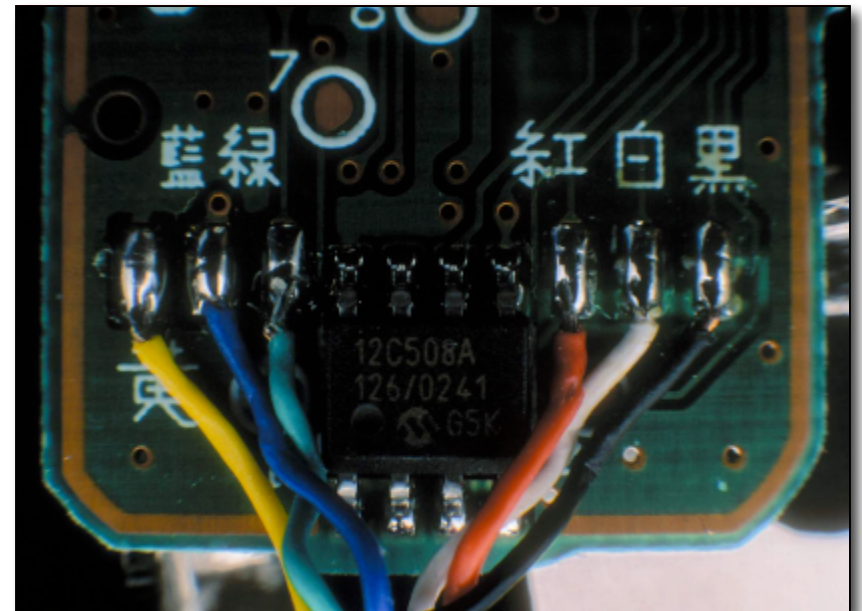

Why so few new CPU's?

Cost of new design: \$8 billion

- Profit: \$100 / chip
- Need to sell 80 million to break even

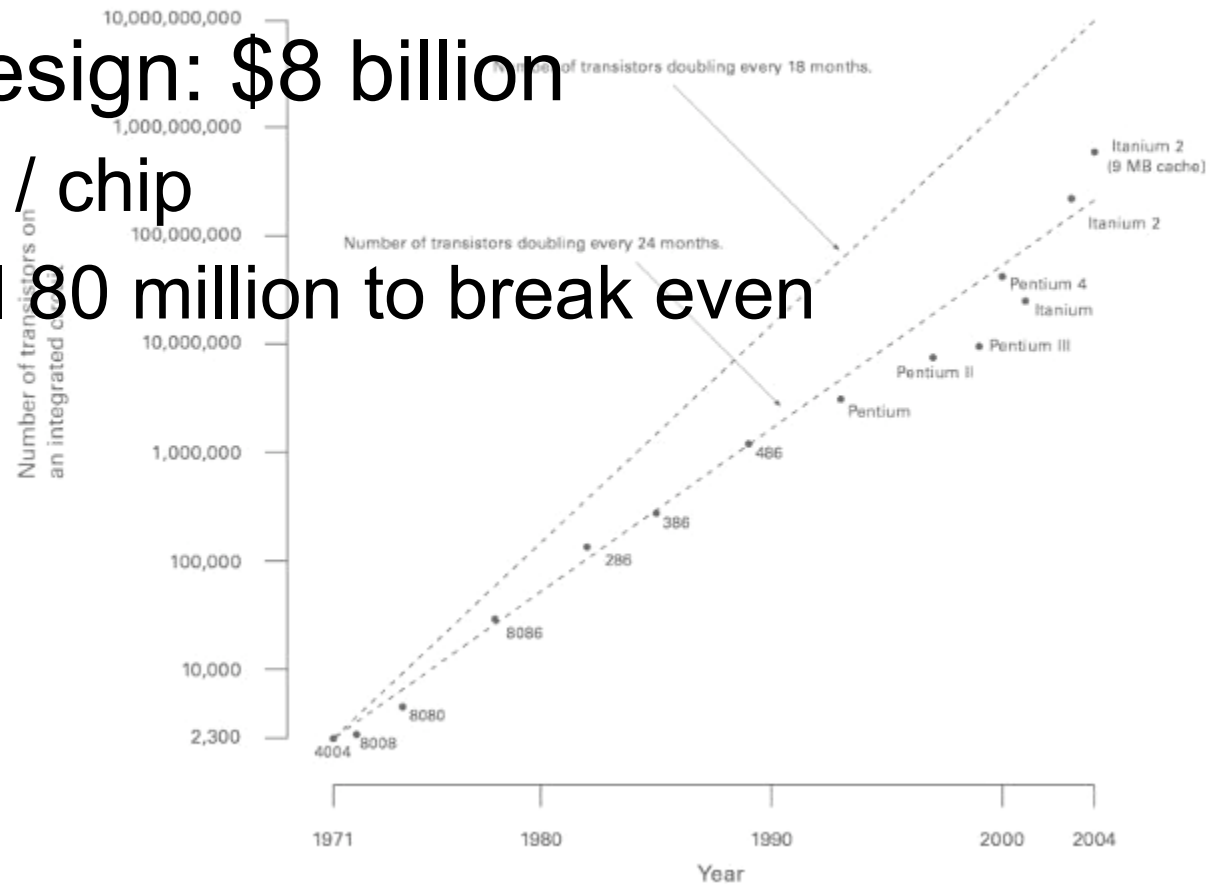

Engineering tradeoffs

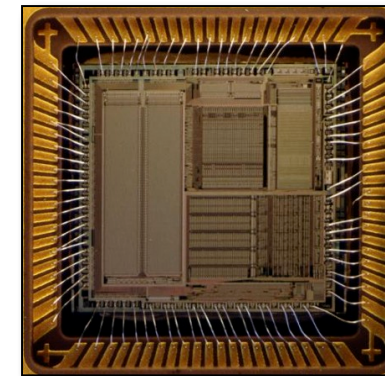
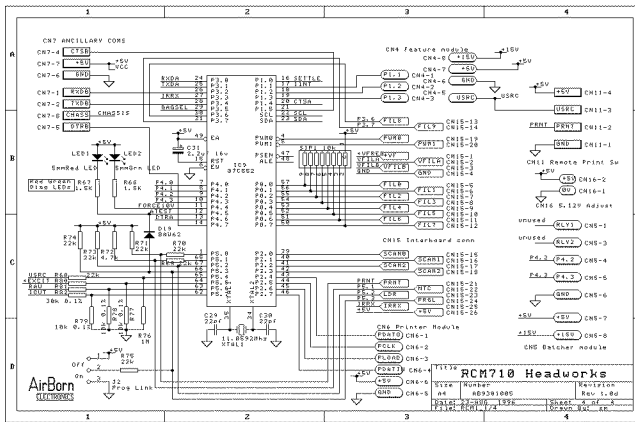

36 months later...

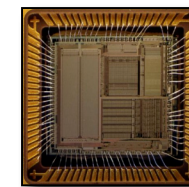

Half the size!

- Can run at twice the clock speed! (Why?)
- But: higher clock speeds → much more heat!



Even more precise control of matter: Nanotechnology

Technology to manufacture objects (machines, robots, etc.)
at the atomic or molecular level (1-100 nanometers)

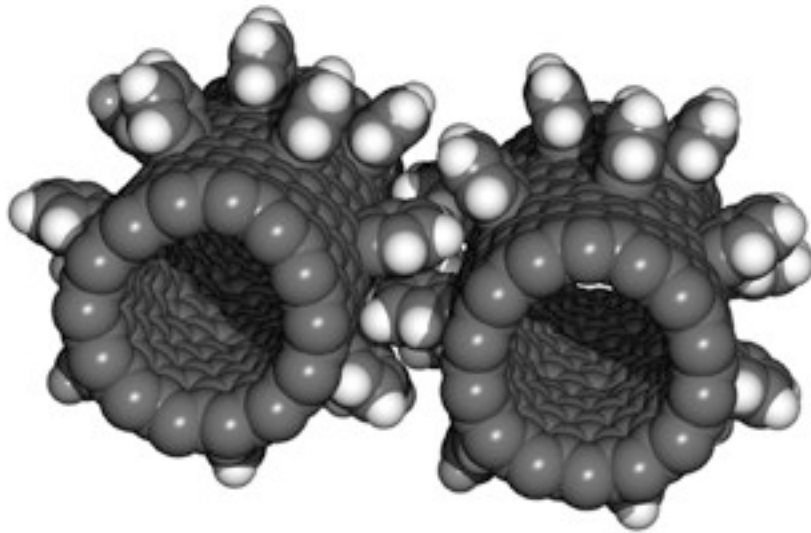

“nanogear”

Another example of control of matter: the changing data cable



- Serial cable: 115 kb/s



- USB cable: 480 Mb/s (USB 2.0)



- Fiber optic cable: 40 Gb/s

How optical fibers work



- Glass fiber: 10-40 billion bits/s

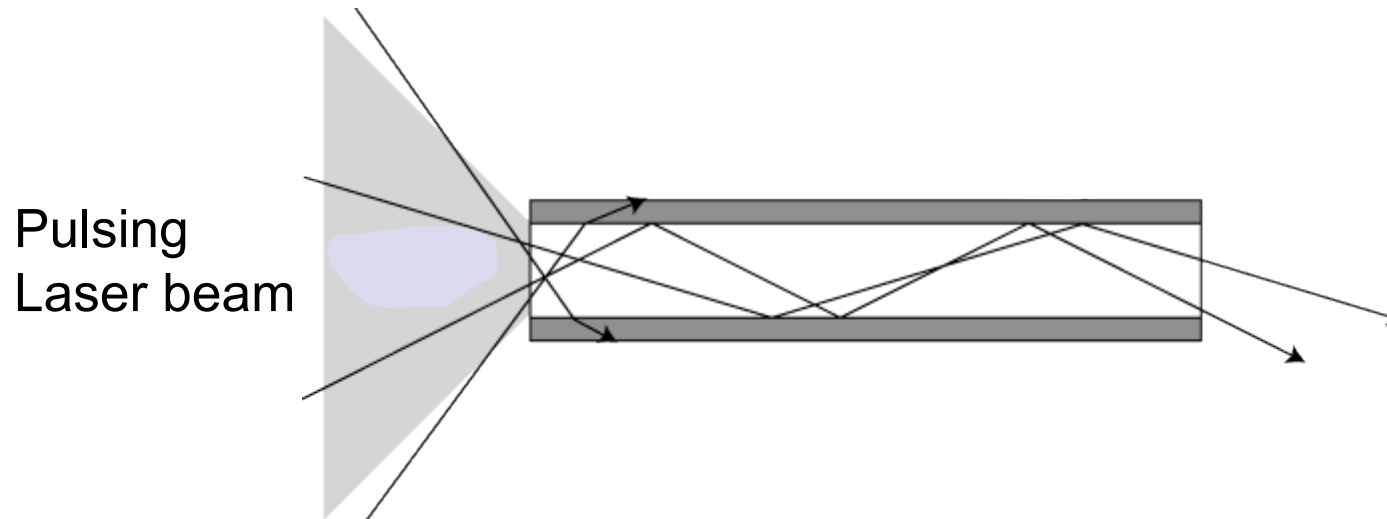

“Total internal reflection”

Wave Division Multiplexing (WDM)

Multiple (100 or so) data streams enter

Multiple data streams exit

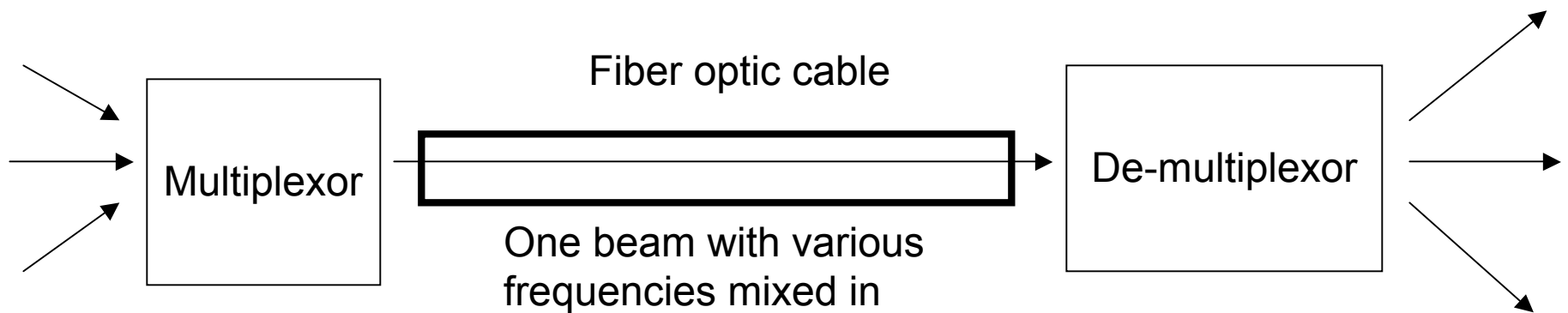

- Transmission rates of trillion (“Tera”) bits/s



Thoughts about the 20th century

- What factors (historical, political, social) gave rise to this knowledge explosion?
- Will it continue in the future?

*As we know,
There are known knowns.
There are things we know we know.
We also know
There are known unknowns.
That is to say
We know there are some things
We do not know.
But there are also unknown unknowns,
The ones we don't know
We don't know.*

— D. Rumsfeld, Feb. 12, 2002



Are faster chips the answer to
all problems in computing?

An Answer:

No! Halting problem is undecidable!



What about this decidable problem?

$$(A + B + C) \cdot (\bar{D} + F + G) \cdot (\bar{A} + G + K) \cdot (\bar{B} + P + Z) \cdot (C + \bar{U} + \bar{X})$$

- Does it have a satisfying assignment?
- What if instead we had 100 variables?
- 1000 variables?



Next lecture:

The computational cost of
automating serendipity

Discussion topic:

What is the difference between

- being creative and
- being able to appreciate creativity?