



Assembly Language: Function Calls

Goals of this Lecture



Help you learn:

- Function call problems
- x86-64 solutions
 - Pertinent instructions and conventions



Function Call Problems

(1) Calling and returning

- How does caller function **jump** to callee function?
- How does callee function **jump back** to the right place in caller function?

(2) Passing arguments

- How does caller function pass **arguments** to callee function?

(3) Storing local variables

- Where does callee function store its **local variables**?

(5) Returning a value

- How does callee function send **return value** back to caller function?
- How does caller function access the **return value**?

(6) Optimization

- How do caller and callee function minimize memory access?

Running Example



```
long absadd(long a, long b)
{
    long absA, absB, sum;
    absA = labs(a);
    absB = labs(b);
    sum = absA + absB;
    return sum;
}
```

Calls standard C `labs ()` function

- Returns absolute value of given `long`

Agenda



Calling and returning

Passing arguments

Storing local variables

Returning a value

Optimization

Problem 1: Calling and Returning



How does caller *jump* to callee?

- I.e., Jump to the address of the callee's first instruction

How does the callee *jump back* to the right place in caller?

- I.e., Jump to the instruction immediately following the most-recently-executed call instruction

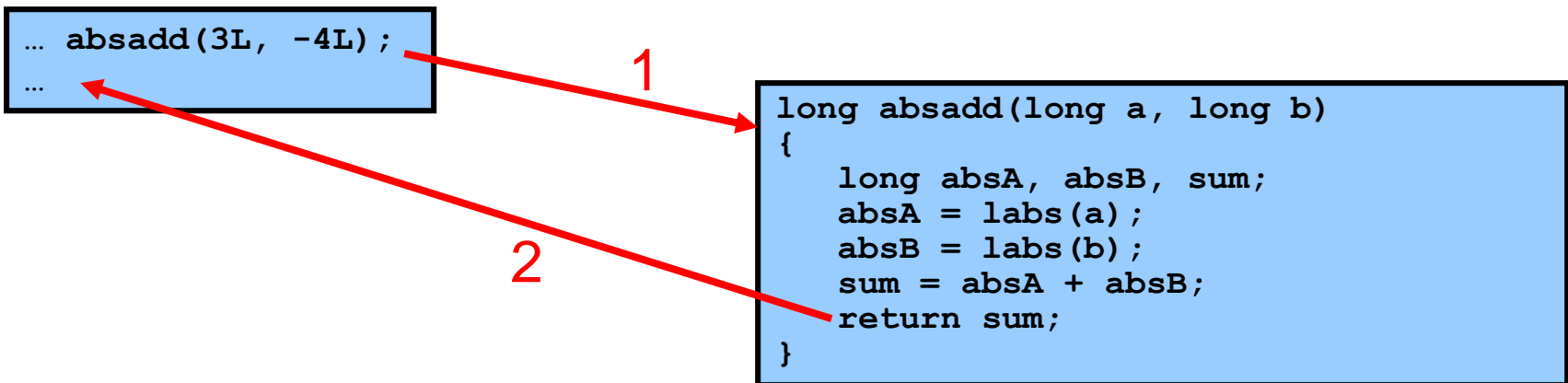

Attempted Solution: `jmp` Instruction



Attempted solution: caller and callee use `jmp` instruction

```
f:  
  
...  
  
    jmp g          # Call g  
fReturnPoint:  
  
...
```

```
g:  
  
...  
  
    jmp fReturnPoint # Return
```

Attempted Solution: `jmp` Instruction



Problem: callee may be called by multiple callers

```
f1:  
  
...  
  
    jmp g      # Call g  
f1ReturnPoint:  
  
...
```

```
g:  
  
...  
  
    jmp ???   # Return
```

```
f2:  
  
...  
  
    jmp g      # Call g  
f2ReturnPoint:  
  
...
```

Attempted Solution: Use Register



Attempted solution: Store return address in register

```
f1:
    movq $f1ReturnPoint, %rax
    jmp g      # Call g
f1ReturnPoint:
    ...
```

```
f2:
    movq $f2ReturnPoint, %rax
    jmp g      # Call g
f2ReturnPoint:
    ...
```

```
g:
    ...
    jmp *%rax # Return
```

Special form of
jmp instruction

Attempted Solution: Use Register



Problem: Cannot handle nested function calls

```
f:
    movq $fReturnPoint, %rax
    jmp g      # Call g
fReturnPoint:
    ...
```

```
g:
    movq $gReturnPoint, %rax
    jmp h      # Call h
gReturnPoint:
    ...
    jmp *%rax  # Return
```

Problem if `f ()` calls `g ()`,
and `g ()` calls `h ()`

Return address `g ()` -> `f ()`
is lost

```
h:
    ...
    jmp *%rax  # Return
```

x86-64 Solution: Use the Stack



Observations:

- May need to store many return addresses
 - The number of nested function calls is not known in advance
 - A return address must be saved for as long as the invocation of this function is live, and discarded thereafter
- Stored return addresses are destroyed in reverse order of creation
 - `f ()` calls `g ()` \Rightarrow return addr for `g` is stored
 - `g ()` calls `h ()` \Rightarrow return addr for `h` is stored
 - `h ()` returns to `g ()` \Rightarrow return addr for `h` is destroyed
 - `g ()` returns to `f ()` \Rightarrow return addr for `g` is destroyed
- LIFO data structure (stack) is appropriate

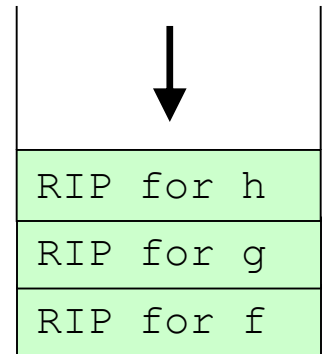

x86-64 solution:

- Use the `STACK` section of memory
- Via `call` and `ret` instructions

call and ret Instructions



ret instruction “knows” the return address

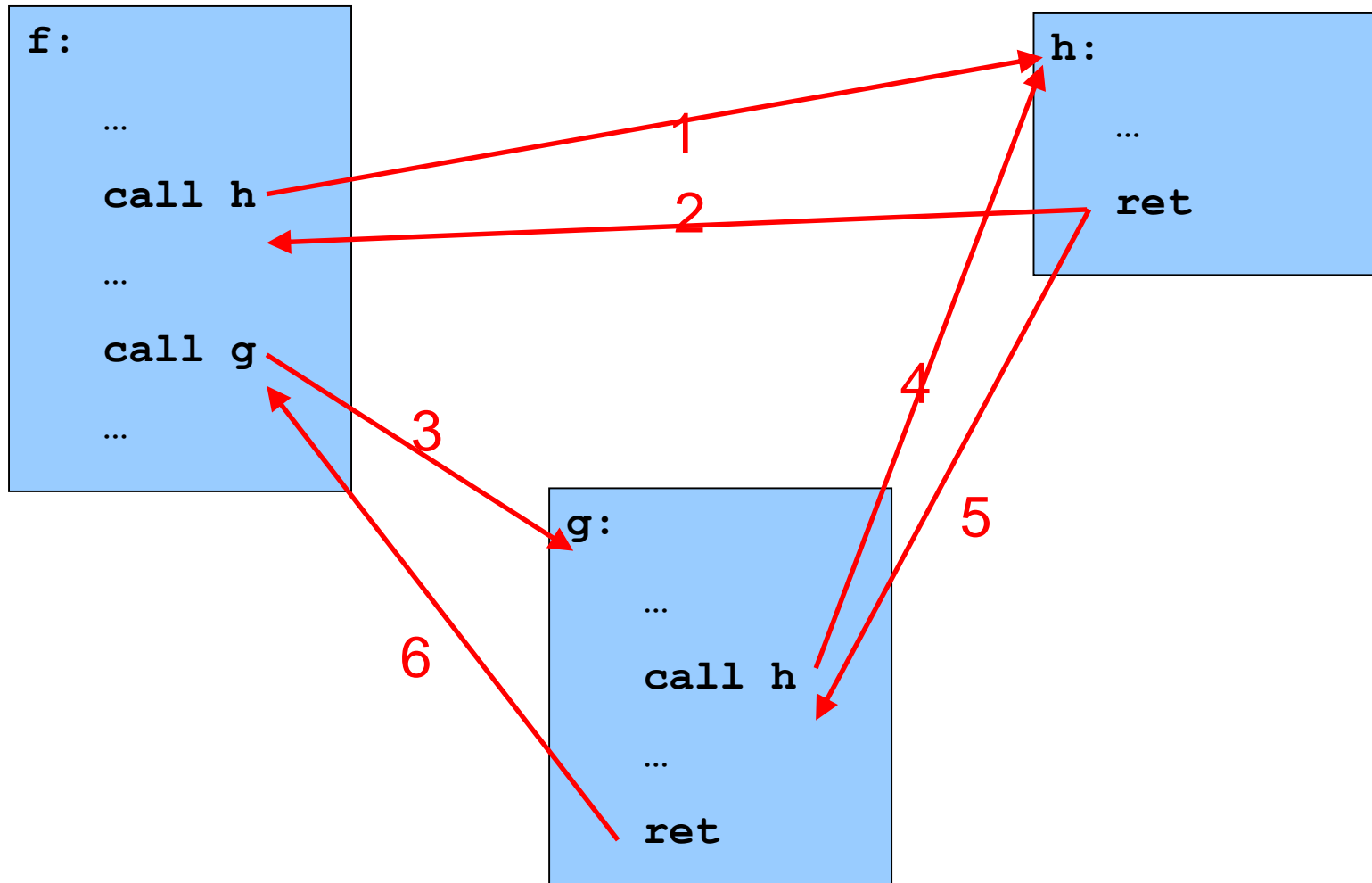



Implementation of call

RSP (stack pointer) register points to top of stack

Instruction	Equivalent to
<code>pushq src</code>	<code>subq \$8, %rsp</code> <code>movq src, (%rsp)</code>
<code>popq dest</code>	<code>movq (%rsp), dest</code> <code>addq \$8, %rsp</code>

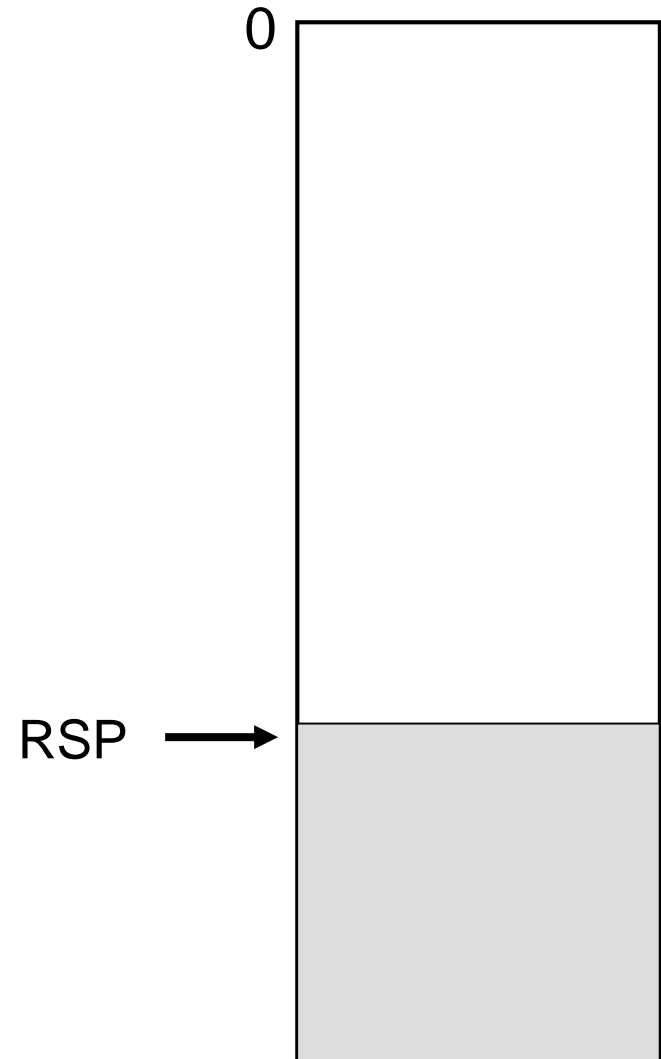



Implementation of call

RIP (instruction pointer) register points to next instruction to be executed

Instruction	Equivalent to
<code>pushq src</code>	<code>subq \$8, %rsp</code> <code>movq src, (%rsp)</code>
<code>popq dest</code>	<code>movq (%rsp), dest</code> <code>addq \$8, %rsp</code>
<code>call addr</code>	<code>pushq %rip</code> <code>jmp addr</code>

Note: Can't really access RIP directly, but this is implicitly what `call` is doing

RSP
before
call

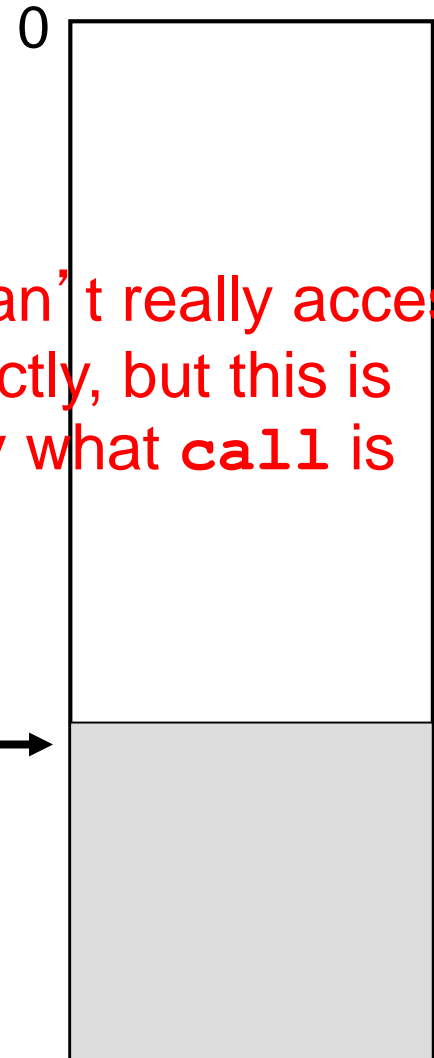

`call` instruction pushes return addr (old RIP) onto stack, then jumps

Implementation of call



Instruction	Effective Operations
<code>pushq src</code>	<code>subq \$8, %rsp</code> <code>movq src, (%rsp)</code>
<code>popq dest</code>	<code>movq (%rsp), dest</code> <code>addq \$8, %esp</code>
<code>call addr</code>	<code>pushq %rip</code> <code>jmp addr</code>

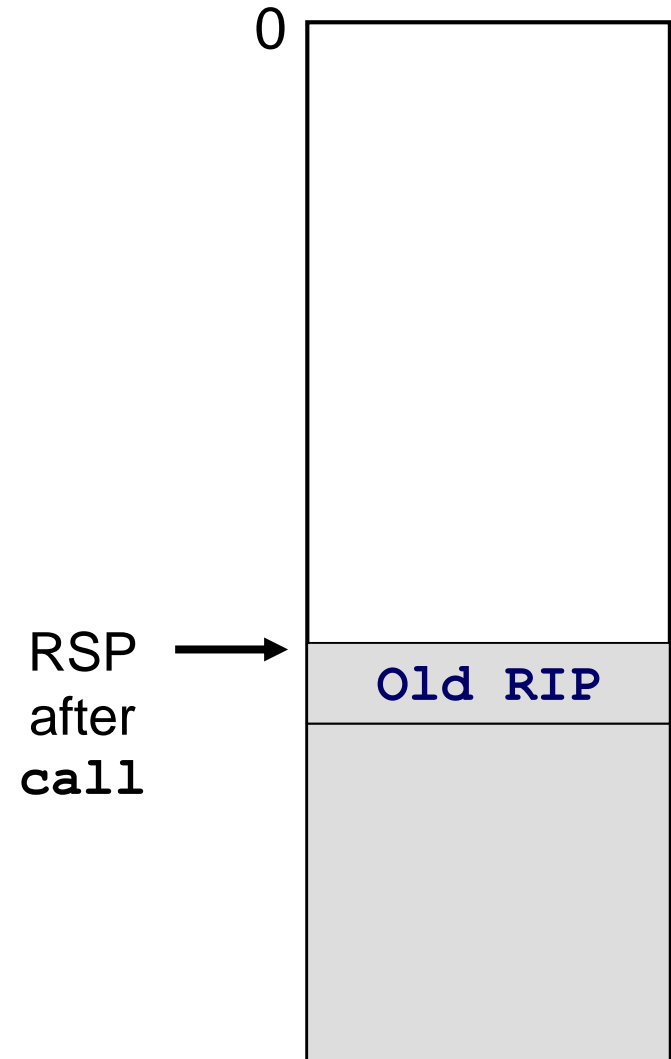



Implementation of `ret`

Instruction	Effective Operations
<code>pushq src</code>	<code>subq \$8, %rsp</code> <code>movq src, (%rsp)</code>
<code>popq dest</code>	<code>movq (%rsp), dest</code> <code>addq \$8, %rsp</code>
<code>call addr</code>	<code>pushq %rip</code> <code>jmp addr</code>
<code>ret</code>	<code>popq %rip</code>

Note: can't really access RIP directly, but this is implicitly what `ret` is doing

RSP before
`ret`

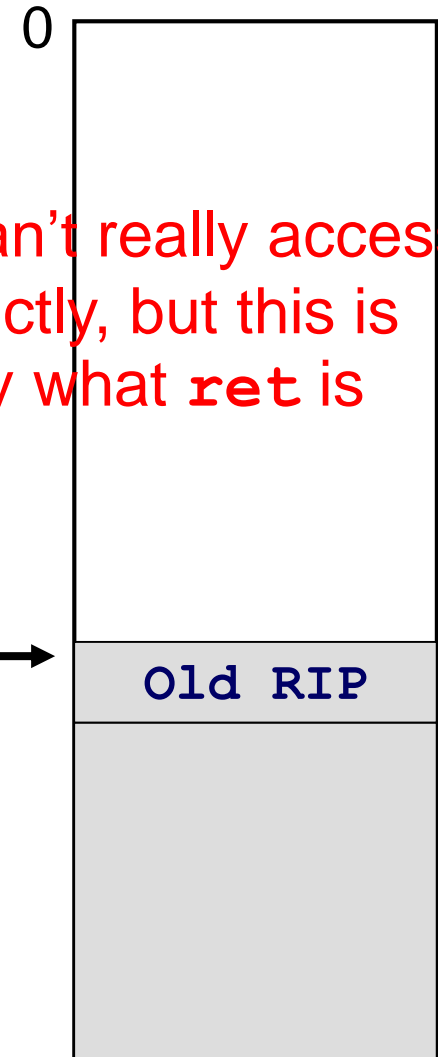

`ret` instruction pops stack, thus placing return addr (old RIP) into RIP

Implementation of `ret`



Instruction	Effective Operations
<code>pushq src</code>	<code>subq \$8, %rsp</code> <code>movq src, (%rsp)</code>
<code>popq dest</code>	<code>movq (%rsp), dest</code> <code>addq \$8, %rsp</code>
<code>call addr</code>	<code>pushq %rip</code> <code>jmp addr</code>
<code>ret</code>	<code>popq %rip</code>

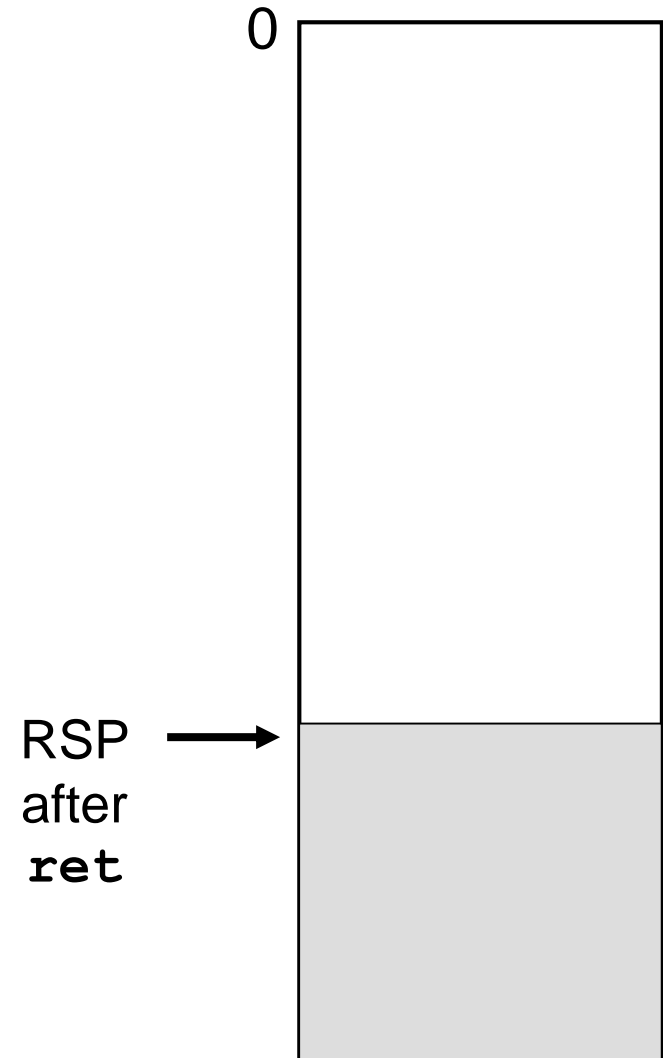

Running Example



```
# long absadd(long a, long b)
absadd:
    # long absA, absB, sum
    ...
    # absA = labs(a)
    ...
    call labs
    ...
    # absB = labs(b)
    ...
    call labs
    ...
    # sum = absA + absB
    ...
    # return sum
    ...
    ret
```

Agenda



Calling and returning

Passing arguments

Storing local variables

Returning a value

Optimization



Problem 2: Passing Arguments

Problem:

- How does caller pass *arguments* to callee?
- How does callee accept *parameters* from caller?

```
long absadd(long a, long b)
{
    long absA, absB, sum;
    absA = labs(a);
    absB = labs(b);
    sum = absA + absB;
    return sum;
}
```

X86-64 Solution 1: Use the Stack



Observations (déjà vu):

- May need to store many arg sets
 - The number of arg sets is not known in advance
 - Arg set must be saved for as long as the invocation of this function is live, and discarded thereafter
- Stored arg sets are destroyed in reverse order of creation
- LIFO data structure (stack) is appropriate

x86-64 Solution: Use the Stack



x86-64 solution:

- Pass first 6 (integer or address) arguments in registers
 - RDI, RSI, RDX, RCX, R8, R9
- More than 6 arguments \Rightarrow
 - Pass arguments 7, 8, ... on the stack
 - (Beyond scope of COS 217)
- Arguments are structures \Rightarrow
 - Pass arguments on the stack
 - (Beyond scope of COS 217)

Callee function then saves arguments to stack

- Or maybe not!
 - See “optimization” later this lecture
- Callee accesses arguments as positive offsets vs. RSP



Running Example

```
# long absadd(long a, long b)
absadd:
    pushq %rdi # Push a
    pushq %rsi # Push b

    # long absA, absB, sum
    ...
    # absA = labs(a)
    movq 8(%rsp), %rdi
    call labs
    ...
    # absB = labs(b)
    movq 0(%rsp), %rdi
    call labs
    ...
    # sum = absA + absB
    ...
    # return sum
    ...
    addq $16, %rsp
    ret
```

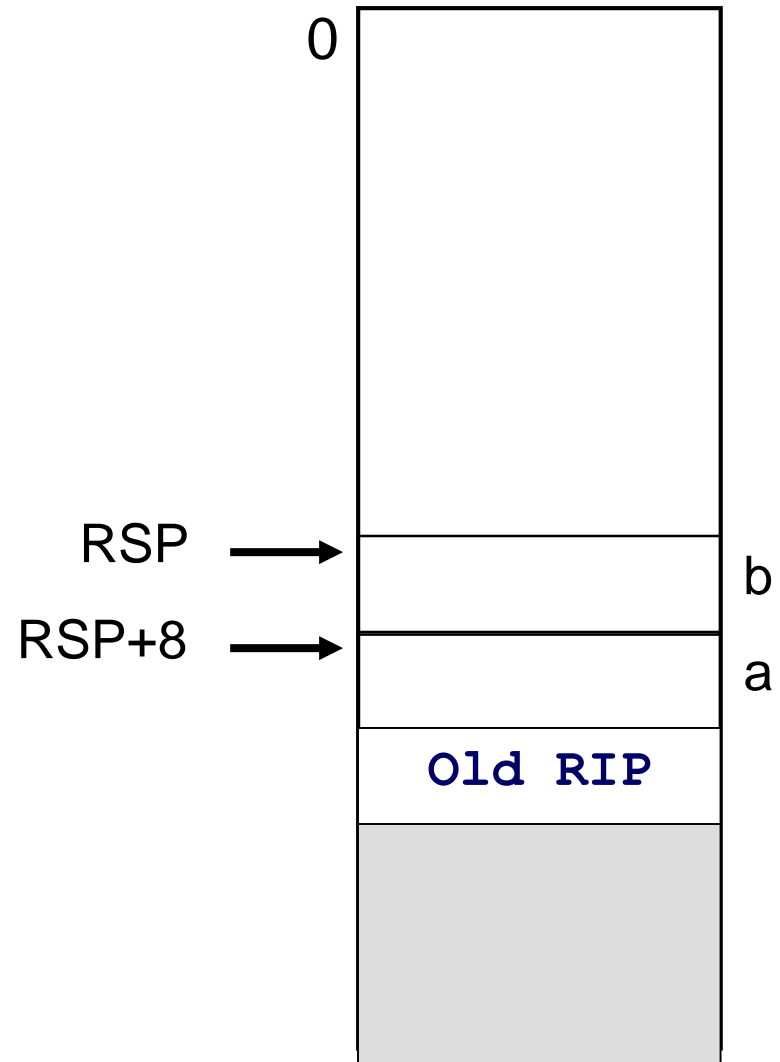

Agenda



Calling and returning

Passing arguments

Storing local variables

Returning a value

Optimization

Problem 3: Storing Local Variables



Where does callee function store its *local variables*?

```
long absadd(long a, long b)
{
    long absA, absB, sum;
    absA = labs(a);
    absB = labs(b);
    sum = absA + absB;
    return sum;
}
```

x86-64 Solution: Use the Stack



Observations (déjà vu again!):

- May need to store many local var sets
 - The number of local var sets is not known in advance
 - Local var set must be saved for as long as the invocation of this function is live, and discarded thereafter
- Stored local var sets are destroyed in reverse order of creation
- LIFO data structure (stack) is appropriate

x86-64 solution:

- Use the STACK section of memory
- Or maybe not!
 - See later this lecture



Running Example

```
# long absadd(long a, long b)
absadd:
    pushq %rdi # Push a
    pushq %rsi # Push b

    # long absA, absB, sum
    subq $24, %rsp

    # absA = labs(a)
    movq 32(%rsp), %rdi
    call labs
    ...
    # absB = labs(b)
    movq 24(%rsp), %rdi
    call labs
    ...
    # sum = absA + absB
    movq 16(%rsp), %rax
    addq 8(%rsp), %rax
    movq %rax, 0(%rsp)
    ...
    # return sum
    ...
    addq $40, %rsp
    ret
```

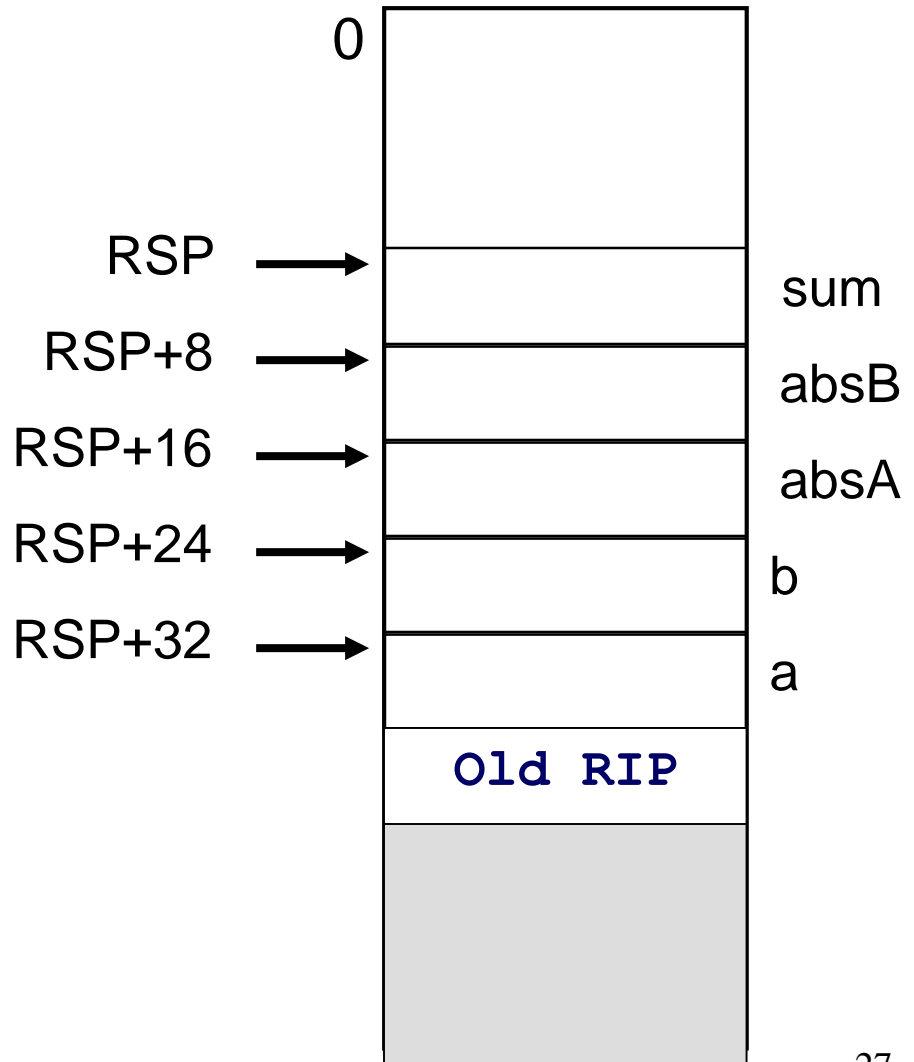



Agenda

Calling and returning

Passing arguments

Storing local variables

Returning a value

Optimization



Problem 4: Return Values

Problem:

- How does callee function send return value back to caller function?
- How does caller function access return value?

```
long absadd(long a, long b)
{
    long absA, absB, sum;
    absA = labs(a);
    absB = labs(b);
    sum = absA + absB;
    return sum;
}
```



x86-64 Solution: Use RAX

In principle

- Store return value in stack frame of caller

Or, for efficiency

- Known small size \Rightarrow store return value in register
- Other \Rightarrow store return value in stack

x86-64 convention

- Integer or address:
 - Store return value in RAX
- Floating-point number:
 - Store return value in floating-point register
 - (Beyond scope of COS 217)
- Structure:
 - Store return value on stack
 - (Beyond scope of COS 217)



Running Example

```
# long absadd(long a, long b)
absadd:
    pushq %rdi # Push a
    pushq %rsi # Push b

    # long absA, absB, sum
    subq $24, %rsp

    # absA = labs(a)
    movq 32(%rsp), %rdi
    call labs
    movq %rax, 16(%rsp)

    # absB = labs(b)
    movq 24(%rsp), %rdi
    call labs
    movq %rax, 8(%rsp)

    # sum = absA + absB
    movq 16(%rsp), %rax
    addq 8(%rsp), %rax
    movq %rax, 0(%rsp)

    # return sum
    movq 0(%rsp), %rax
    addq $40, %rsp
    ret
```

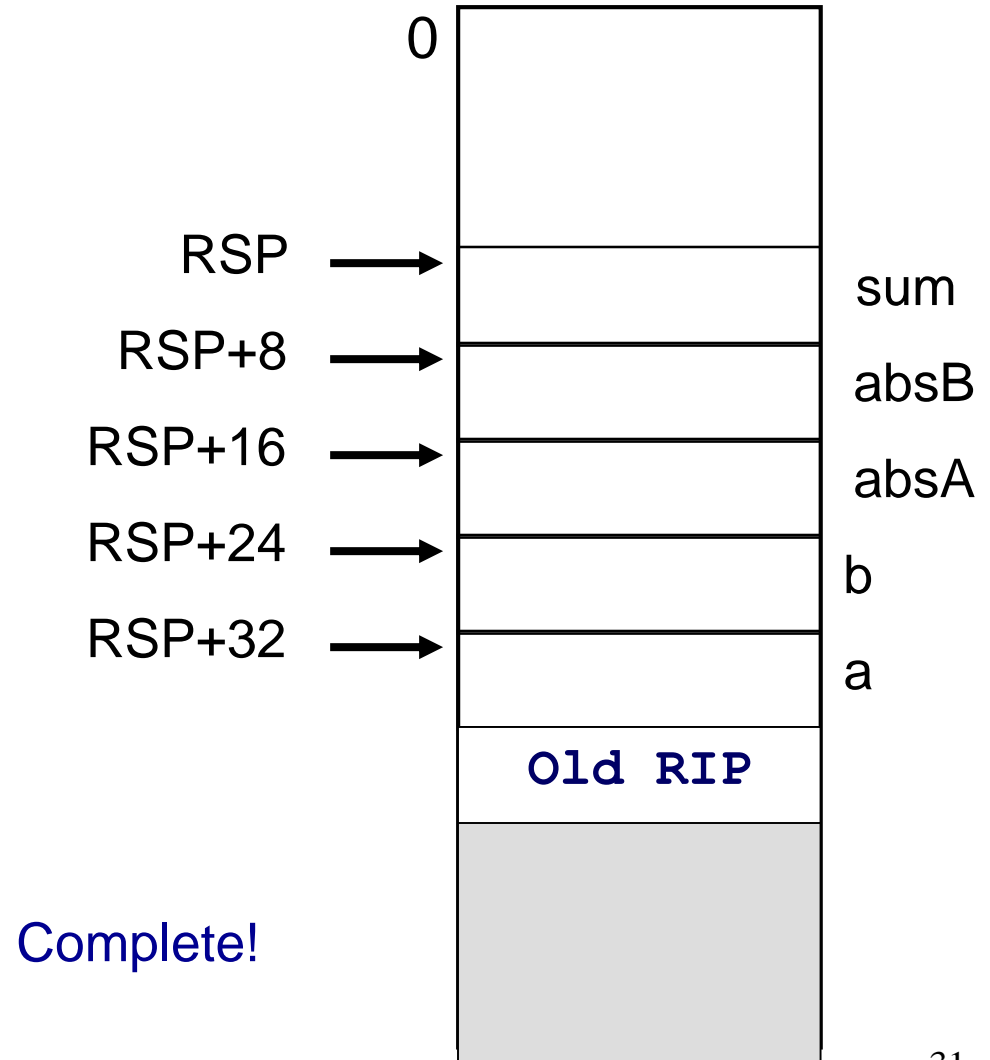



Agenda

Calling and returning

Passing arguments

Storing local variables

Returning a value

Optimization



Problem 5: Optimization

Observation: Accessing memory is expensive

- More expensive than accessing registers
- For efficiency, want to store parameters and local variables in registers (and not in memory) when possible

Observation: Registers are a finite resource

- In principle: Each function should have its own registers
- In reality: All functions share same small set of registers

Problem: How do caller and callee use same set of registers without interference?

- Callee may use register that the caller also is using
- When callee returns control to caller, old register contents may have been lost
- Caller function cannot continue where it left off

x86-64 Solution: Register Conventions



Callee-save registers

- RBX, RBP, R12, R13, R14, R15
- Callee function ***must preserve*** contents
- If necessary...
 - Callee saves to stack near beginning
 - Callee restores from stack near end

Caller-save registers

- RDI, RSI, RDX, RCX, R8, R9, RAX, R10, R11
- Callee function ***can change*** contents
- If necessary...
 - Caller saves to stack before call
 - Caller restores from stack after call



Running Example

Local variable handling in *unoptimized* version:

- At beginning, `absadd()` allocates space for local variables (`absA`, `absB`, `sum`) in stack
- Body of `absadd()` uses stack
- At end, `absadd()` pops local variables from stack

Local variable handling in *optimized* version:

- `absadd()` keeps local variables in R13, R14, R15
- Body of `absadd()` uses R13, R14, R15
- Must be careful:
 - `absadd()` cannot change contents of R13, R14, or R15
 - So `absadd()` must save R13, R14, and R15 near beginning, and restore near end



Running Example

```
# long absadd(long a, long b)
absadd:
    pushq %r13 # Save R13, use for absA
    pushq %r14 # Save R14, use for absB
    pushq %r15 # Save R15, use for sum

    # absA = labs(a)
    pushq %rsi # Save RSI
    call labs
    movq %rax, %r13
    popq %rsi # Restore RSI

    # absB += labs(b)
    movq %rsi, %rdi
    call labs
    movq %rax, %r14

    # sum = absA + absB
    movq %r13, %r15
    addq %r14, %r15

    # return sum
    movq %r15, %rax
    popq %r15 # Restore R15
    popq %r14 # Restore R14
    popq %r13 # Restore R13
    ret
```

absadd() stores local vars in R13, R14, R15, not in memory

absadd() cannot destroy contents of R13, R14, R15

So **absadd()** must save R13, R14, R15 near beginning and restore near end



Running Example

Parameter handling in *unoptimized* version:

- **absadd ()** accepts parameters (**a** and **b**) in RDI and RSI
- At beginning, **absadd ()** copies contents of RDI and RSI to stack
- Body of **absadd ()** uses stack
- At end, **absadd ()** pops parameters from stack

Parameter handling in *optimized* version:

- **absadd ()** accepts parameters (**a** and **b**) in RDI and RSI
- Body of **absadd ()** uses RDI and RSI
- Must be careful:
 - Call of **labs ()** could change contents of RDI and/or RSI
 - **absadd ()** must save contents of RDI and/or RSI before call of **labs ()**, and restore contents after call



Running Example

```
# long absadd(long a, long b)
absadd:
    pushq %r13 # Save R13, use for absA
    pushq %r14 # Save R14, use for absB
    pushq %r15 # Save R15, use for sum

    # absA = labs(a)
    pushq %rsi # Save RSI
    call labs
    movq %rax, %r13
    popq %rsi # Restore RSI

    # absB += labs(b)
    movq %rsi, %rdi
    call labs
    movq %rax, %r14

    # sum = absA + absB
    movq %r13, %r15
    addq %r14, %r15

    # return sum
    movq %r15, %rax
    popq %r15 # Restore R15
    popq %r14 # Restore R14
    popq %r13 # Restore R13
    ret
```

absadd () keeps a and b in RDI and RSI, not in memory

labs () can change RDI and/or RSI

absadd () must retain contents of RSI (value of b) across 1st call of labs()

So **absadd ()** must save RSI before call and restore RSI after call



Unoptimized vs. Optimized Patterns

Unoptimized pattern

- Parameters and local variables all in memory (stack)
- **Pro:** Always possible
- **Con:** Inefficient
- gcc compiler uses when invoked without `-O` option

Optimized pattern

- Parameters and local variables all in registers
- **Pro:** Efficient
- **Con:** Sometimes impossible
 - More than 6 local variables
 - Local variable is a structure or array
 - Need to pass address of parameter or local variable: `&foo`
- gcc compiler uses when invoked with `-O` option, when it can!

Hybrid Patterns



Hybrids are possible

- Example: Parameters in registers, Local variables in memory (stack)

Hybrids are error prone for humans

- Example (continued from previous)
 - Step 1: Access local variable ← local var is at stack offset X
 - Step 2: Push caller-save register
 - Step 3: Access local variable ← local var is at stack offset X+8!!!
 - Step 4: Call `labs()`
 - Step 6: Access local variable ← local var is at stack offset X+8!!!
 - Step 7: Pop caller-save register
 - Step 8: Access local variable ← local var is at stack offset X

Solution: set up stack frame immediately on function entry, then there are consistent offsets for variables in the frame

Summary



Function calls in x86-64 assembly language

Calling and returning

- `call` instruction pushes RIP onto stack and jumps
- `ret` instruction pops from stack to RIP

Passing arguments

- Caller copies args to caller-saved registers (in prescribed order)
- Unoptimized pattern:
 - Callee pushes args to stack
 - Callee uses args as positive offsets from RSP
 - Callee pops args from stack
- Optimized pattern:
 - Callee keeps args in caller-saved registers
 - Be careful!

Summary (cont.)



Storing local variables

- Unoptimized pattern:
 - Callee pushes local vars onto stack
 - Callee uses local vars as positive offsets from RSP
 - Callee pops local vars from stack
- Optimized pattern:
 - Callee keeps local vars in callee-saved registers
 - Be careful!

Returning values

- Callee places return value in RAX
- Caller accesses return value in RAX

Putting it all together

This would make an excellent exam question...



Add up the keys of a tree

```
struct tree {
    int key;
    struct tree *left;
    struct tree *right;
};

int sum (struct tree *t) {
    if (t==NULL)
        return 0;
    else return t->key +
               sum(t->left) +
               sum(t->right);
}
```

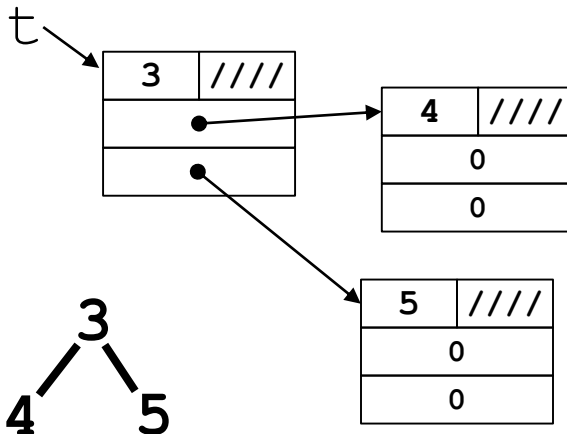

```
.text
.globl sum
sum:
# LOCAL VARIABLES:
# %r12=t, %r13d=partial sum
    pushq    %r12
    pushq    %r13
    movq     %rdi, %r12
    cmpq     $0, %r12
    jne     .L2
    movl     $0, %eax
    jmp     .L3
.L2:
    movl     0(%r12), %r13d
    movq     8(%r12), %rdi
    call    sum
    addl     %eax, %r13d
    movq     16(%r12), %rdi
    call    sum
    addl     %eax, %r13d
    movl     %r13d, %eax
.L3:
    popq     %r13
    popq     %r12
    ret
```