

Lecture 20

Deep Learning: Initialization, Architectures, Object Detection and Other Applications

COS 429: Computer Vision



Thanks: most of these slides shamelessly adapted from
Stanford CS231n: Convolutional Neural Networks for Visual Recognition
Fei-Fei Li, Andrej Karpathy, Justin Johnson
<http://cs231n.stanford.edu/>

Applications

Classification

mite	container ship	motor scooter	leopard
mite	container ship	motor scooter	leopard
black widow	lifeboat	go-kart	jaguar
cockroach	amphibian	moped	cheetah
tick	fireboat	bumper car	snow leopard
starfish	drilling platform	golfcart	Egyptian cat

grille	mushroom	cherry	Madagascar cat
convertible	agaric	dalmatian	squirrel monkey
grille	mushroom	grape	spider monkey
pickup	jelly fungus	elderberry	titi
beach wagon	gill fungus	ffordshire bullterrier	indri
fire engine	dead-man's-fingers	currant	howler monkey

Retrieval



[Krizhevsky 2012]

Applications

Detection

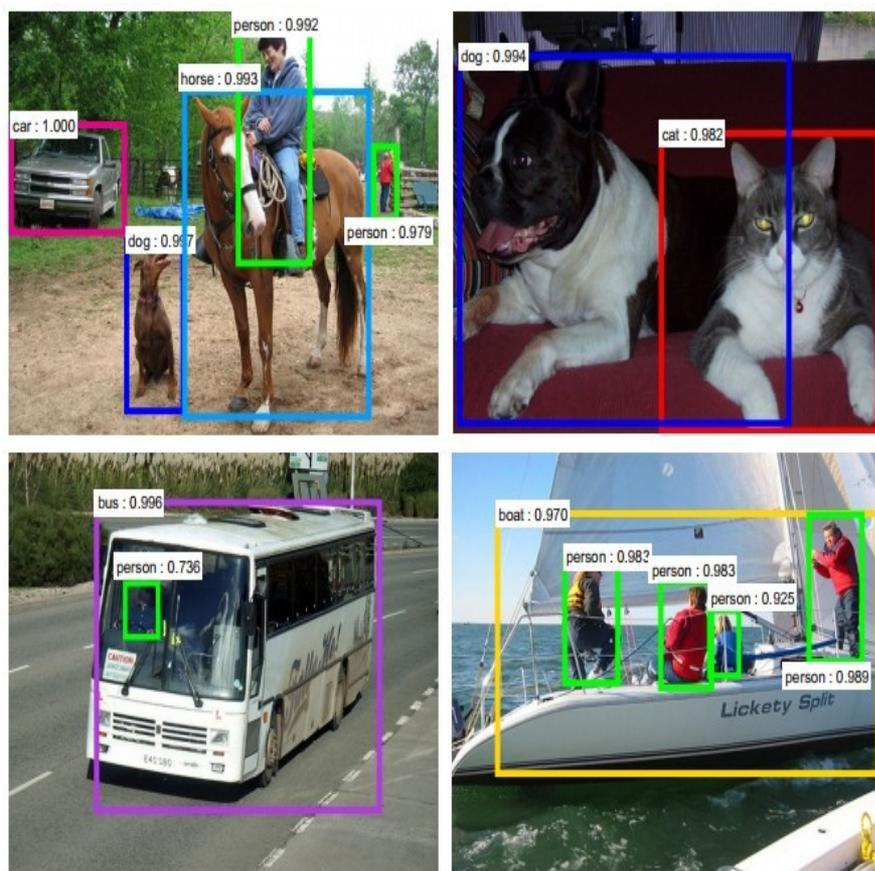

[Faster R-CNN: Ren, He, Girshick, Sun 2015]

Segmentation



[Farabet et al., 2012]

Applications

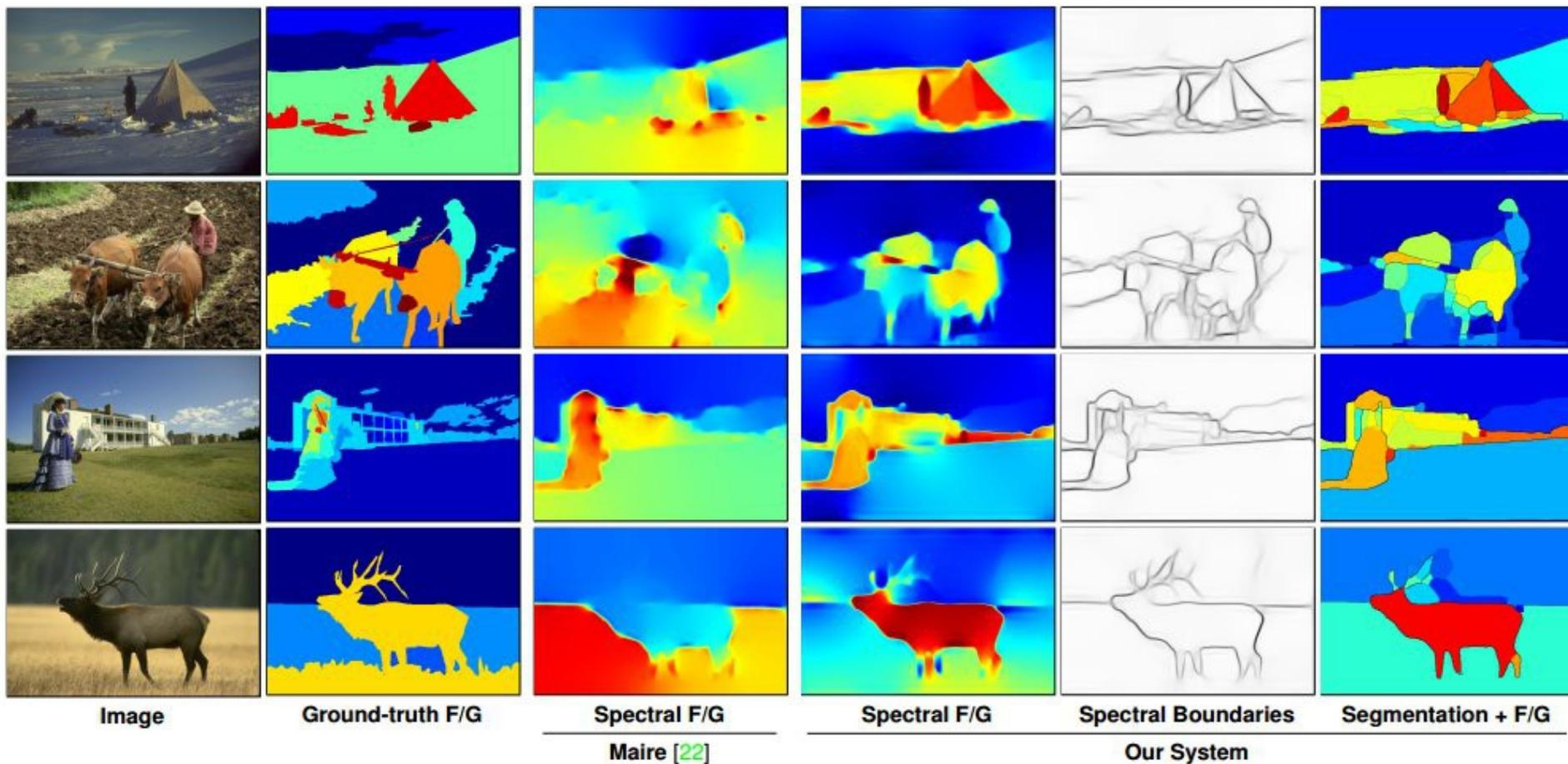

[Affinity CNN: Learning Pixel-Centric Pairwise Relations for Figure/Ground Embedding. Maire, Takuya Narihira, Yu 2016]

Applications

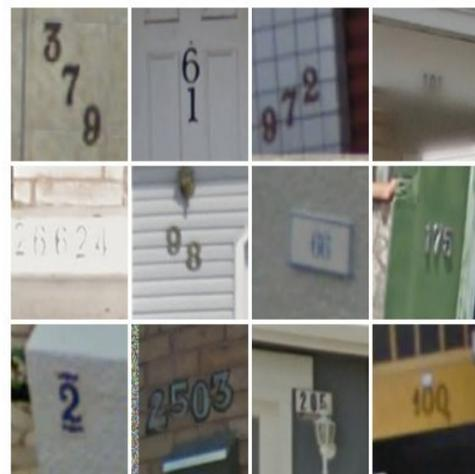
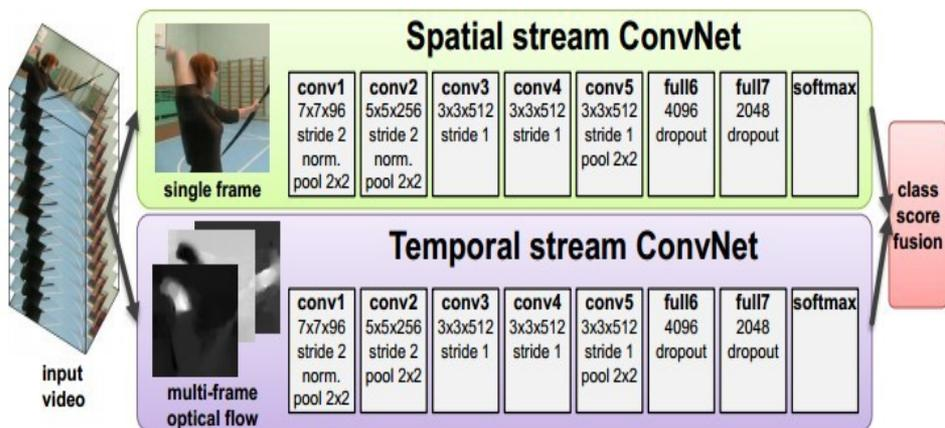
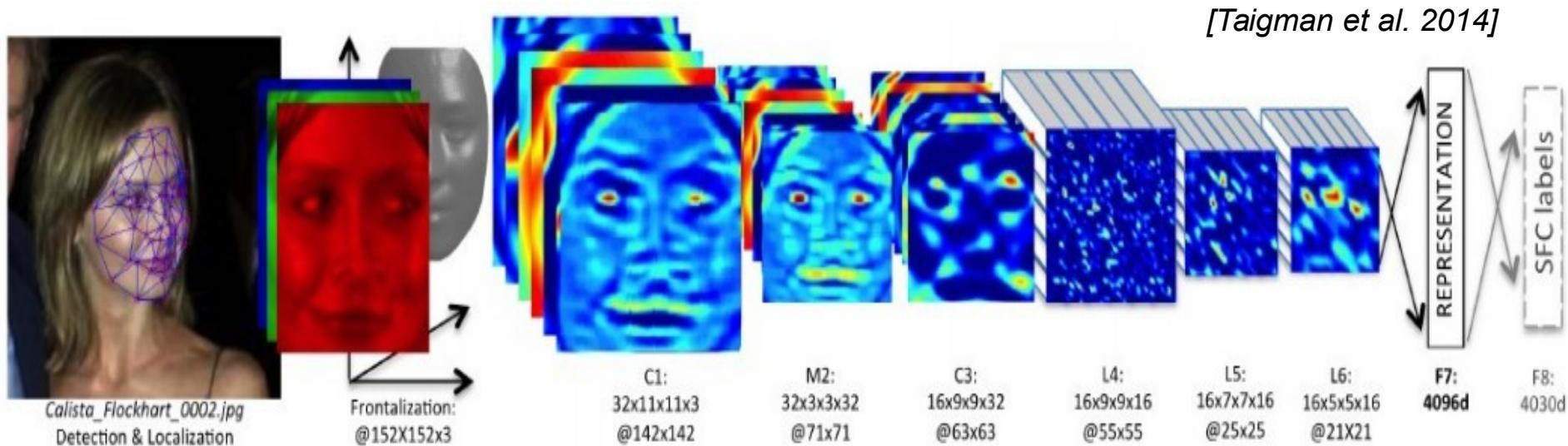

[Goodfellow 2014]

[Simonyan et al. 2014]

Applications



[Mnih 2013]

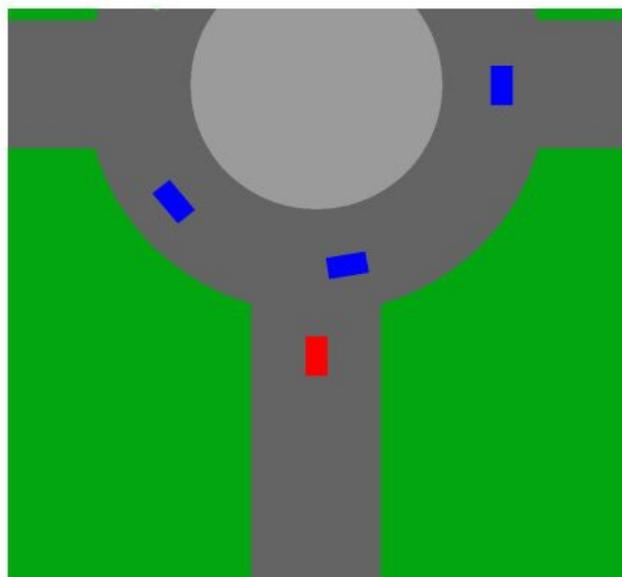

[Deep Reinforcement Learning for Driving Policy. Shwartz 2016]

Applications



Figure 10: Qualitative results of our method on the MPII, LSP and FLIC datasets respectively. We see that the method is able to handle non-standard poses and resolve ambiguities between symmetric parts for a variety of different relative camera views.

[Convolutional Pose Machines. Shih-En Wei, Varun Ramakrishna, Takeo Kanade, Yaser Sheikh]

Applications

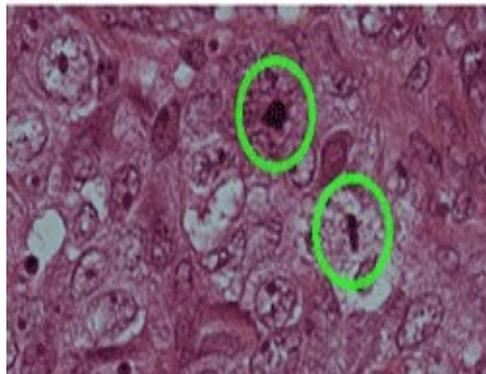
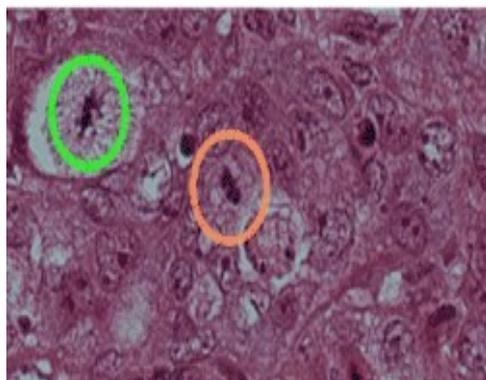

[Ciresan et al. 2013]



[Sermanet et al. 2011]
[Ciresan et al.]

Applications

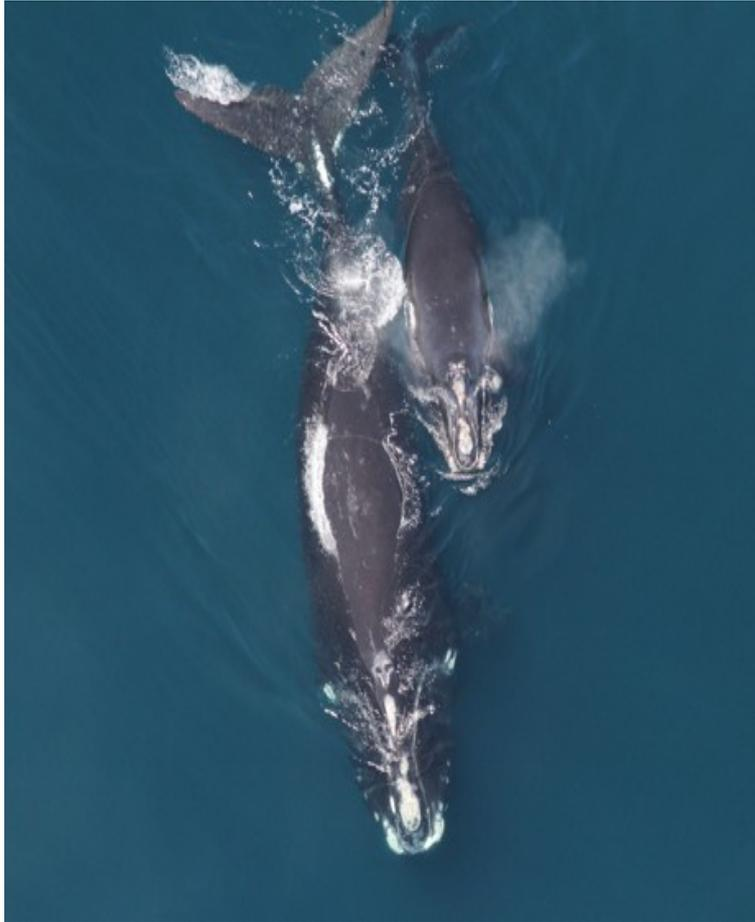

Whale recognition, Kaggle Challenge



Mnih and Hinton, 2010

Applications

I caught this movie on the Sci-Fi channel recently. It actually turned out to be pretty decent as far as B-list horror/suspense films go. **Two guys (one naive and one loud mouthed a **) take a road trip to stop a wedding but have the worst possible luck when a maniac in a freaky, make-shift tank/truck hybrid decides to play cat-and-mouse with them.** Things are further complicated when they pick up a ridiculously whorish hitchhiker. What makes this film unique is that the combination of comedy and terror actually work in this movie, unlike so many others. The two guys are likable enough and there are some good chase/suspense scenes. Nice pacing and comic timing make this movie more than passable for the horror/slasher buff. **Definitely worth checking out.**

I just saw this on a local independent station in the New York City area. **The cast showed promise but when I saw the director, George Cosmatos, I became suspicious. And sure enough, it was every bit as bad, every bit as pointless and stupid as every George Cosmatos movie I ever saw.** He's like a stupid man's Michael Bey – with all the awfulness that accolade promises. There's no point to the conspiracy, no burning issues that urge the conspirators on. We are left to ourselves to connect the dots from one bit of graffiti on various walls in the film to the next. Thus, the current budget crisis, the war in Iraq, Islamic extremism, the fate of social security, 47 million Americans without health care, stagnating wages, and the death of the middle class are all subsumed by the sheer terror of graffiti. A truly, stunningly idiotic film.

Graphics is far from the best part of the game. **This is the number one best TH game in the series.** Next to Underground. **It deserves strong love. It is an insane game.** There are massive levels, massive unlockable characters... it's just a massive game. **Waste your money on this game. This is the kind of money that is wasted properly.** And even though graphics suck, that doesn't make a game good. Actually, the graphics were good at the time. Today the graphics are crap. WHO CARES? As they say in Canada, This is the fun game, aye. (You get to go to Canada in THPS3) Well, I don't know if they say that, but they might. who knows. Well, Canadian people do. Wait a minute, I'm getting off topic. This game rocks. Buy it, play it, enjoy it, love it. It's PURE BRILLIANCE.

The first was good and original. I was a not bad horror/comedy movie. So I heard a second one was made and I had to watch it. What really makes this movie work is Judd Nelson's character and the sometimes clever script. **A pretty good script for a person who wrote the Final Destination films and the direction was okay.** Sometimes there's scenes where it looks like it was filmed using a home video camera with a grainy - look. Great made - for - TV movie. **It was worth the rental and probably worth buying just to get that nice eerie feeling and watch Judd Nelson's Stanley doing what he does best.** I suggest newcomers to watch the first one before watching the sequel, just so you'll have an idea what Stanley is like and get a little history background.

[Denil et al. 2014]

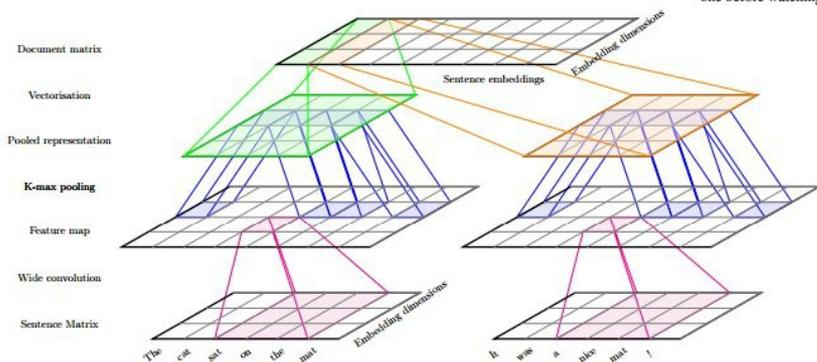

Figure 1: Word embeddings are concatenated into columns to form a sentence matrix. The ConvNet applies a cascade of convolution, pooling and nonlinearity operations to transform the projected sentence matrix into an embedding for the sentence. The sentence embeddings are then concatenated into columns to form a document matrix. The document model then applies its own cascade of convolution, pooling and nonlinearity operations to form an embedding for the whole document which is then fed into a softmax classifier.

Applications

Describes without errors



A person riding a motorcycle on a dirt road.

Describes with minor errors



Two dogs play in the grass.

Somewhat related to the image



A skateboarder does a trick on a ramp.

Unrelated to the image



A dog is jumping to catch a frisbee.



A group of young people playing a game of frisbee.



Two hockey players are fighting over the puck.



A little girl in a pink hat is blowing bubbles.



A refrigerator filled with lots of food and drinks.



A herd of elephants walking across a dry grass field.



A close up of a cat laying on a couch.



A red motorcycle parked on the side of the road.



A yellow school bus parked in a parking lot.

Image Captioning

[Vinyals et al., 2015]

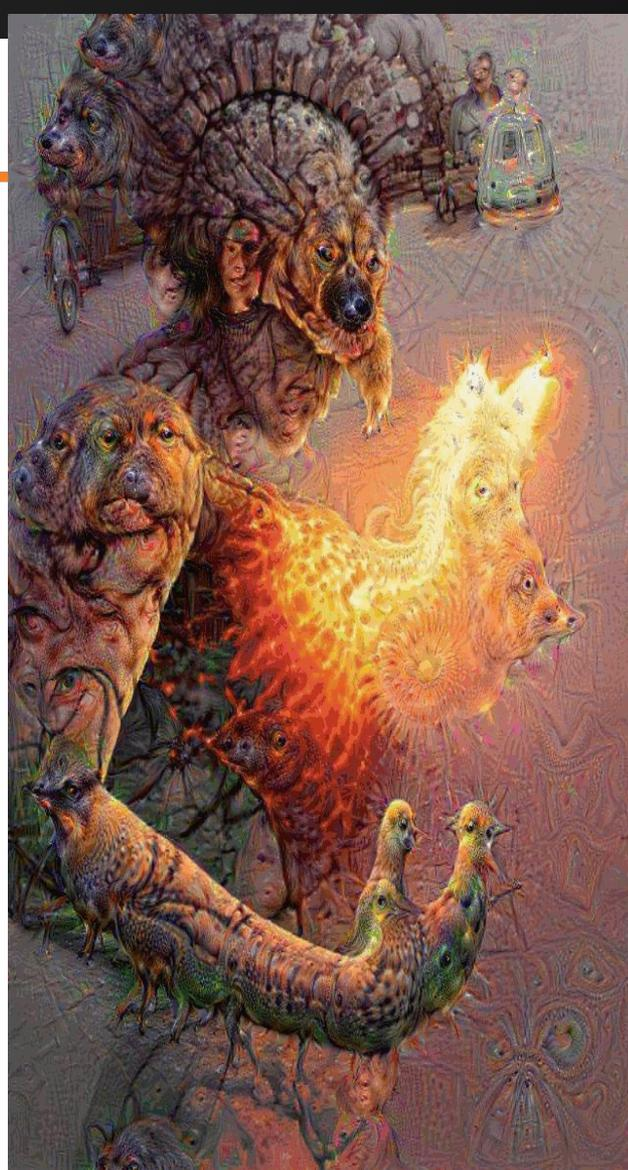
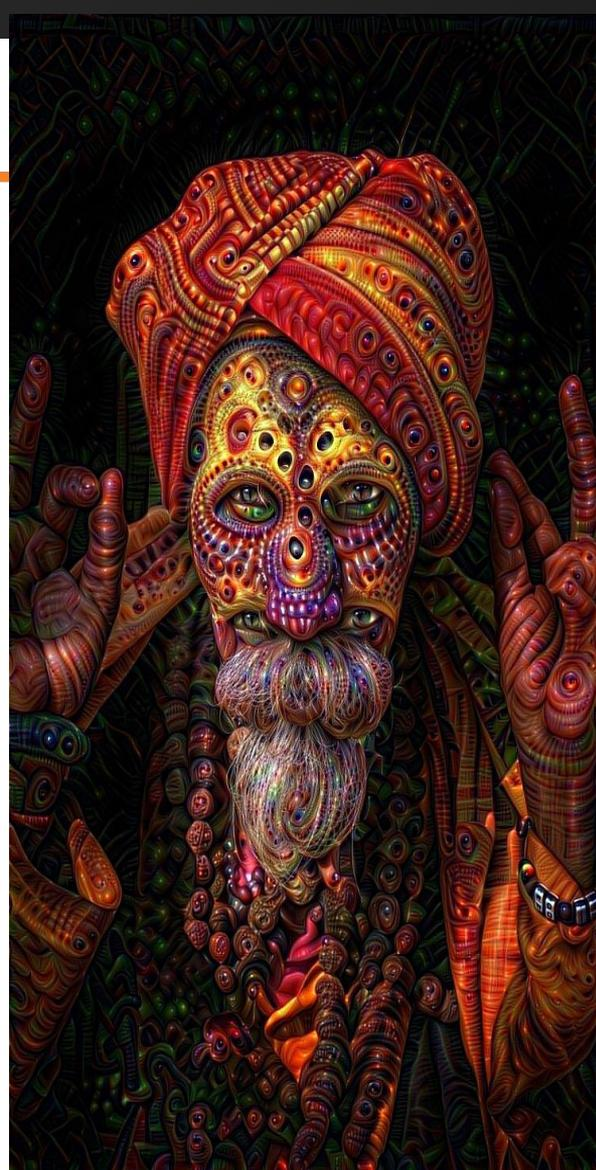

reddit.com/r/deepdream

DeepArt



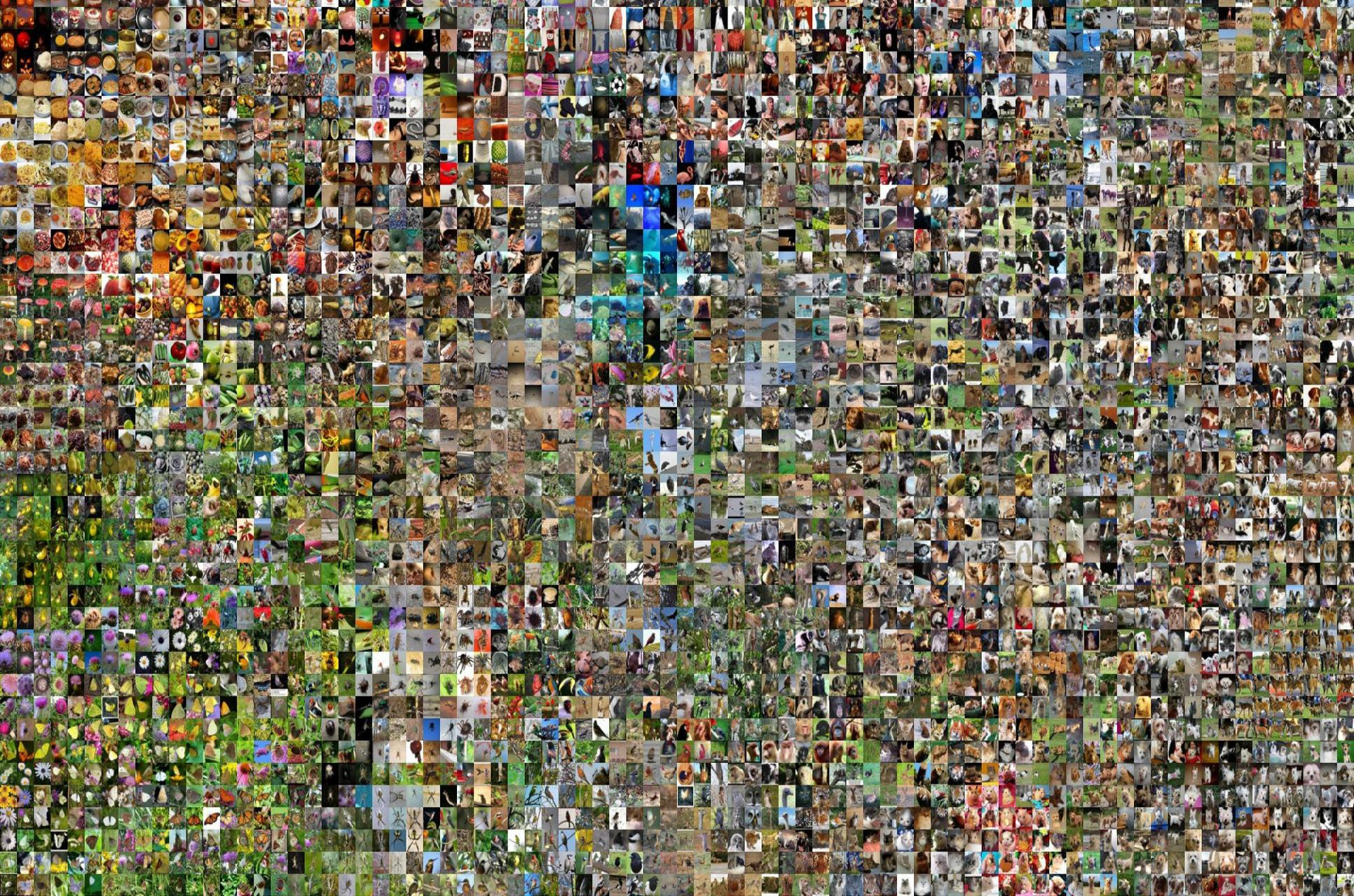

Applications

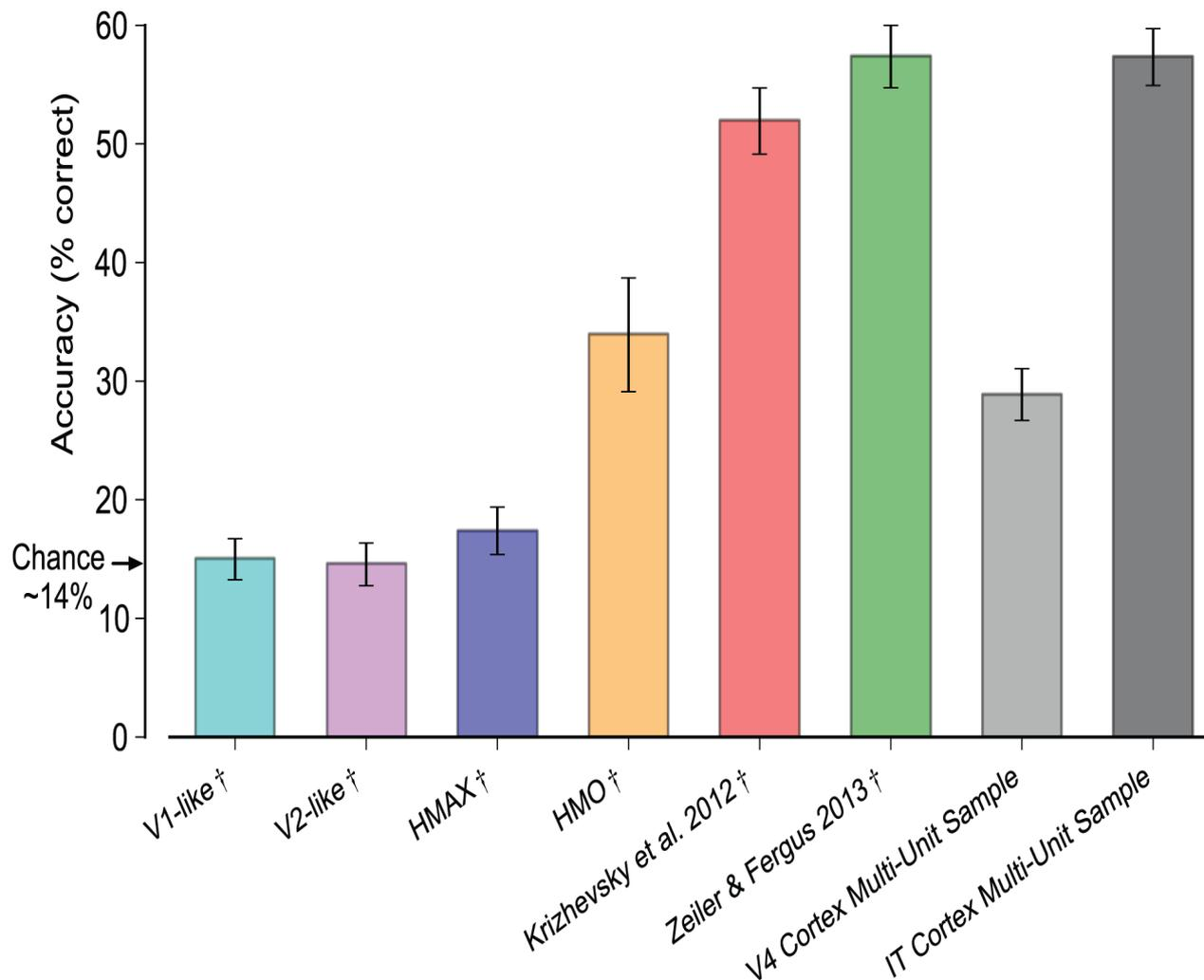

Deep Neural Networks Rival the Representation of Primate IT Cortex for Core Visual Object Recognition
[Cadieu et al., 2014]

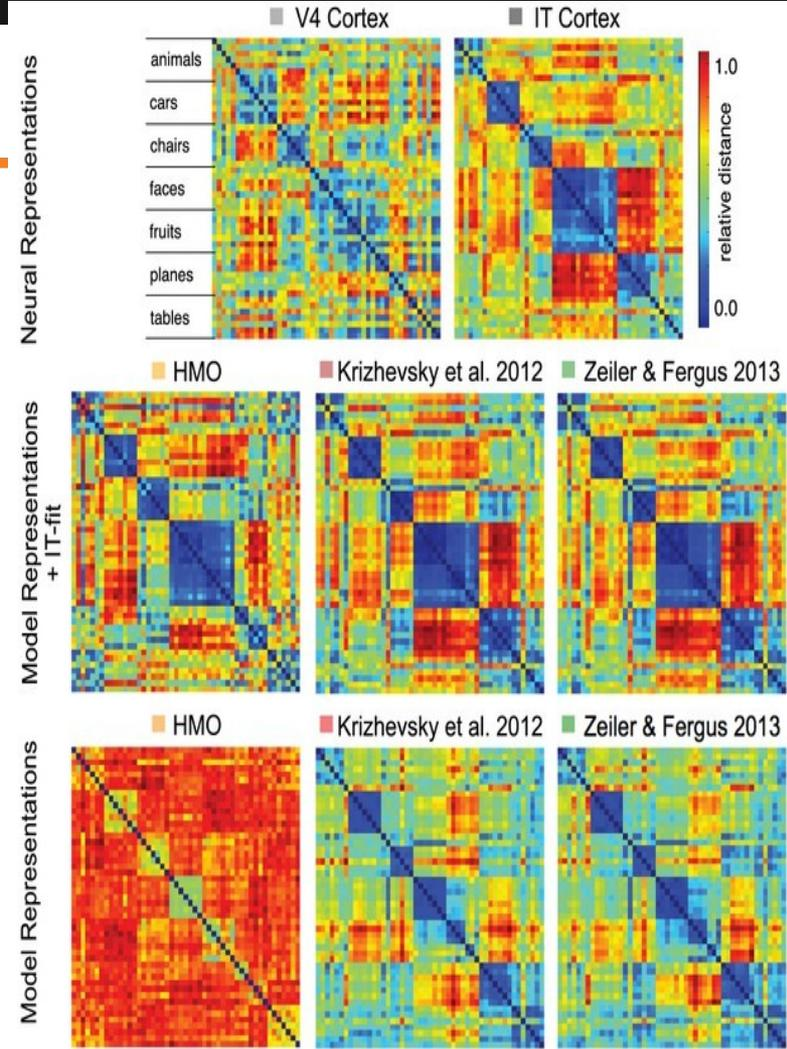
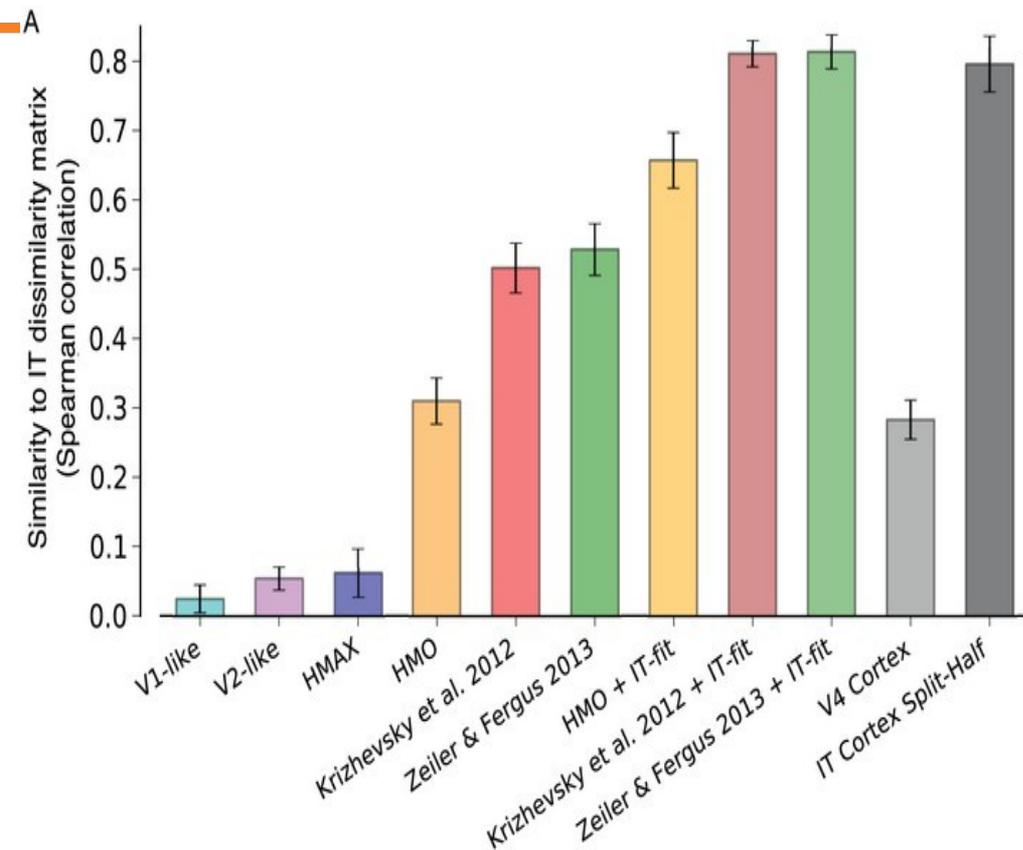

Deep Neural Networks Rival the Representation of Primate IT Cortex for Core Visual Object Recognition [Cadieu et al., 2014]

Case Study: AlexNet

[Krizhevsky et al. 2012]

Full (simplified) AlexNet architecture:

[227x227x3] INPUT

[55x55x96] **CONV1**: 96 11x11 filters at stride 4, pad 0

[27x27x96] **MAX POOL1**: 3x3 filters at stride 2

[27x27x96] **NORM1**: Normalization layer

[27x27x256] **CONV2**: 256 5x5 filters at stride 1, pad 2

[13x13x256] **MAX POOL2**: 3x3 filters at stride 2

[13x13x256] **NORM2**: Normalization layer

[13x13x384] **CONV3**: 384 3x3 filters at stride 1, pad 1

[13x13x384] **CONV4**: 384 3x3 filters at stride 1, pad 1

[13x13x256] **CONV5**: 256 3x3 filters at stride 1, pad 1

[6x6x256] **MAX POOL3**: 3x3 filters at stride 2

[4096] **FC6**: 4096 neurons

[4096] **FC7**: 4096 neurons

[1000] **FC8**: 1000 neurons (class scores)

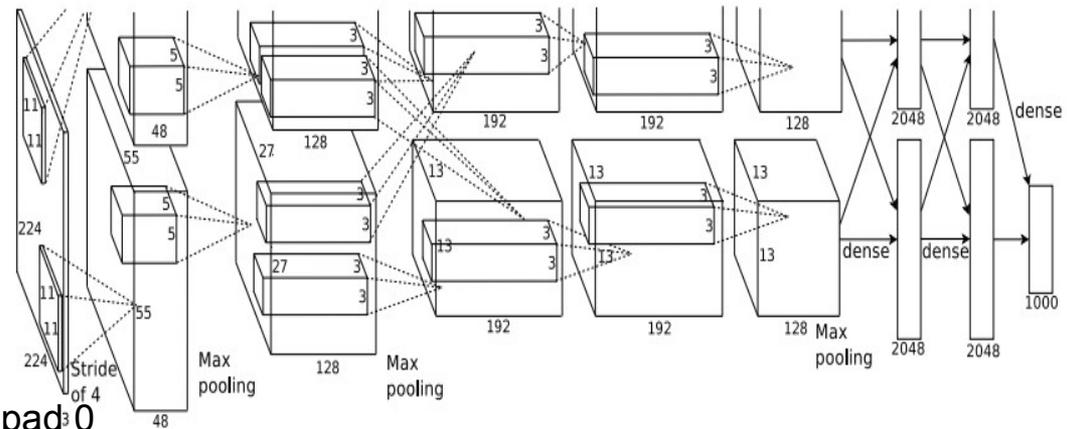

Details/Retrospectives:

- first use of ReLU
- used Norm layers (not common anymore)
- heavy data augmentation
- dropout 0.5
- batch size 128
- SGD Momentum 0.9
- Learning rate 1e-2, reduced by 10 manually when val accuracy plateaus
- L2 weight decay 5e-4
- 7 CNN ensemble: 18.2% -> 15.4%

Case Study: ZFNet

[Zeiler and Fergus, 2013]

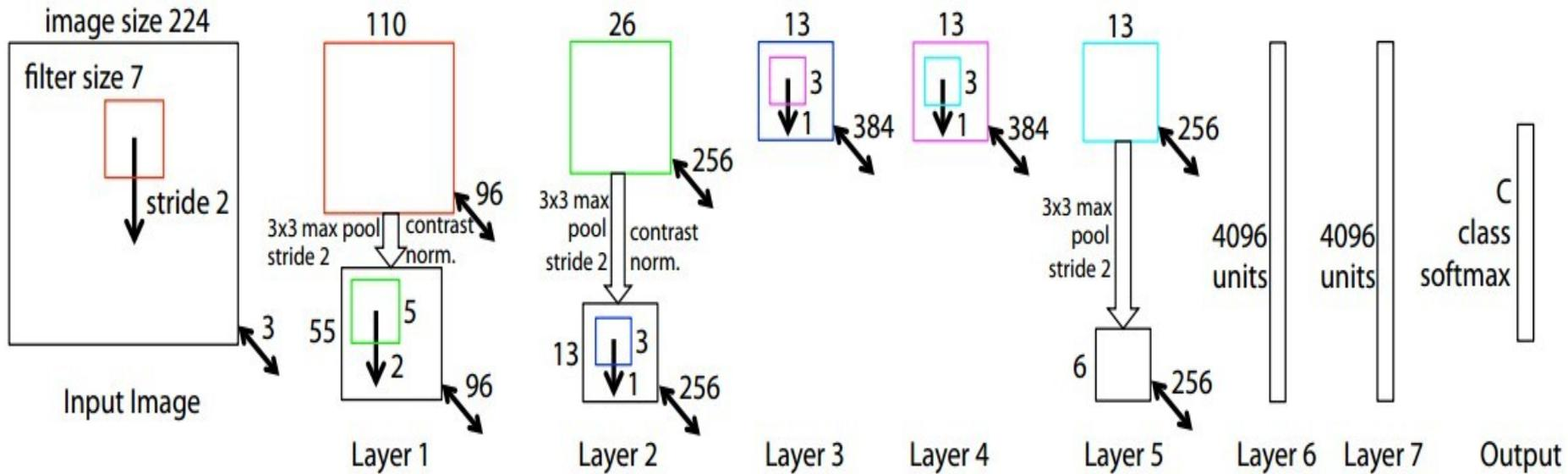

AlexNet but:

CONV1: change from (11x11 stride 4) to (7x7 stride 2)

CONV3,4,5: instead of 384, 384, 256 filters use 512, 1024, 512

ImageNet top 5 error: 15.4% -> 14.8%

Case Study: VGGNet

[Simonyan and Zisserman, 2014]

Only 3x3 CONV stride 1, pad 1
and 2x2 MAX POOL stride 2

best model

11.2% top 5 error in ILSVRC 2013

->

7.3% top 5 error

ConvNet Configuration					
A	A-LRN	B	C	D	E
11 weight layers	11 weight layers	13 weight layers	16 weight layers	16 weight layers	19 weight layers
input (224 × 224 RGB image)					
conv3-64	conv3-64 LRN	conv3-64 conv3-64	conv3-64 conv3-64	conv3-64 conv3-64	conv3-64 conv3-64
maxpool					
conv3-128	conv3-128	conv3-128 conv3-128	conv3-128 conv3-128	conv3-128 conv3-128	conv3-128 conv3-128
maxpool					
conv3-256 conv3-256	conv3-256 conv3-256	conv3-256 conv3-256	conv3-256 conv3-256 conv1-256	conv3-256 conv3-256 conv3-256	conv3-256 conv3-256 conv3-256 conv3-256
maxpool					
conv3-512 conv3-512	conv3-512 conv3-512	conv3-512 conv3-512	conv3-512 conv3-512 conv1-512	conv3-512 conv3-512 conv3-512	conv3-512 conv3-512 conv3-512 conv3-512
maxpool					
conv3-512 conv3-512	conv3-512 conv3-512	conv3-512 conv3-512	conv3-512 conv3-512 conv1-512	conv3-512 conv3-512 conv3-512	conv3-512 conv3-512 conv3-512 conv3-512
maxpool					
FC-4096					
FC-4096					
FC-1000					
soft-max					

Table 2: Number of parameters (in millions).

Network	A,A-LRN	B	C	D	E
Number of parameters	133	133	134	138	144

INPUT: [224x224x3] memory: $224*224*3=150K$ params: 0
 CONV3-64: [224x224x64] memory: $224*224*64=3.2M$ params: $(3*3*3)*64 = 1,728$
 CONV3-64: [224x224x64] memory: $224*224*64=3.2M$ params: $(3*3*64)*64 = 36,864$
 POOL2: [112x112x64] memory: $112*112*64=800K$ params: 0
 CONV3-128: [112x112x128] memory: $112*112*128=1.6M$ params: $(3*3*64)*128 = 73,728$
 CONV3-128: [112x112x128] memory: $112*112*128=1.6M$ params: $(3*3*128)*128 = 147,456$
 POOL2: [56x56x128] memory: $56*56*128=400K$ params: 0
 CONV3-256: [56x56x256] memory: $56*56*256=800K$ params: $(3*3*128)*256 = 294,912$
 CONV3-256: [56x56x256] memory: $56*56*256=800K$ params: $(3*3*256)*256 = 589,824$
 CONV3-256: [56x56x256] memory: $56*56*256=800K$ params: $(3*3*256)*256 = 589,824$
 POOL2: [28x28x256] memory: $28*28*256=200K$ params: 0
 CONV3-512: [28x28x512] memory: $28*28*512=400K$ params: $(3*3*256)*512 = 1,179,648$
 CONV3-512: [28x28x512] memory: $28*28*512=400K$ params: $(3*3*512)*512 = 2,359,296$
 CONV3-512: [28x28x512] memory: $28*28*512=400K$ params: $(3*3*512)*512 = 2,359,296$
 POOL2: [14x14x512] memory: $14*14*512=100K$ params: 0
 CONV3-512: [14x14x512] memory: $14*14*512=100K$ params: $(3*3*512)*512 = 2,359,296$
 CONV3-512: [14x14x512] memory: $14*14*512=100K$ params: $(3*3*512)*512 = 2,359,296$
 CONV3-512: [14x14x512] memory: $14*14*512=100K$ params: $(3*3*512)*512 = 2,359,296$
 POOL2: [7x7x512] memory: $7*7*512=25K$ params: 0
 FC: [1x1x4096] memory: 4096 params: $7*7*512*4096 = 102,760,448$
 FC: [1x1x4096] memory: 4096 params: $4096*4096 = 16,777,216$
 FC: [1x1x1000] memory: 1000 params: $4096*1000 = 4,096,000$

TOTAL memory: 24M * 4 bytes \sim 93MB / image (only forward! \sim *2 for bwd)

TOTAL params: 138M parameters

ConvNet Configuration			
B	C	D	
13 weight layers	16 weight layers	16 weight layers	19
put (224 × 224 RGB image)			
conv3-64	conv3-64	conv3-64	cc
conv3-64	conv3-64	conv3-64	cc
maxpool			
conv3-128	conv3-128	conv3-128	co
conv3-128	conv3-128	conv3-128	co
maxpool			
conv3-256	conv3-256	conv3-256	co
conv3-256	conv3-256	conv3-256	co
	conv1-256	conv3-256	co
			co
maxpool			
conv3-512	conv3-512	conv3-512	co
conv3-512	conv3-512	conv3-512	co
	conv1-512	conv3-512	co
			co
maxpool			
conv3-512	conv3-512	conv3-512	co
conv3-512	conv3-512	conv3-512	co
	conv1-512	conv3-512	co
			co
maxpool			
FC-4096			
FC-4096			
FC-1000			
soft-max			

(not counting biases)

INPUT: [224x224x3] memory: $224*224*3=150K$ params: 0
CONV3-64: [224x224x64] memory: $224*224*64=3.2M$ params: $(3*3*3)*64 = 1,728$
CONV3-64: [224x224x64] memory: $224*224*64=3.2M$ params: $(3*3*64)*64 = 36,864$
POOL2: [112x112x64] memory: $112*112*64=800K$ params: 0
CONV3-128: [112x112x128] memory: $112*112*128=1.6M$ params: $(3*3*64)*128 = 73,728$
CONV3-128: [112x112x128] memory: $112*112*128=1.6M$ params: $(3*3*128)*128 = 147,456$
POOL2: [56x56x128] memory: $56*56*128=400K$ params: 0
CONV3-256: [56x56x256] memory: $56*56*256=800K$ params: $(3*3*128)*256 = 294,912$
CONV3-256: [56x56x256] memory: $56*56*256=800K$ params: $(3*3*256)*256 = 589,824$
CONV3-256: [56x56x256] memory: $56*56*256=800K$ params: $(3*3*256)*256 = 589,824$
POOL2: [28x28x256] memory: $28*28*256=200K$ params: 0
CONV3-512: [28x28x512] memory: $28*28*512=400K$ params: $(3*3*256)*512 = 1,179,648$
CONV3-512: [28x28x512] memory: $28*28*512=400K$ params: $(3*3*512)*512 = 2,359,296$
CONV3-512: [28x28x512] memory: $28*28*512=400K$ params: $(3*3*512)*512 = 2,359,296$
POOL2: [14x14x512] memory: $14*14*512=100K$ params: 0
CONV3-512: [14x14x512] memory: $14*14*512=100K$ params: $(3*3*512)*512 = 2,359,296$
CONV3-512: [14x14x512] memory: $14*14*512=100K$ params: $(3*3*512)*512 = 2,359,296$
CONV3-512: [14x14x512] memory: $14*14*512=100K$ params: $(3*3*512)*512 = 2,359,296$
POOL2: [7x7x512] memory: $7*7*512=25K$ params: 0
FC: [1x1x4096] memory: 4096 params: $7*7*512*4096 = 102,760,448$
FC: [1x1x4096] memory: 4096 params: $4096*4096 = 16,777,216$
FC: [1x1x1000] memory: 1000 params: $4096*1000 = 4,096,000$

Note:

Most memory is in early CONV

Most params are in late FC

TOTAL memory: $24M * 4 \text{ bytes} \approx 93MB / \text{image}$ (only forward! $\sim *2$ for bwd)

TOTAL params: 138M parameters

Step 1: Preprocess the data

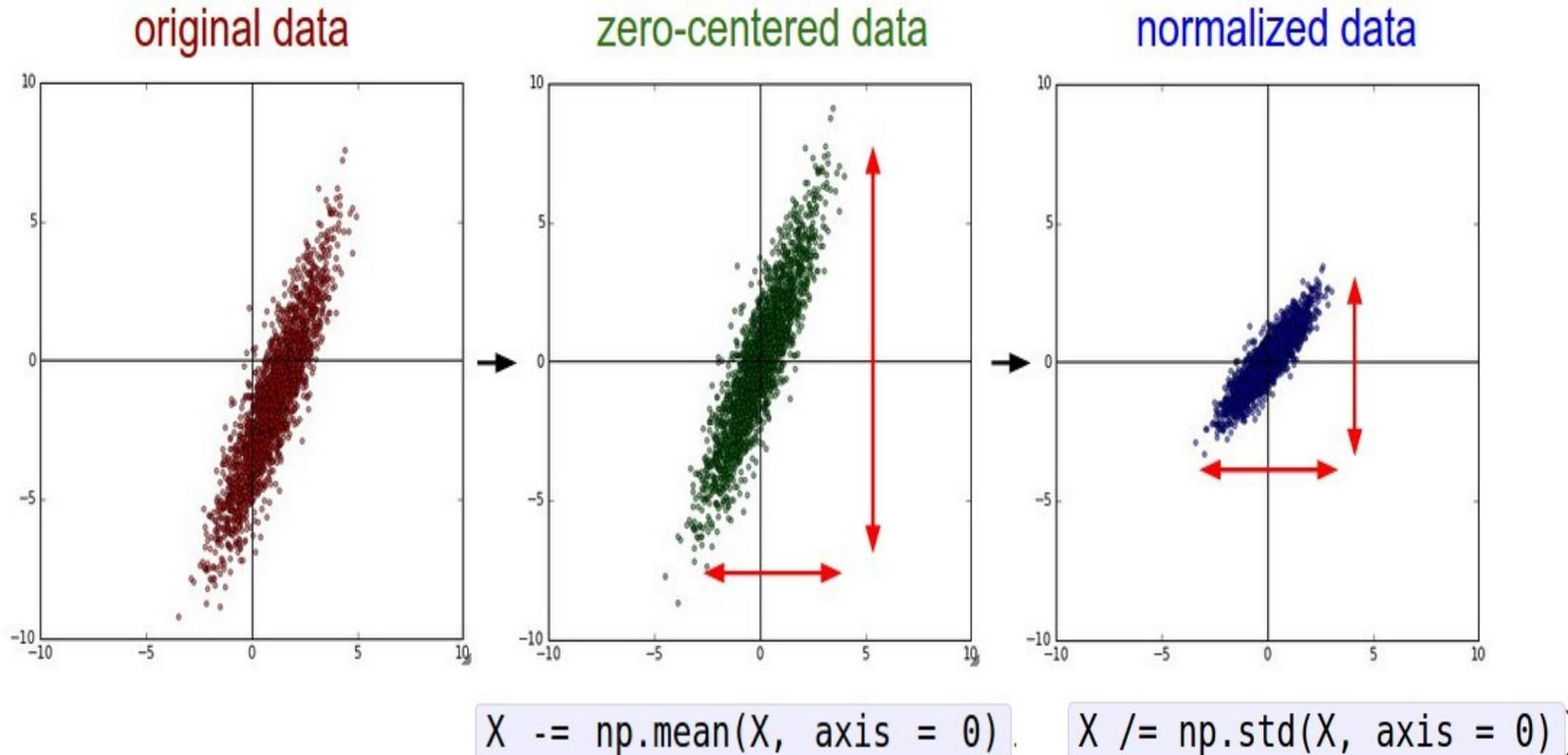

(Assume X [NxD] is data matrix,
each example in a row)

TLDR: In practice for Images: center only

e.g. consider CIFAR-10 example with [32,32,3] images

- Subtract the mean image (e.g. AlexNet)
(mean image = [32,32,3] array)
- Subtract per-channel mean (e.g. VGGNet)
(mean along each channel = 3 numbers)

Not common to
normalize variance, to do
PCA or whitening

- Q: what happens when $W=0$ init is used?

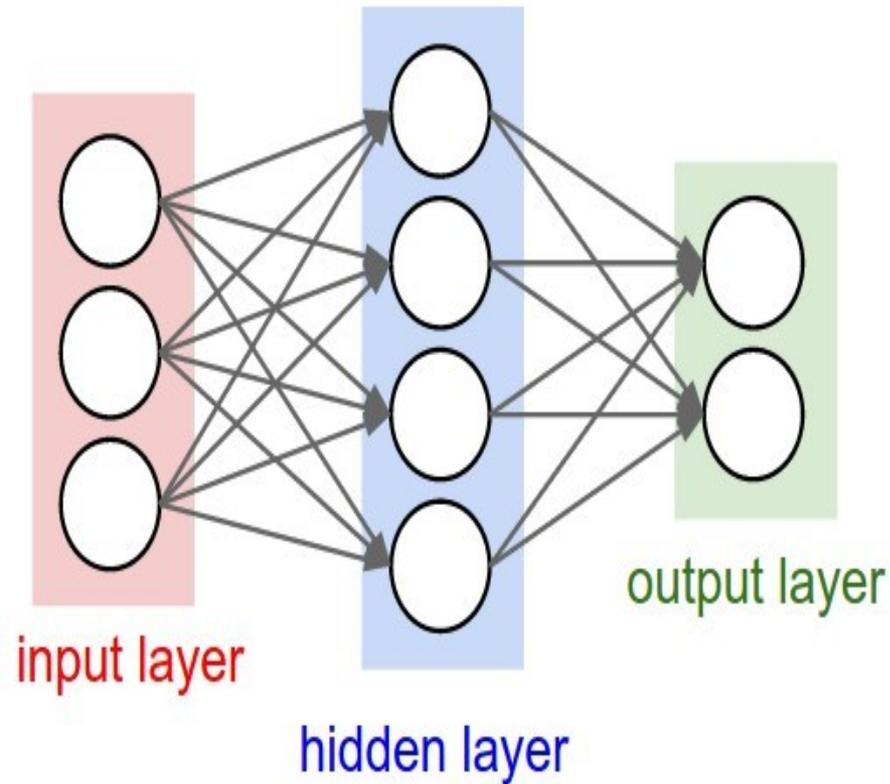

- First idea: **Small random numbers**

(gaussian with zero mean and $1e-2$ standard deviation)

```
W = 0.01* np.random.randn(D,H)
```

- First idea: **Small random numbers**
(gaussian with zero mean and $1e-2$ standard deviation)

$$W = 0.01 * \text{np.random.randn}(D, H)$$

Works ~okay for small networks, but can lead to non-homogeneous distributions of activations across the layers of a network.

Lets look at some activation statistics

E.g. 10-layer net with
500 neurons on each
layer, using tanh non-
linearities, and
initializing as
described in last slide.

```
# assume some unit gaussian 10-D input data
D = np.random.randn(1000, 500)
hidden_layer_sizes = [500]*10
nonlinearities = ['tanh']*len(hidden_layer_sizes)
```

```
act = {'relu':lambda x:np.maximum(0,x), 'tanh':lambda x:np.tanh(x)}
Hs = {}
for i in xrange(len(hidden_layer_sizes)):
    X = D if i == 0 else Hs[i-1] # input at this layer
    fan_in = X.shape[1]
    fan_out = hidden_layer_sizes[i]
    W = np.random.randn(fan_in, fan_out) * 0.01 # layer initialization

    H = np.dot(X, W) # matrix multiply
    H = act[nonlinearities[i]](H) # nonlinearity
    Hs[i] = H # cache result on this layer
```

```
# look at distributions at each layer
print 'input layer had mean %f and std %f' % (np.mean(D), np.std(D))
layer_means = [np.mean(H) for i,H in Hs.iteritems()]
layer_stds = [np.std(H) for i,H in Hs.iteritems()]
for i,H in Hs.iteritems():
    print 'hidden layer %d had mean %f and std %f' % (i+1, layer_means[i], layer_stds[i])

# plot the means and standard deviations
plt.figure()
plt.subplot(121)
plt.plot(Hs.keys(), layer_means, 'ob-')
plt.title('layer mean')
plt.subplot(122)
plt.plot(Hs.keys(), layer_stds, 'or-')
plt.title('layer std')

# plot the raw distributions
plt.figure()
for i,H in Hs.iteritems():
    plt.subplot(1,len(Hs),i+1)
    plt.hist(H.ravel(), 30, range=(-1,1))
```

input layer had mean 0.000927 and std 0.998388
 hidden layer 1 had mean -0.000117 and std 0.213081
 hidden layer 2 had mean -0.000001 and std 0.047551
 hidden layer 3 had mean -0.000002 and std 0.010630
 hidden layer 4 had mean 0.000001 and std 0.002378
 hidden layer 5 had mean 0.000002 and std 0.000532
 hidden layer 6 had mean -0.000000 and std 0.000119
 hidden layer 7 had mean 0.000000 and std 0.000026
 hidden layer 8 had mean -0.000000 and std 0.000006
 hidden layer 9 had mean 0.000000 and std 0.000001
 hidden layer 10 had mean -0.000000 and std 0.000000

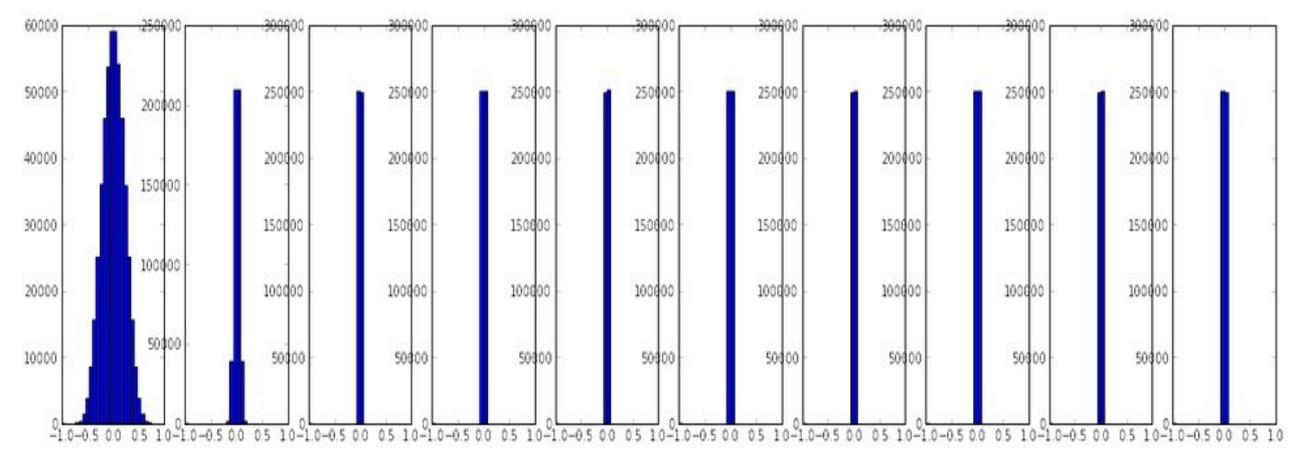
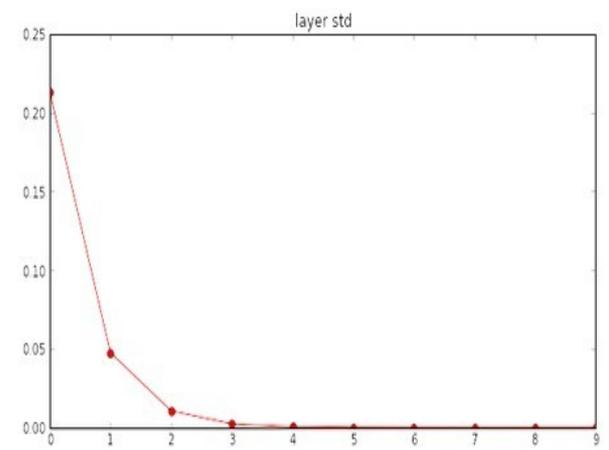
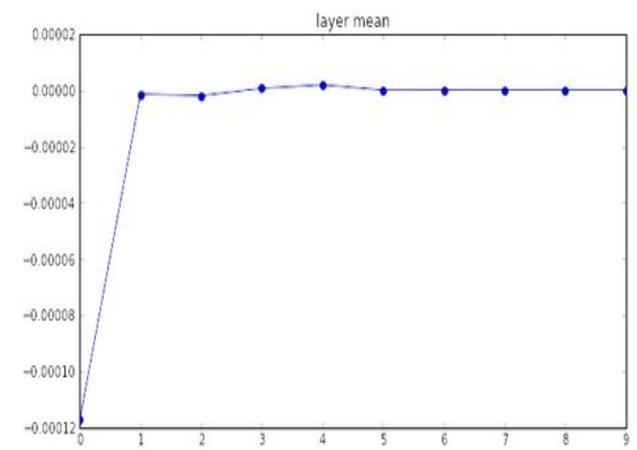

input layer had mean 0.000927 and std 0.998388
 hidden layer 1 had mean -0.000117 and std 0.213081
 hidden layer 2 had mean -0.000001 and std 0.047551
 hidden layer 3 had mean -0.000002 and std 0.010630
 hidden layer 4 had mean 0.000001 and std 0.002378
 hidden layer 5 had mean 0.000002 and std 0.000532
 hidden layer 6 had mean -0.000000 and std 0.000119
 hidden layer 7 had mean 0.000000 and std 0.000026
 hidden layer 8 had mean -0.000000 and std 0.000006
 hidden layer 9 had mean 0.000000 and std 0.000001
 hidden layer 10 had mean -0.000000 and std 0.000000

All activations become zero!

Q: think about the backward pass.
 What do the gradients look like?

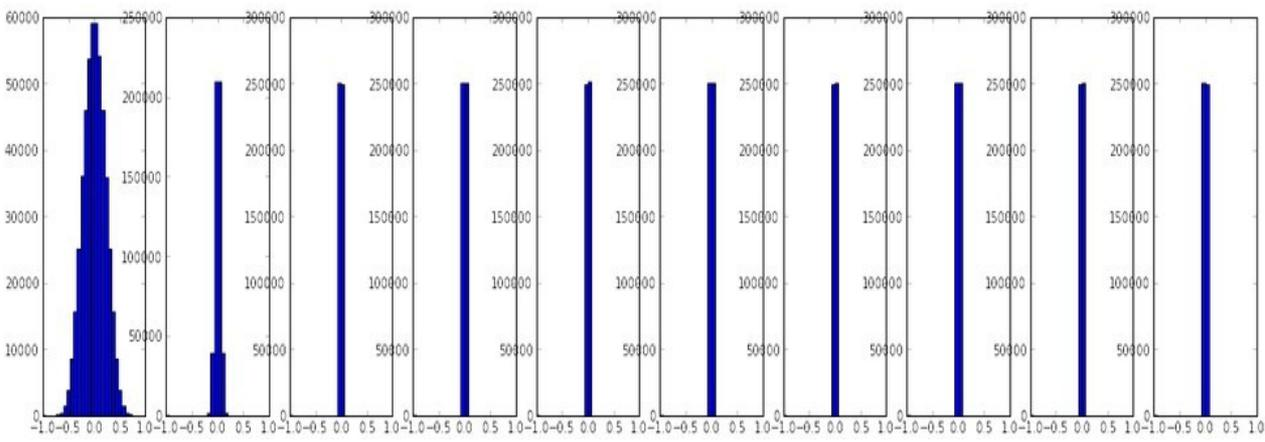
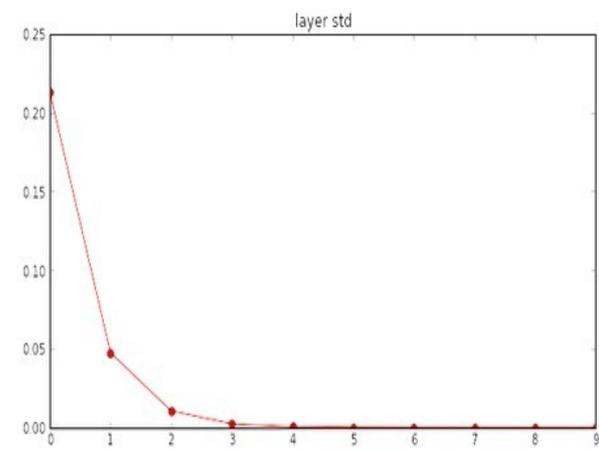
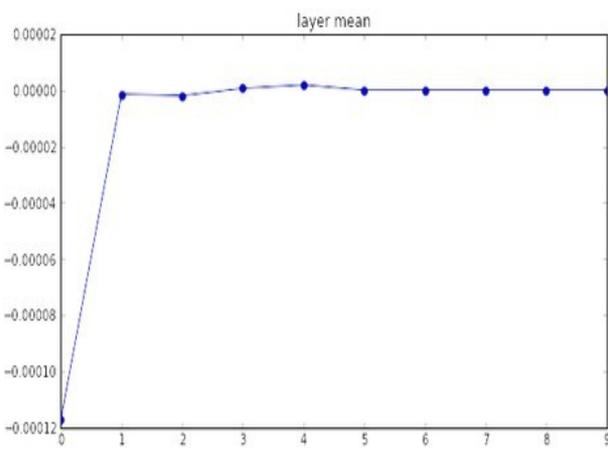

Hint: think about backward pass for a $W \cdot X$ gate.

```
W = np.random.randn(fan_in, fan_out) * 1.0 # layer initialization
```

input layer had mean 0.001800 and std 1.001311
hidden layer 1 had mean -0.000430 and std 0.981879
hidden layer 2 had mean -0.000849 and std 0.981649
hidden layer 3 had mean 0.000566 and std 0.981601
hidden layer 4 had mean 0.000483 and std 0.981755
hidden layer 5 had mean -0.000682 and std 0.981614
hidden layer 6 had mean -0.000401 and std 0.981560
hidden layer 7 had mean -0.000237 and std 0.981520
hidden layer 8 had mean -0.000448 and std 0.981913
hidden layer 9 had mean -0.000899 and std 0.981728
hidden layer 10 had mean 0.000584 and std 0.981736

*1.0 instead of *0.01

Almost all neurons
~~completely~~
saturated, either -1
and 1. Gradients
will be all zero.

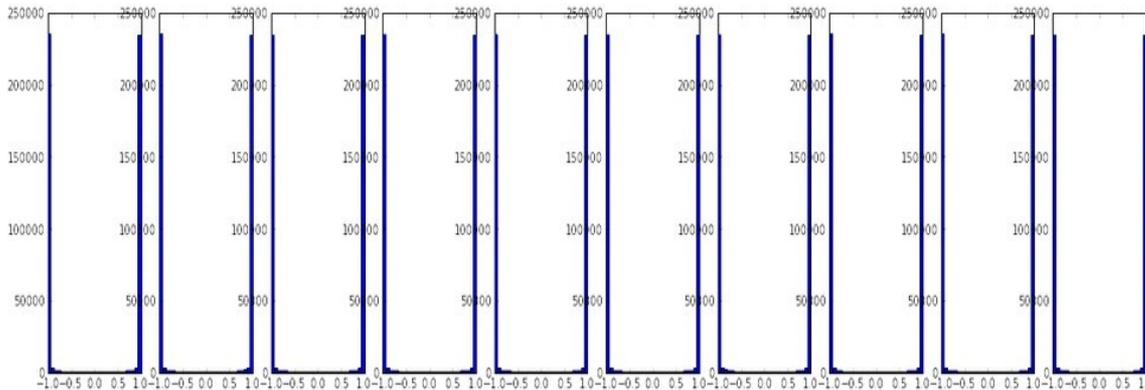
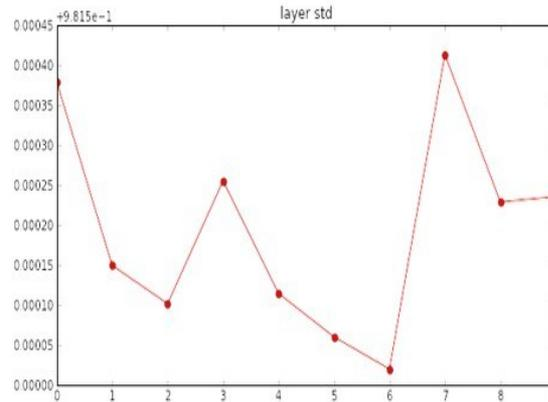
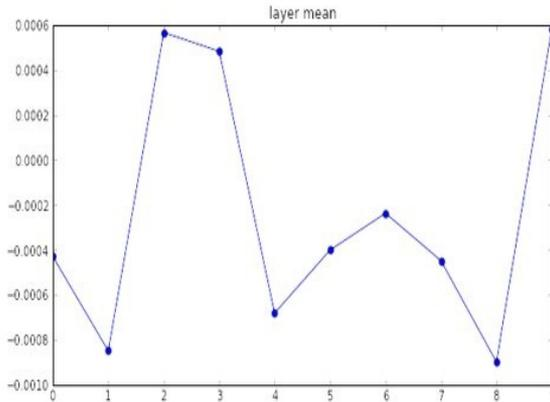

input layer had mean 0.001800 and std 1.001311
 hidden layer 1 had mean 0.001198 and std 0.627953
 hidden layer 2 had mean -0.000175 and std 0.486051
 hidden layer 3 had mean 0.000055 and std 0.407723
 hidden layer 4 had mean -0.000306 and std 0.357108
 hidden layer 5 had mean 0.000142 and std 0.320917
 hidden layer 6 had mean -0.000389 and std 0.292116
 hidden layer 7 had mean -0.000228 and std 0.273387
 hidden layer 8 had mean -0.000291 and std 0.254935
 hidden layer 9 had mean 0.000361 and std 0.239266
 hidden layer 10 had mean 0.000139 and std 0.228008

`W = np.random.randn(fan_in, fan_out) / np.sqrt(fan_in) # layer initialization`

“Xavier initialization” [Glorot et al., 2010]

Reasonable initialization.
 (Mathematical derivation
 assumes linear activations)

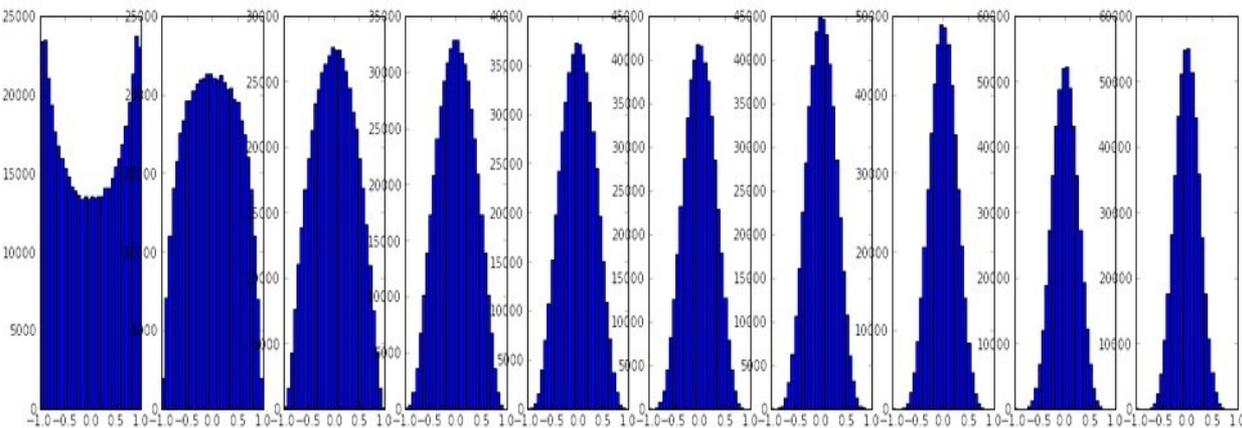
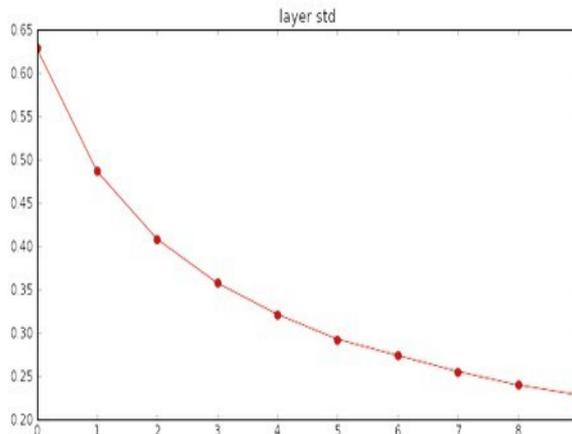
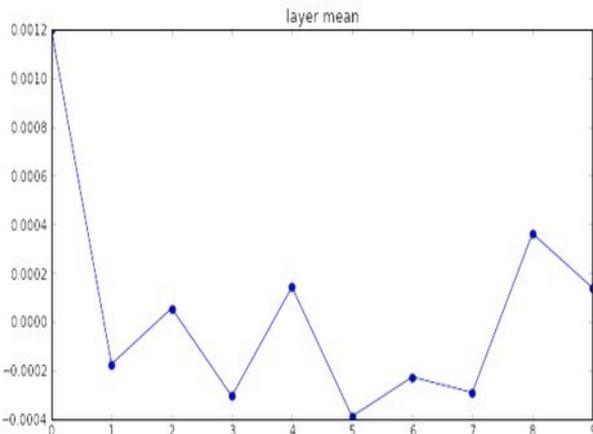

```

input layer had mean 0.000501 and std 0.999444
hidden layer 1 had mean 0.398623 and std 0.582273
hidden layer 2 had mean 0.272352 and std 0.403795
hidden layer 3 had mean 0.186076 and std 0.276912
hidden layer 4 had mean 0.136442 and std 0.198685
hidden layer 5 had mean 0.099568 and std 0.140299
hidden layer 6 had mean 0.072234 and std 0.103280
hidden layer 7 had mean 0.049775 and std 0.072748
hidden layer 8 had mean 0.035138 and std 0.051572
hidden layer 9 had mean 0.025404 and std 0.038583
hidden layer 10 had mean 0.018408 and std 0.026076

```

```

W = np.random.randn(fan_in, fan_out) / np.sqrt(fan_in) # layer initialization

```

but when using the ReLU nonlinearity it breaks.

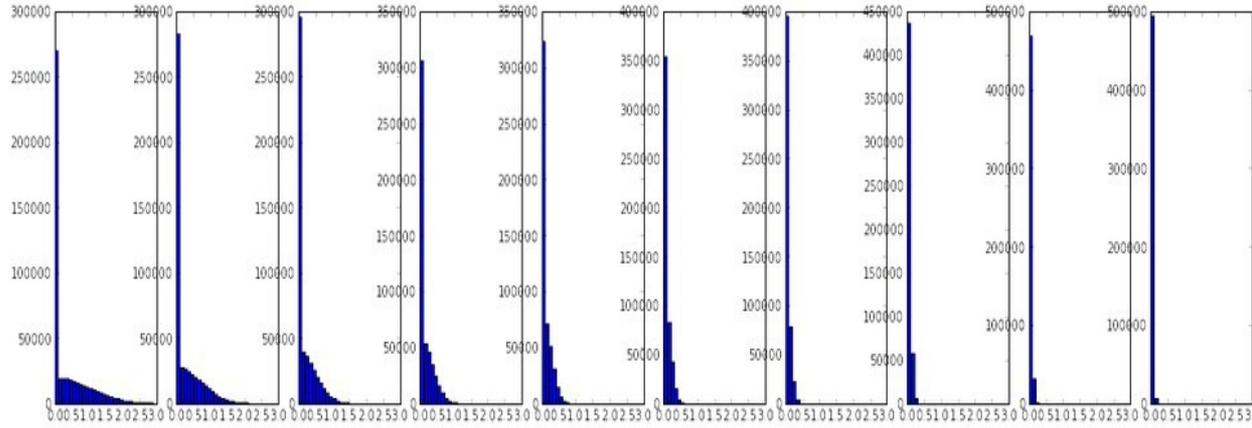
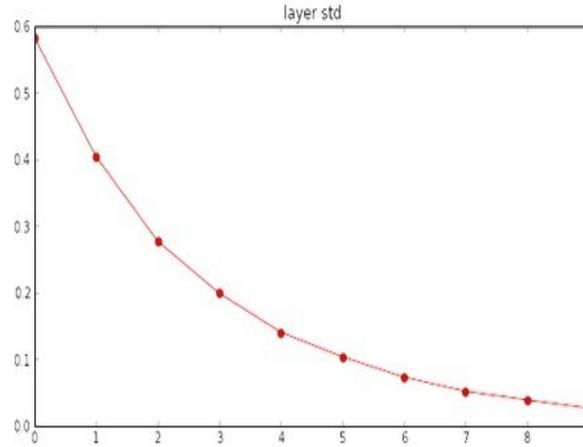
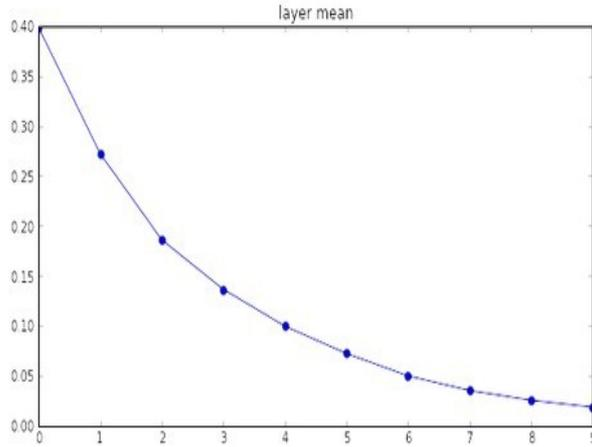

```
W = np.random.randn(fan_in, fan_out) / np.sqrt(fan_in/2) # layer initialization
```

input layer had mean 0.000501 and std 0.999444
hidden layer 1 had mean 0.562488 and std 0.825232
hidden layer 2 had mean 0.553614 and std 0.827835
hidden layer 3 had mean 0.545867 and std 0.813855
hidden layer 4 had mean 0.565396 and std 0.826902
hidden layer 5 had mean 0.547678 and std 0.834092
hidden layer 6 had mean 0.587103 and std 0.860035
hidden layer 7 had mean 0.596867 and std 0.870610
hidden layer 8 had mean 0.623214 and std 0.889348
hidden layer 9 had mean 0.567498 and std 0.845357
hidden layer 10 had mean 0.552531 and std 0.844523

He et al., 2015
(note additional /2)

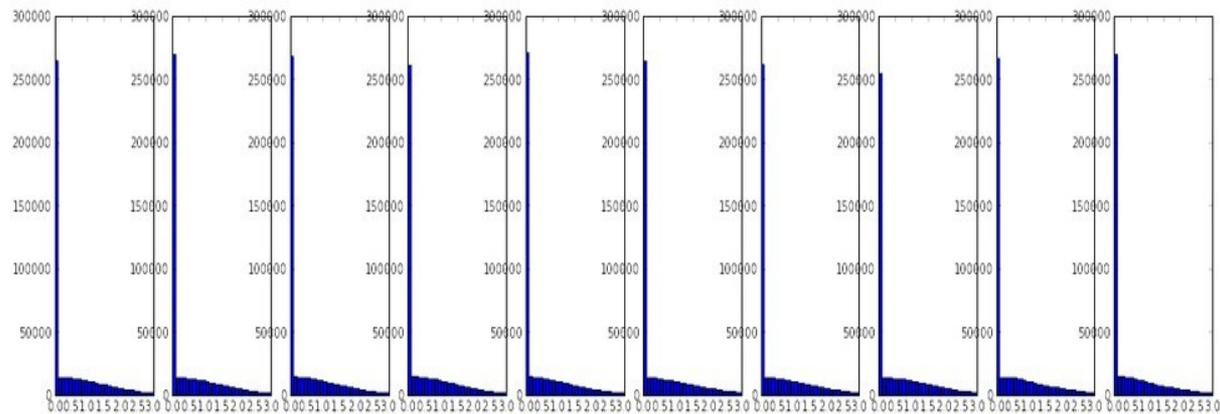
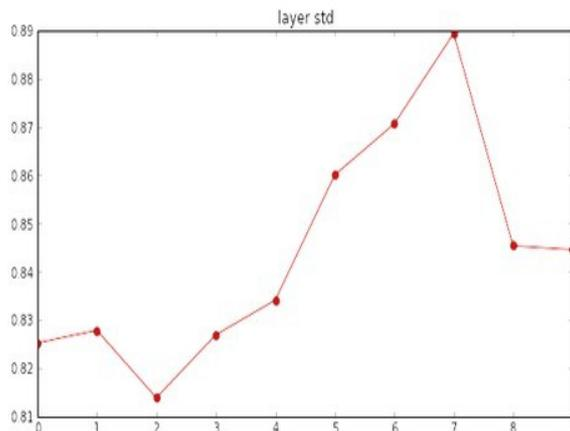
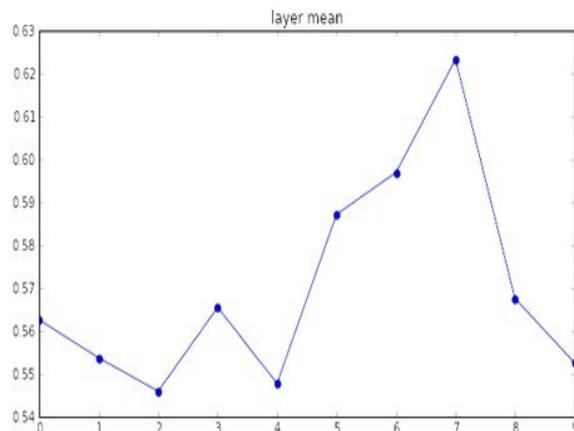

input layer had mean 0.000501 and std 0.999444
 hidden layer 1 had mean 0.562488 and std 0.825232
 hidden layer 2 had mean 0.553614 and std 0.827835
 hidden layer 3 had mean 0.545867 and std 0.813855
 hidden layer 4 had mean 0.565396 and std 0.826902
 hidden layer 5 had mean 0.547678 and std 0.834092
 hidden layer 6 had mean 0.587103 and std 0.860035
 hidden layer 7 had mean 0.596867 and std 0.870610
 hidden layer 8 had mean 0.623214 and std 0.889348
 hidden layer 9 had mean 0.567498 and std 0.845357
 hidden layer 10 had mean 0.552531 and std 0.844523

```
W = np.random.randn(fan_in, fan_out) / np.sqrt(fan_in/2) # layer initialization
```

He et al., 2015 (note additional /2)

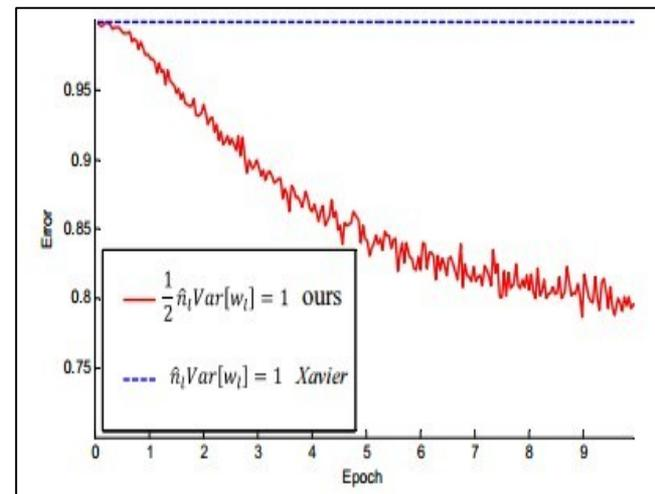
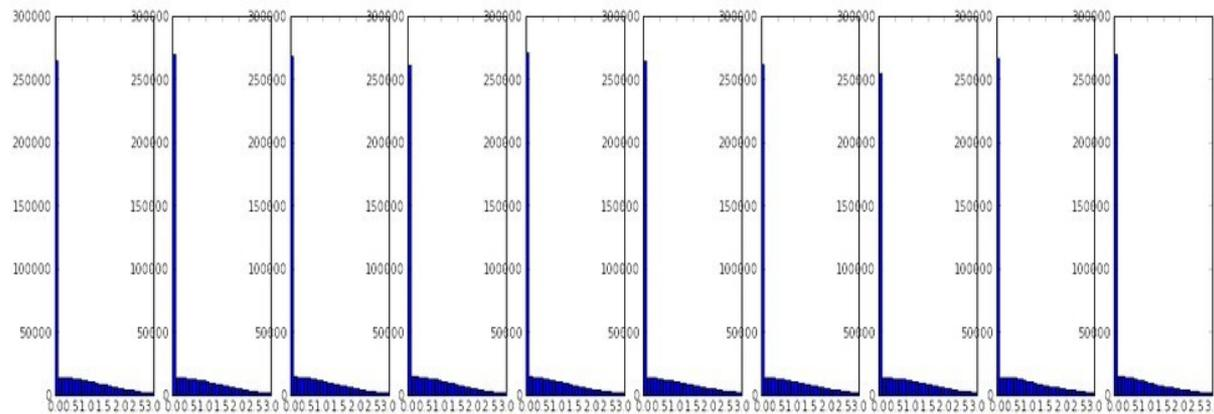
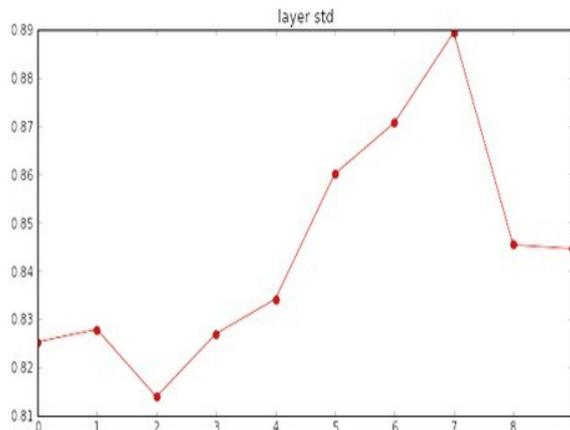
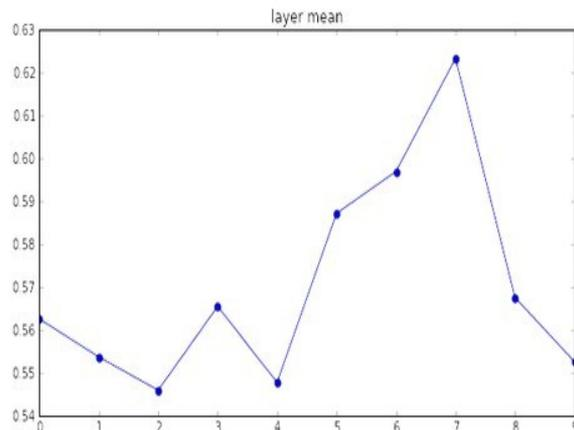

Proper initialization is an active area of research...

Understanding the difficulty of training deep feedforward neural networks

by Glorot and Bengio, 2010

Exact solutions to the nonlinear dynamics of learning in deep linear neural networks by

Saxe et al, 2013

Random walk initialization for training very deep feedforward networks by Sussillo and

Abbott, 2014

Delving deep into rectifiers: Surpassing human-level performance on ImageNet

classification by He et al., 2015

Data-dependent Initializations of Convolutional Neural Networks by Krähenbühl et al., 2015

All you need is a good init, Mishkin and Matas, 2015

...

“you want unit gaussian activations? just make them so.”

consider a batch of activations at some layer.
To make each dimension unit gaussian, apply:

$$\hat{x}^{(k)} = \frac{x^{(k)} - \mathbb{E}[x^{(k)}]}{\sqrt{\text{Var}[x^{(k)}]}}$$

this is a vanilla
differentiable function...

“you want unit gaussian activations?
just make them so.”

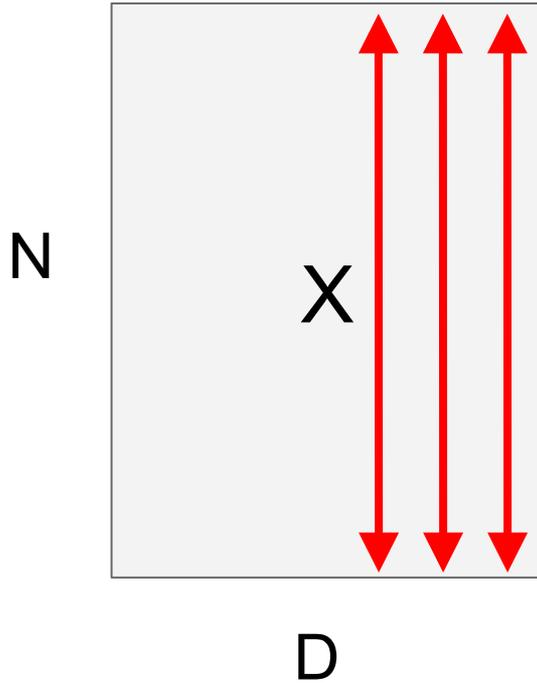

1. compute the empirical mean and variance independently for each dimension.



2. Normalize

$$\hat{x}^{(k)} = \frac{x^{(k)} - \mathbb{E}[x^{(k)}]}{\sqrt{\text{Var}[x^{(k)}]}}$$

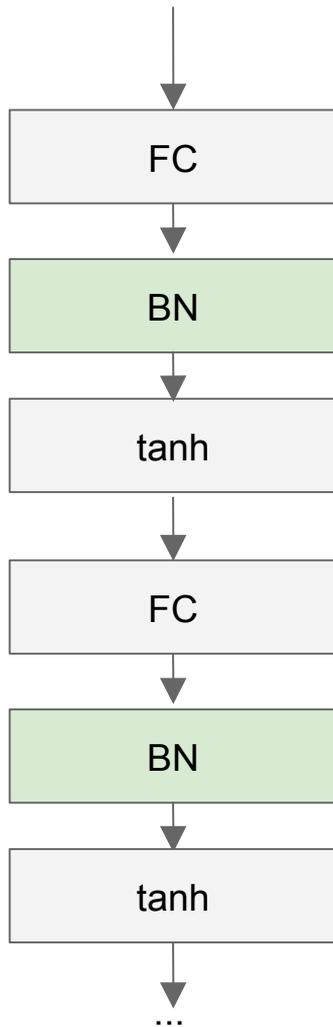

Usually inserted after Fully Connected / (or Convolutional, as we'll see soon) layers, and before nonlinearity.

Problem: do we necessarily want a unit gaussian input to a tanh layer?

$$\hat{x}^{(k)} = \frac{x^{(k)} - \mathbb{E}[x^{(k)}]}{\sqrt{\text{Var}[x^{(k)}]}}$$

Normalize:

$$\hat{x}^{(k)} = \frac{x^{(k)} - \mathbb{E}[x^{(k)}]}{\sqrt{\text{Var}[x^{(k)}]}}$$

And then allow the network to squash the range if it wants to:

$$y^{(k)} = \gamma^{(k)} \hat{x}^{(k)} + \beta^{(k)}$$

Note, the network can learn:

$$\gamma^{(k)} = \sqrt{\text{Var}[x^{(k)}]}$$

$$\beta^{(k)} = \mathbb{E}[x^{(k)}]$$

to recover the identity mapping.

Input: Values of x over a mini-batch: $\mathcal{B} = \{x_{1\dots m}\}$;
Parameters to be learned: γ, β

Output: $\{y_i = \text{BN}_{\gamma, \beta}(x_i)\}$

$$\mu_{\mathcal{B}} \leftarrow \frac{1}{m} \sum_{i=1}^m x_i \quad // \text{ mini-batch mean}$$

$$\sigma_{\mathcal{B}}^2 \leftarrow \frac{1}{m} \sum_{i=1}^m (x_i - \mu_{\mathcal{B}})^2 \quad // \text{ mini-batch variance}$$

$$\hat{x}_i \leftarrow \frac{x_i - \mu_{\mathcal{B}}}{\sqrt{\sigma_{\mathcal{B}}^2 + \epsilon}} \quad // \text{ normalize}$$

$$y_i \leftarrow \gamma \hat{x}_i + \beta \equiv \text{BN}_{\gamma, \beta}(x_i) \quad // \text{ scale and shift}$$

- Improves gradient flow through the network
- Allows higher learning rates
- Reduces the strong dependence on initialization
- Acts as a form of regularization in a funny way, and slightly reduces the need for dropout, maybe

Input: Values of x over a mini-batch: $\mathcal{B} = \{x_{1\dots m}\}$;
Parameters to be learned: γ, β

Output: $\{y_i = \text{BN}_{\gamma, \beta}(x_i)\}$

$$\mu_{\mathcal{B}} \leftarrow \frac{1}{m} \sum_{i=1}^m x_i \quad // \text{ mini-batch mean}$$

$$\sigma_{\mathcal{B}}^2 \leftarrow \frac{1}{m} \sum_{i=1}^m (x_i - \mu_{\mathcal{B}})^2 \quad // \text{ mini-batch variance}$$

$$\hat{x}_i \leftarrow \frac{x_i - \mu_{\mathcal{B}}}{\sqrt{\sigma_{\mathcal{B}}^2 + \epsilon}} \quad // \text{ normalize}$$

$$y_i \leftarrow \gamma \hat{x}_i + \beta \equiv \text{BN}_{\gamma, \beta}(x_i) \quad // \text{ scale and shift}$$

Note: at test time BatchNorm layer functions differently:

The mean/std are not computed based on the batch. Instead, a single fixed empirical mean of activations during training is used.

(e.g. can be estimated during training with running averages)

Fun Tips/Tricks:

1. Train multiple independent models
 2. At test time average their results
- => Enjoy 2% extra performance
- can also get a small boost from averaging multiple model checkpoints of a single model.
 - keep track of (and use at test time) a running average parameter vector:

```
while True:
    data_batch = dataset.sample_data_batch()
    loss = network.forward(data_batch)
    dx = network.backward()
    x += - learning_rate * dx
    x_test = 0.995*x_test + 0.005*x # use for test set
```

Regularization: Dropout

“randomly set some neurons to zero in the forward pass”

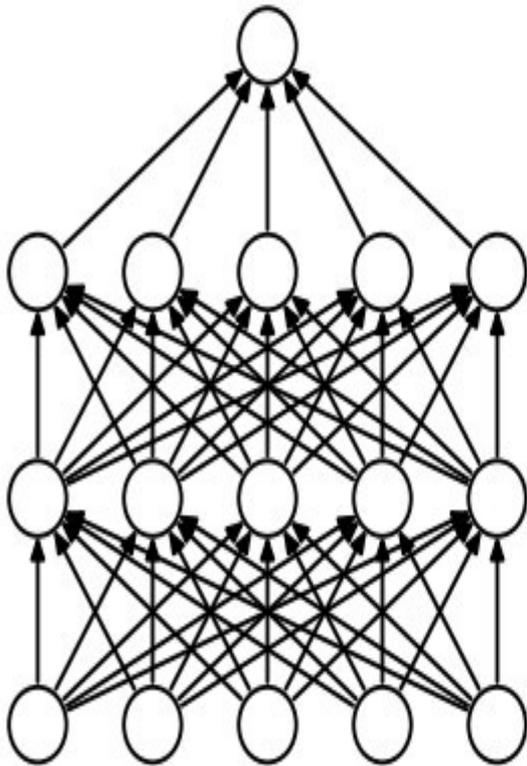

(a) Standard Neural Net

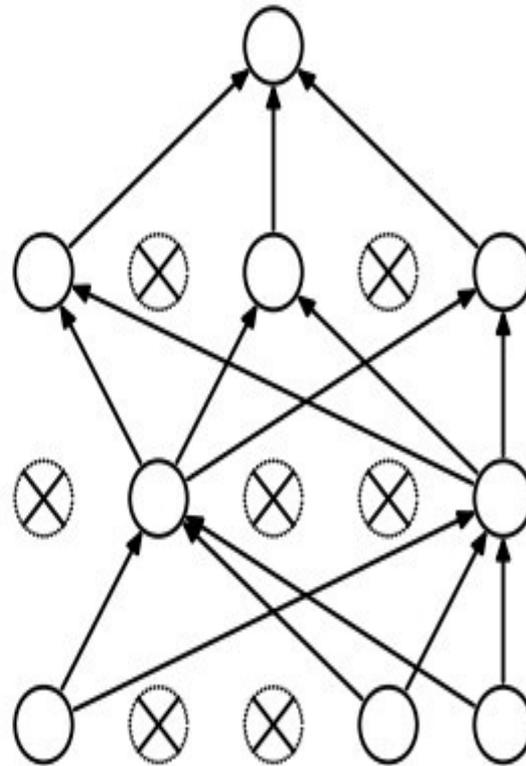

(b) After applying dropout.

[Srivastava et al., 2014]

Regularization: **DisturbLabel**

“randomly change ground truth label of small % of examples”

=>Improves generalization, reduces need for dropout

Case Study: GoogLeNet

[Szegedy et al., 2014]

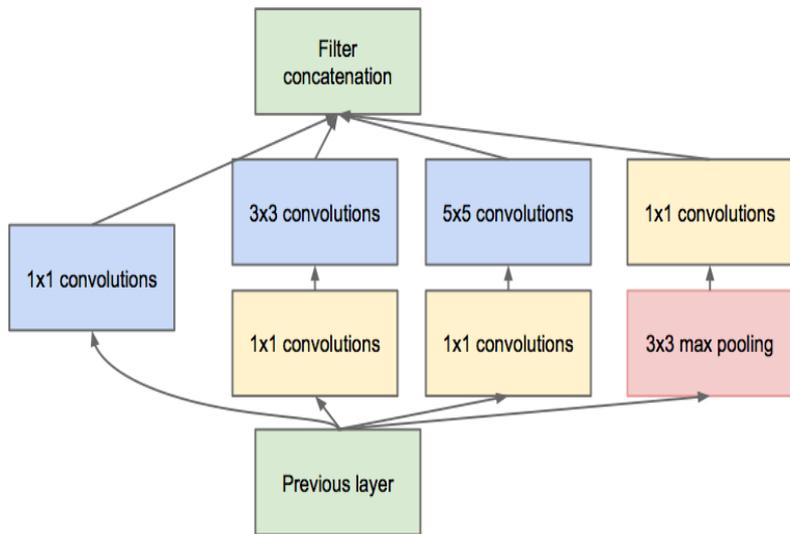
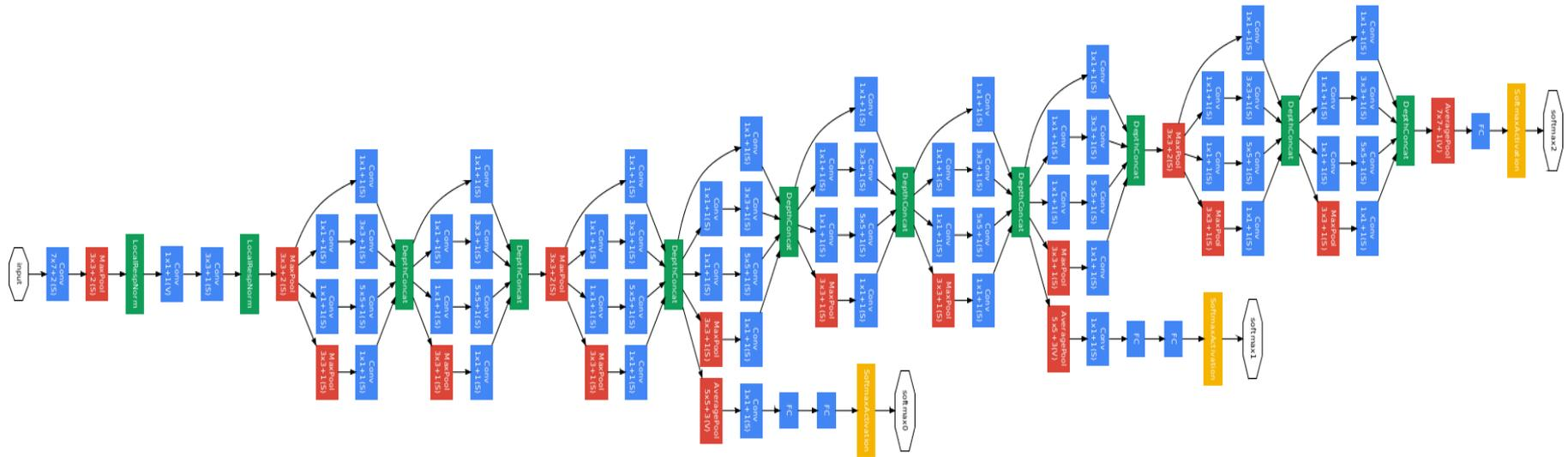

Inception module

ILSVRC 2014 winner (6.7% top 5 error)

Case Study: GoogLeNet

type	patch size/ stride	output size	depth	#1×1	#3×3 reduce	#3×3	#5×5 reduce	#5×5	pool proj	params	ops
convolution	7×7/2	112×112×64	1							2.7K	34M
max pool	3×3/2	56×56×64	0								
convolution	3×3/1	56×56×192	2		64	192				112K	360M
max pool	3×3/2	28×28×192	0								
inception (3a)		28×28×256	2	64	96	128	16	32	32	159K	128M
inception (3b)		28×28×480	2	128	128	192	32	96	64	380K	304M
max pool	3×3/2	14×14×480	0								
inception (4a)		14×14×512	2	192	96	208	16	48	64	364K	73M
inception (4b)		14×14×512	2	160	112	224	24	64	64	437K	88M
inception (4c)		14×14×512	2	128	128	256	24	64	64	463K	100M
inception (4d)		14×14×528	2	112	144	288	32	64	64	580K	119M
inception (4e)		14×14×832	2	256	160	320	32	128	128	840K	170M
max pool	3×3/2	7×7×832	0								
inception (5a)		7×7×832	2	256	160	320	32	128	128	1072K	54M
inception (5b)		7×7×1024	2	384	192	384	48	128	128	1388K	71M
avg pool	7×7/1	1×1×1024	0								
dropout (40%)		1×1×1024	0								
linear		1×1×1000	1							1000K	1M
softmax		1×1×1000	0								

Fun features:

- Only 5 million params!
(Removes FC layers completely)

Compared to AlexNet:

- 12X less params
- 2x more compute
- 6.67% (vs. 16.4%)

Case Study: ResNet [He et al., 2015]

ILSVRC 2015 winner (3.6% top 5 error)

Microsoft
Research

MSRA @ ILSVRC & COCO 2015 Competitions

- **1st places in all five main tracks**
 - ImageNet Classification: “Ultra-deep” (quote Yann) **152-layer** nets
 - ImageNet Detection: **16%** better than 2nd
 - ImageNet Localization: **27%** better than 2nd
 - COCO Detection: **11%** better than 2nd
 - COCO Segmentation: **12%** better than 2nd

*improvements are relative numbers

ICCV15
International Conference on Computer Vision

Kaiming He, Xiangyu Zhang, Shaoqing Ren, & Jian Sun. “Deep Residual Learning for Image Recognition”. arXiv 2015.

Slide from Kaiming He’s recent presentation <https://www.youtube.com/watch?v=1PGLj-uKT1w>

Revolution of Depth

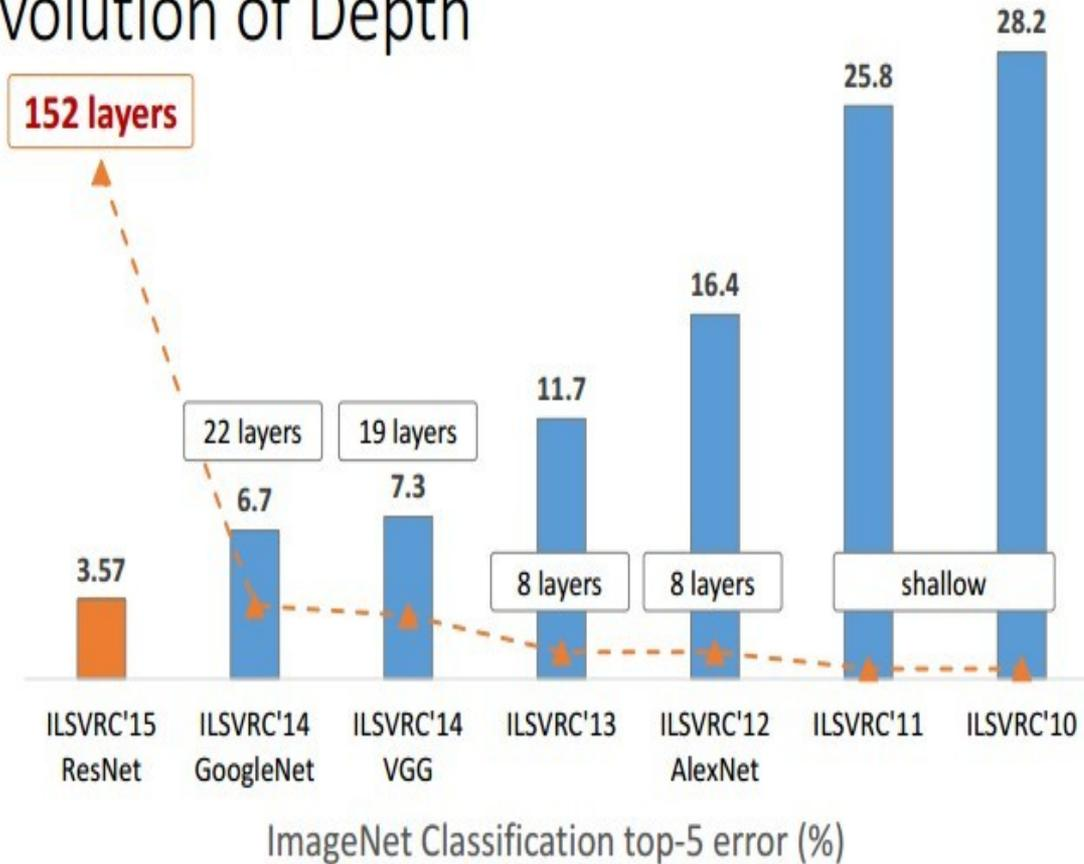

Kaiming He, Xiangyu Zhang, Shaoqing Ren, & Jian Sun. "Deep Residual Learning for Image Recognition". arXiv 2015.

(slide from Kaiming He's recent presentation)

CIFAR-10 experiments

CIFAR-10 plain nets

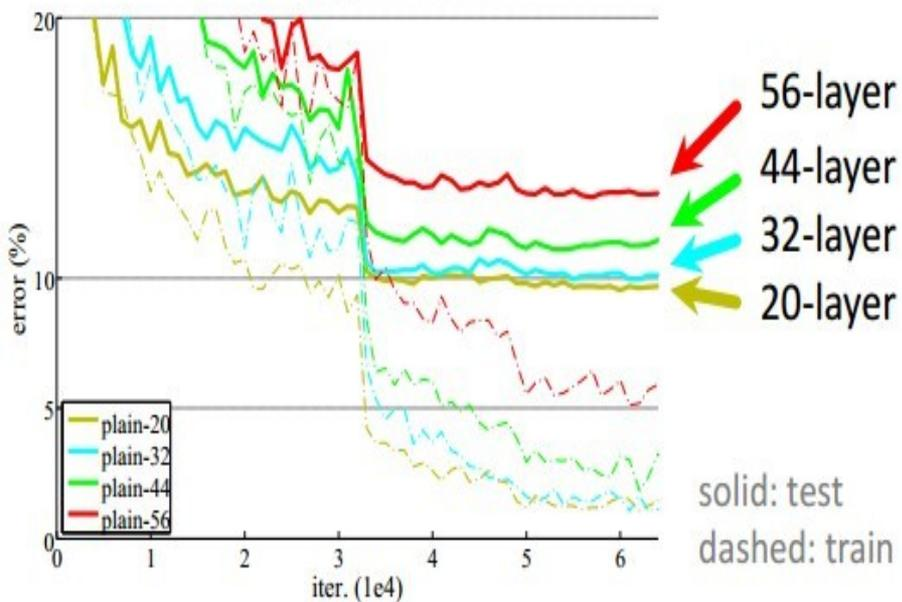

CIFAR-10 ResNets

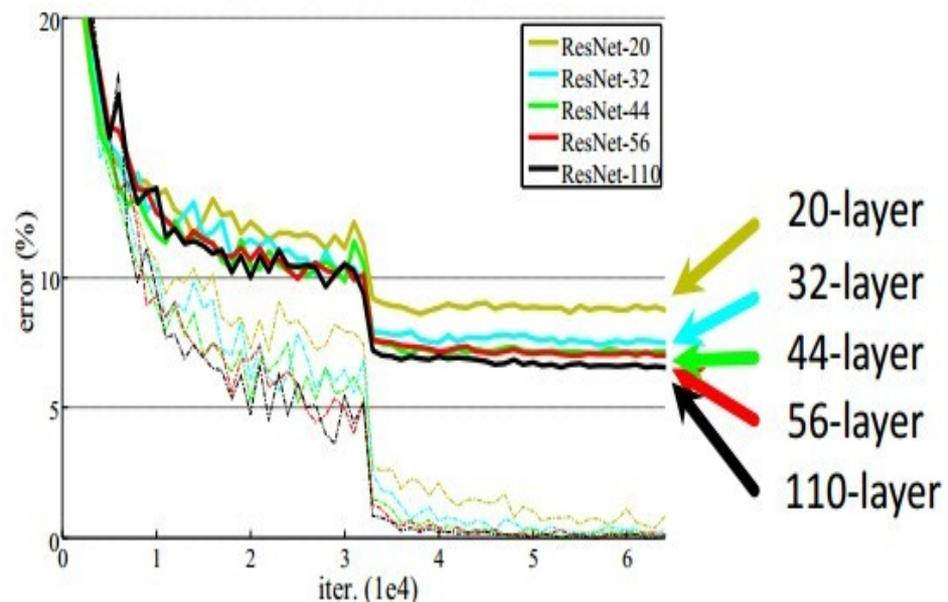

Case Study: ResNet [He et al., 2015]

ILSVRC 2015 winner (3.6% top 5 error)

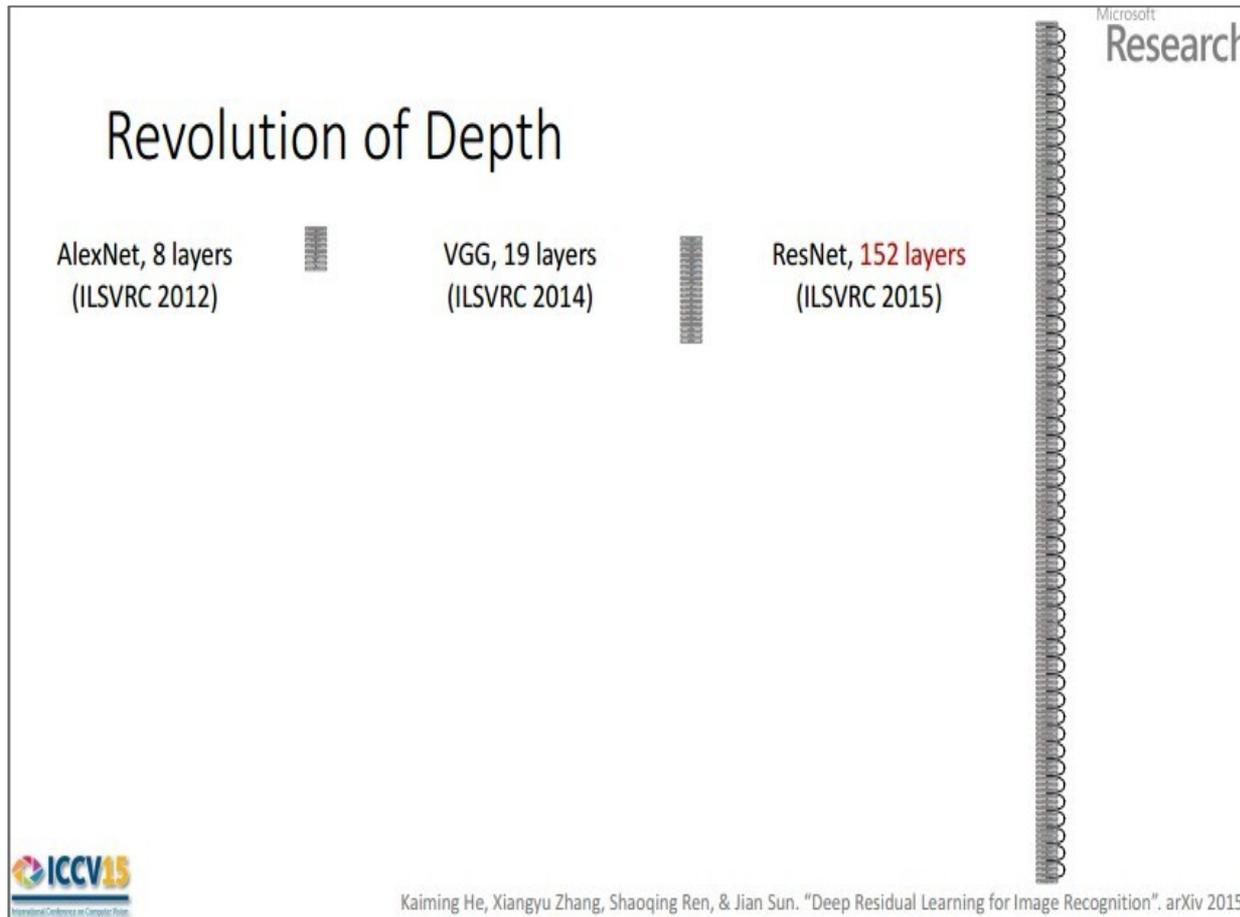

2-3 weeks of training on 8 GPU machine

at runtime: faster than a VGGNet! (even though it has 8x more layers)

(slide from Kaiming He's recent presentation)

Case Study: ResNet

[He et al., 2015]

34-layer plain

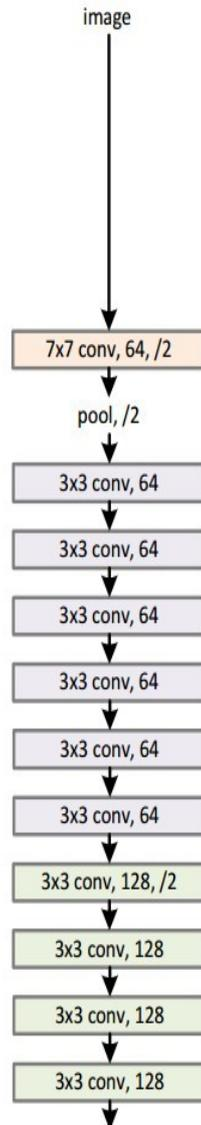

34-layer residual

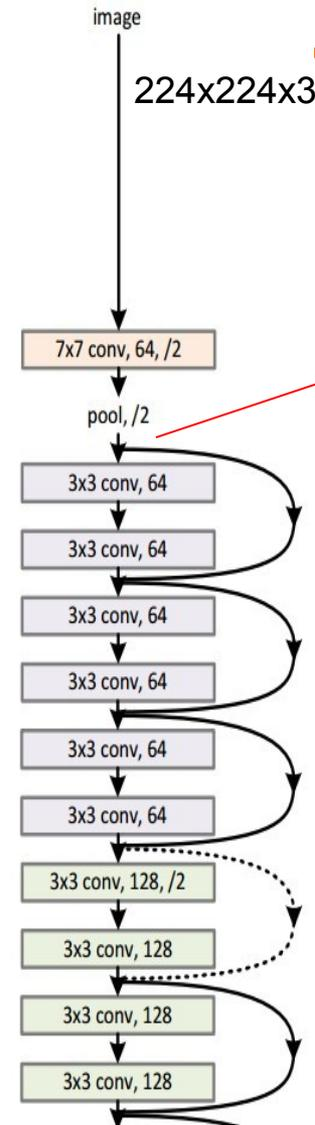

spatial dimension
only 56x56!

Case Study: ResNet

[He et al., 2015]

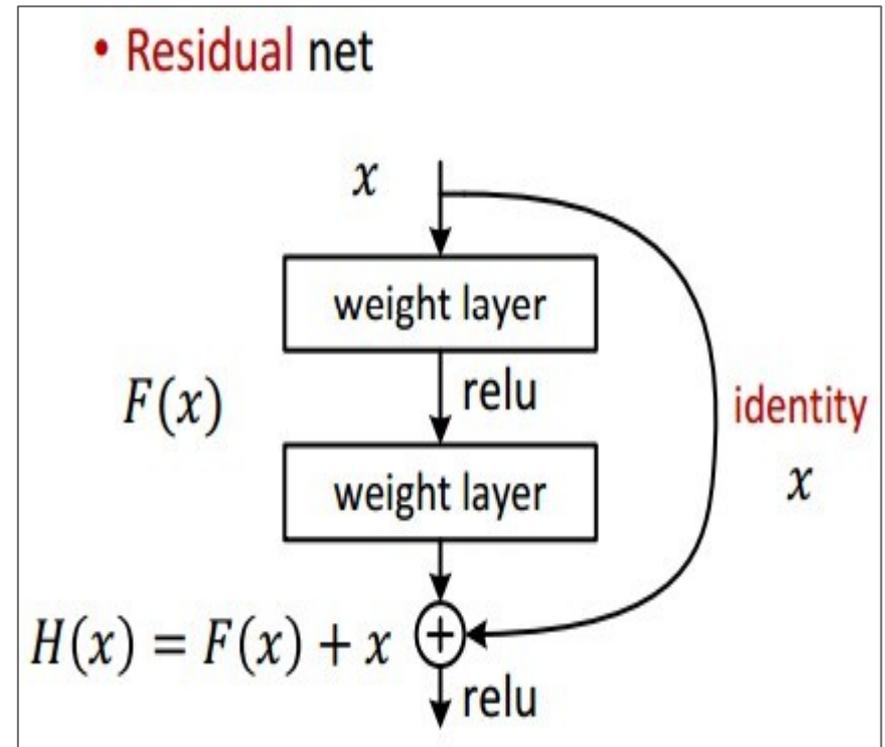
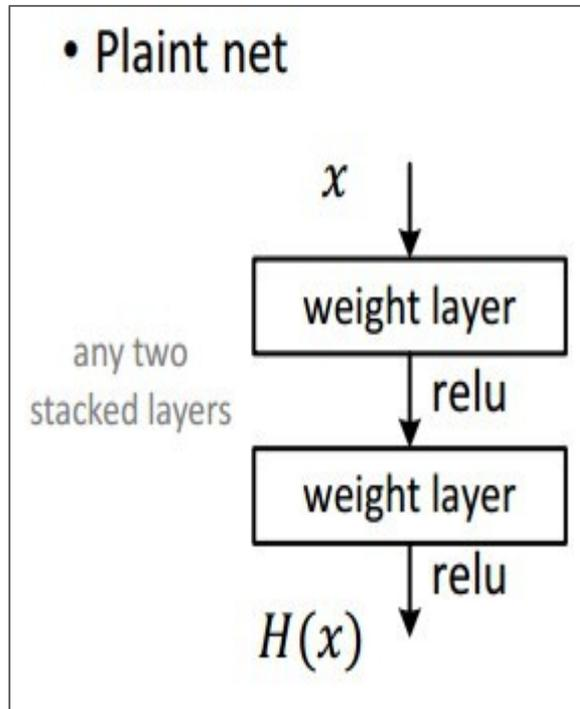

Case Study: ResNet

[He et al., 2015]

- Batch Normalization after every CONV layer
- Xavier/2 initialization from He et al.
- SGD + Momentum (0.9)
- Learning rate: 0.1, divided by 10 when validation error plateaus
- Mini-batch size 256
- Weight decay of $1e-5$
- No dropout used

Case Study: ResNet

[He et al., 2015]

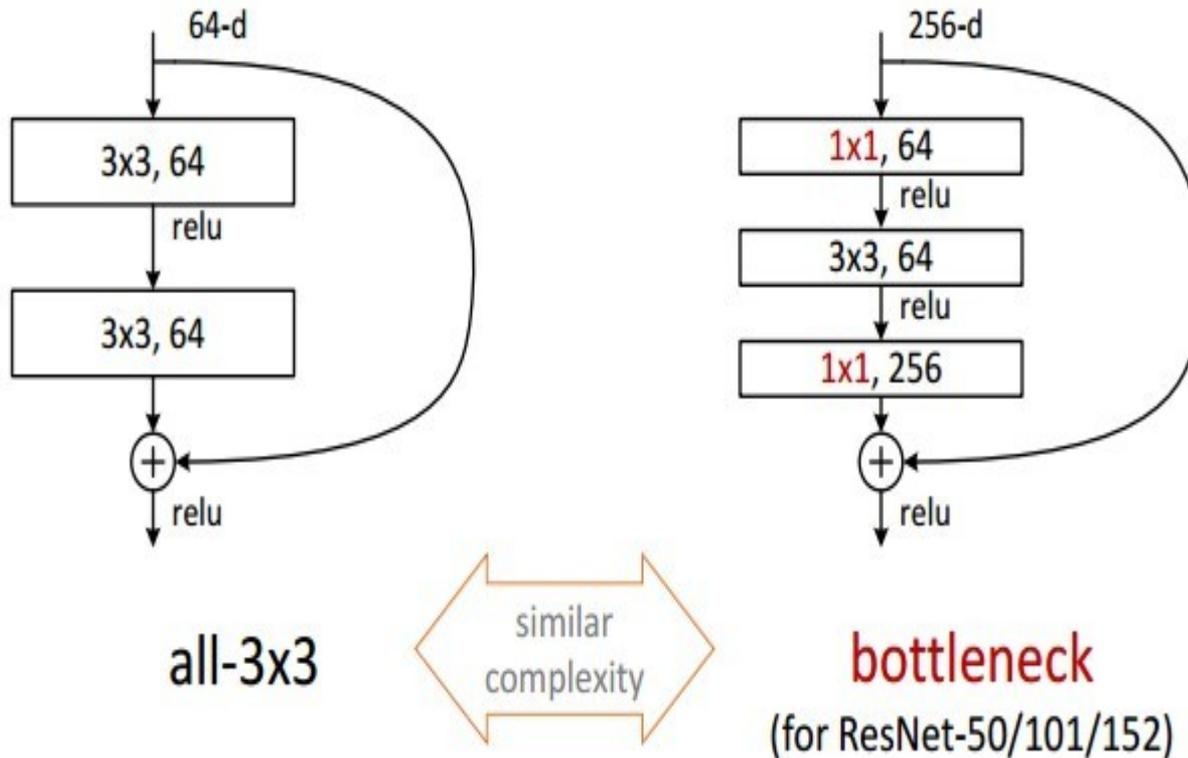

Case Study: ResNet

[He et al., 2015]

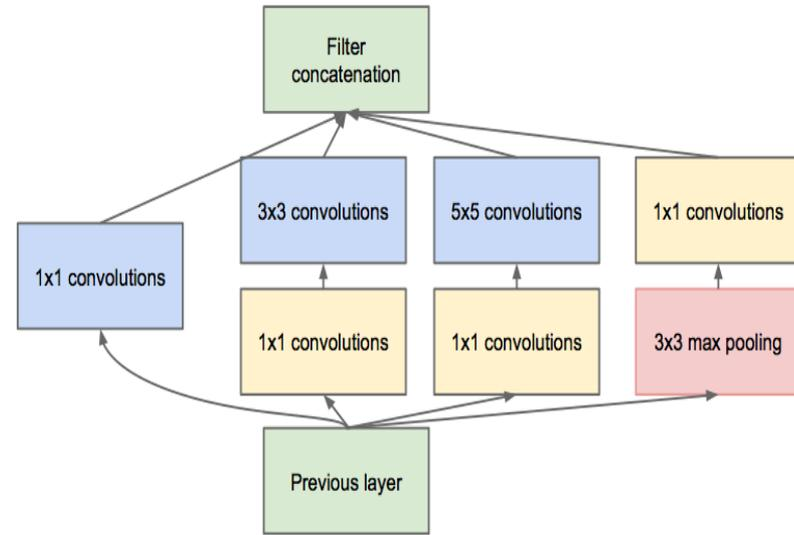
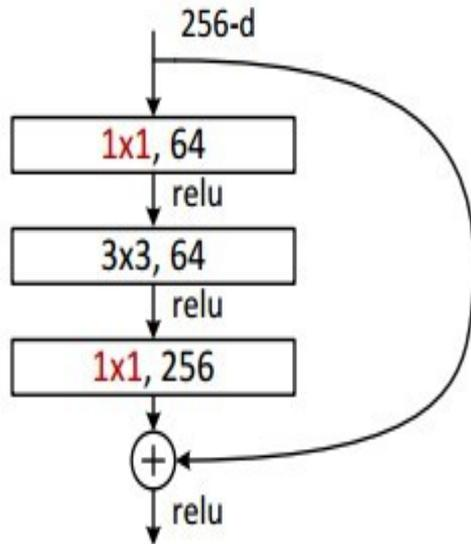

(this trick is also used in GoogLeNet)

Case Study: ResNet [He et al., 2015]

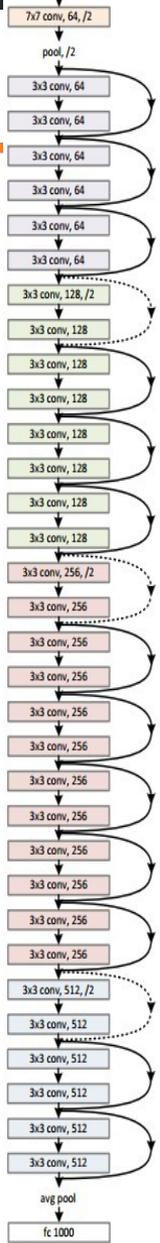

layer name	output size	18-layer	34-layer	50-layer	101-layer	152-layer
conv1	112×112	7×7, 64, stride 2				
conv2_x	56×56	3×3 max pool, stride 2				
		$\begin{bmatrix} 3 \times 3, 64 \\ 3 \times 3, 64 \end{bmatrix} \times 2$	$\begin{bmatrix} 3 \times 3, 64 \\ 3 \times 3, 64 \end{bmatrix} \times 3$	$\begin{bmatrix} 1 \times 1, 64 \\ 3 \times 3, 64 \\ 1 \times 1, 256 \end{bmatrix} \times 3$	$\begin{bmatrix} 1 \times 1, 64 \\ 3 \times 3, 64 \\ 1 \times 1, 256 \end{bmatrix} \times 3$	$\begin{bmatrix} 1 \times 1, 64 \\ 3 \times 3, 64 \\ 1 \times 1, 256 \end{bmatrix} \times 3$
conv3_x	28×28	$\begin{bmatrix} 3 \times 3, 128 \\ 3 \times 3, 128 \end{bmatrix} \times 2$	$\begin{bmatrix} 3 \times 3, 128 \\ 3 \times 3, 128 \end{bmatrix} \times 4$	$\begin{bmatrix} 1 \times 1, 128 \\ 3 \times 3, 128 \\ 1 \times 1, 512 \end{bmatrix} \times 4$	$\begin{bmatrix} 1 \times 1, 128 \\ 3 \times 3, 128 \\ 1 \times 1, 512 \end{bmatrix} \times 4$	$\begin{bmatrix} 1 \times 1, 128 \\ 3 \times 3, 128 \\ 1 \times 1, 512 \end{bmatrix} \times 8$
conv4_x	14×14	$\begin{bmatrix} 3 \times 3, 256 \\ 3 \times 3, 256 \end{bmatrix} \times 2$	$\begin{bmatrix} 3 \times 3, 256 \\ 3 \times 3, 256 \end{bmatrix} \times 6$	$\begin{bmatrix} 1 \times 1, 256 \\ 3 \times 3, 256 \\ 1 \times 1, 1024 \end{bmatrix} \times 6$	$\begin{bmatrix} 1 \times 1, 256 \\ 3 \times 3, 256 \\ 1 \times 1, 1024 \end{bmatrix} \times 23$	$\begin{bmatrix} 1 \times 1, 256 \\ 3 \times 3, 256 \\ 1 \times 1, 1024 \end{bmatrix} \times 36$
conv5_x	7×7	$\begin{bmatrix} 3 \times 3, 512 \\ 3 \times 3, 512 \end{bmatrix} \times 2$	$\begin{bmatrix} 3 \times 3, 512 \\ 3 \times 3, 512 \end{bmatrix} \times 3$	$\begin{bmatrix} 1 \times 1, 512 \\ 3 \times 3, 512 \\ 1 \times 1, 2048 \end{bmatrix} \times 3$	$\begin{bmatrix} 1 \times 1, 512 \\ 3 \times 3, 512 \\ 1 \times 1, 2048 \end{bmatrix} \times 3$	$\begin{bmatrix} 1 \times 1, 512 \\ 3 \times 3, 512 \\ 1 \times 1, 2048 \end{bmatrix} \times 3$
	1×1	average pool, 1000-d fc, softmax				
FLOPs		1.8×10^9	3.6×10^9	3.8×10^9	7.6×10^9	11.3×10^9

Case Study Bonus: DeepMind's AlphaGo

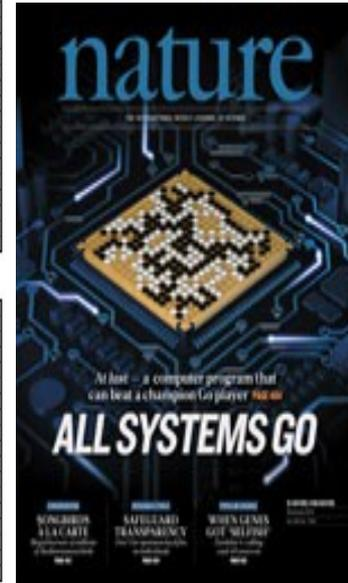
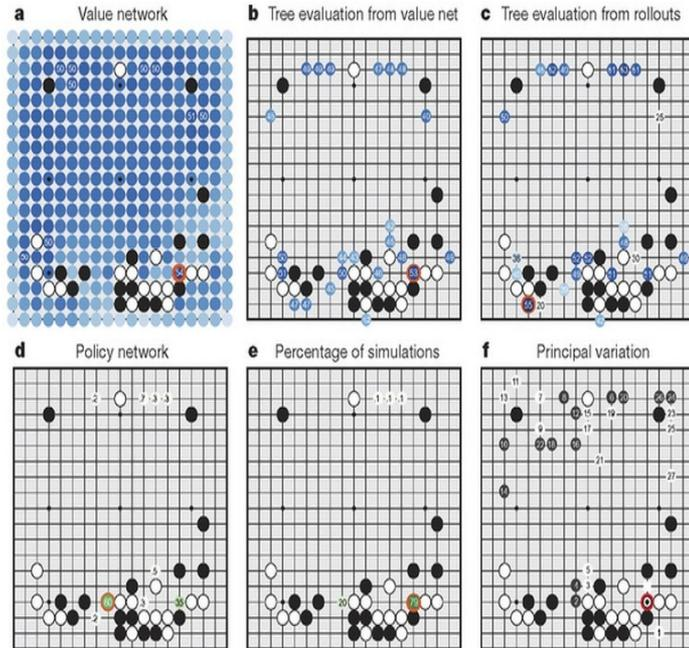

The input to the policy network is a $19 \times 19 \times 48$ image stack consisting of 48 feature planes. The first hidden layer zero pads the input into a 23×23 image, then convolves k filters of kernel size 5×5 with stride 1 with the input image and applies a rectifier nonlinearity. Each of the subsequent hidden layers 2 to 12 zero pads the respective previous hidden layer into a 21×21 image, then convolves k filters of kernel size 3×3 with stride 1, again followed by a rectifier nonlinearity. The final layer convolves 1 filter of kernel size 1×1 with stride 1, with a different bias for each position, and applies a softmax function. The match version of AlphaGo used $k = 192$ filters; [Fig. 2b](#) and [Extended Data Table 3](#) additionally show the results of training with $k = 128, 256$ and 384 filters.

policy network:

[19x19x48] Input

CONV1: 192 5x5 filters , stride 1, pad 2 => [19x19x192]

CONV2..12: 192 3x3 filters, stride 1, pad 1 => [19x19x192]

CONV: 1 1x1 filter, stride 1, pad 0 => [19x19] (*probability map of promising moves*)

Computer Vision Tasks

Classification



CAT

**Classification
+ Localization**



CAT

Object Detection

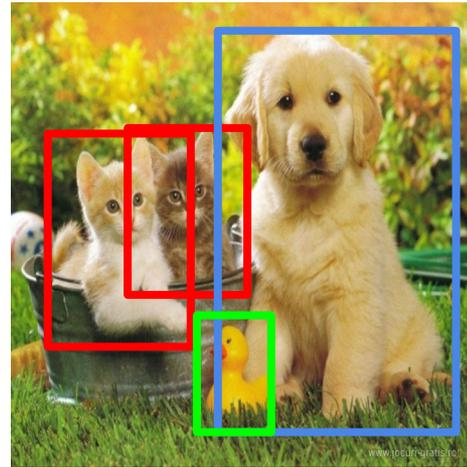

CAT, DOG, DUCK

**Instance
Segmentation**



CAT, DOG, DUCK

Single object

Multiple objects

Computer Vision Tasks

Classification

**Classification
+ Localization**

Object Detection

Instance
Segmentation

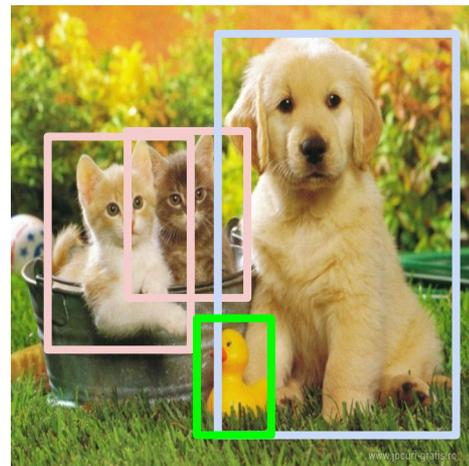

Classification + Localization: Task

Classification: C classes

Input: Image

Output: Class label

Evaluation metric: Accuracy



→ CAT

Localization:

Input: Image

Output: Box in the image (x, y, w, h)

Evaluation metric: Intersection over Union



→ (x, y, w, h)

Classification + Localization: Do both

Classification + Localization: ImageNet

1000 classes (same as classification)

Each image has 1 class, at least one bounding box

~800 training images per class

Algorithm produces 5 (class, box) guesses

Example is correct if at least one one guess has correct class AND bounding box at least 0.5 intersection over union (IoU)

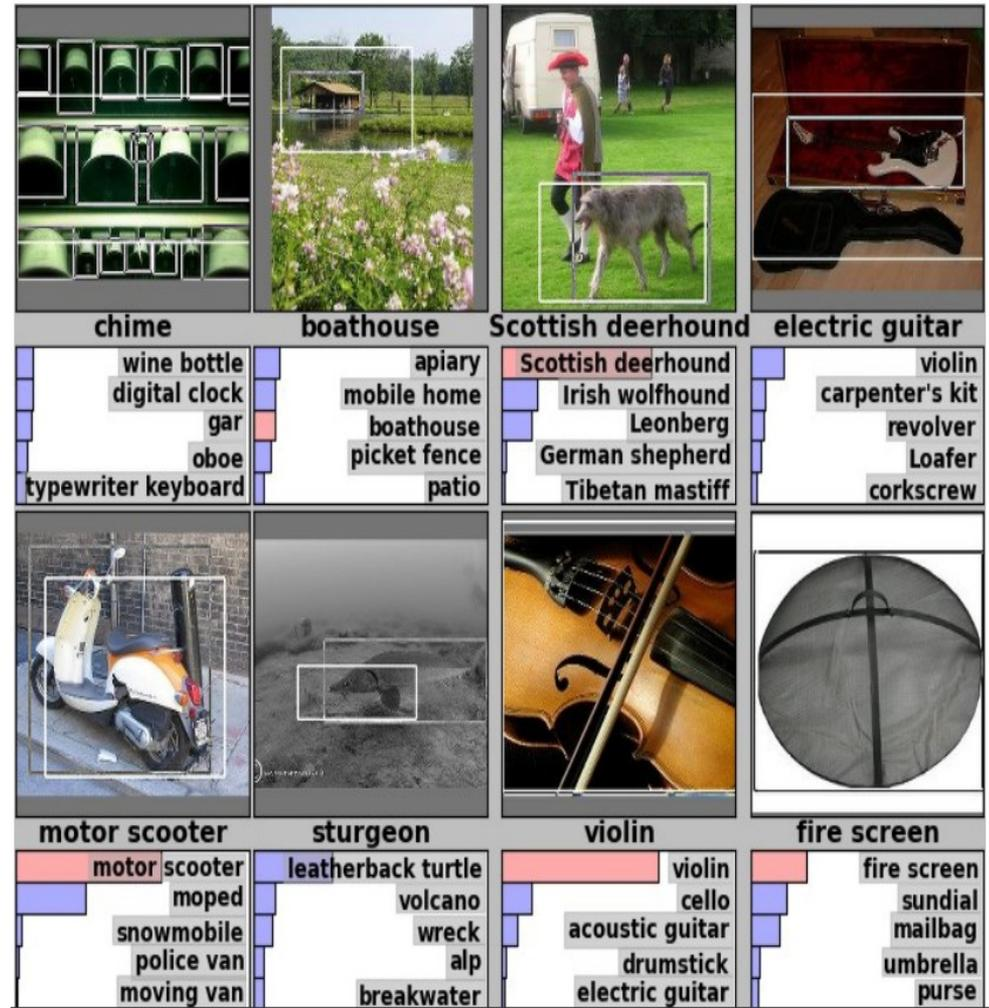

Krizhevsky et. al. 2012

Idea #1: Localization as Regression

Input: image



Neural Net
→

Output:
Box coordinates
(4 numbers)

Correct output:
box coordinates
(4 numbers)

Loss:
L2 distance

Only one object,
simpler than detection

Simple Recipe for Classification + Localization

Step 1: Train (or download) a classification model (AlexNet, VGG, GoogLeNet)

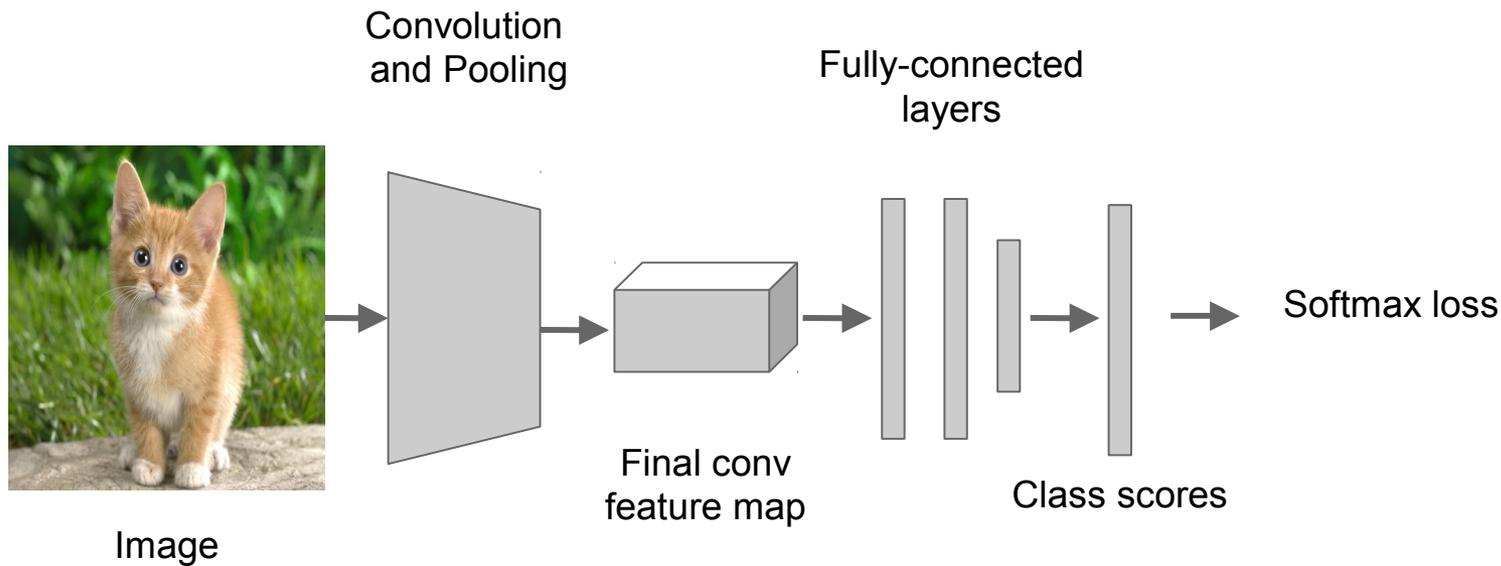

Simple Recipe for Classification + Localization

Step 2: Attach new fully-connected “regression head” to the network

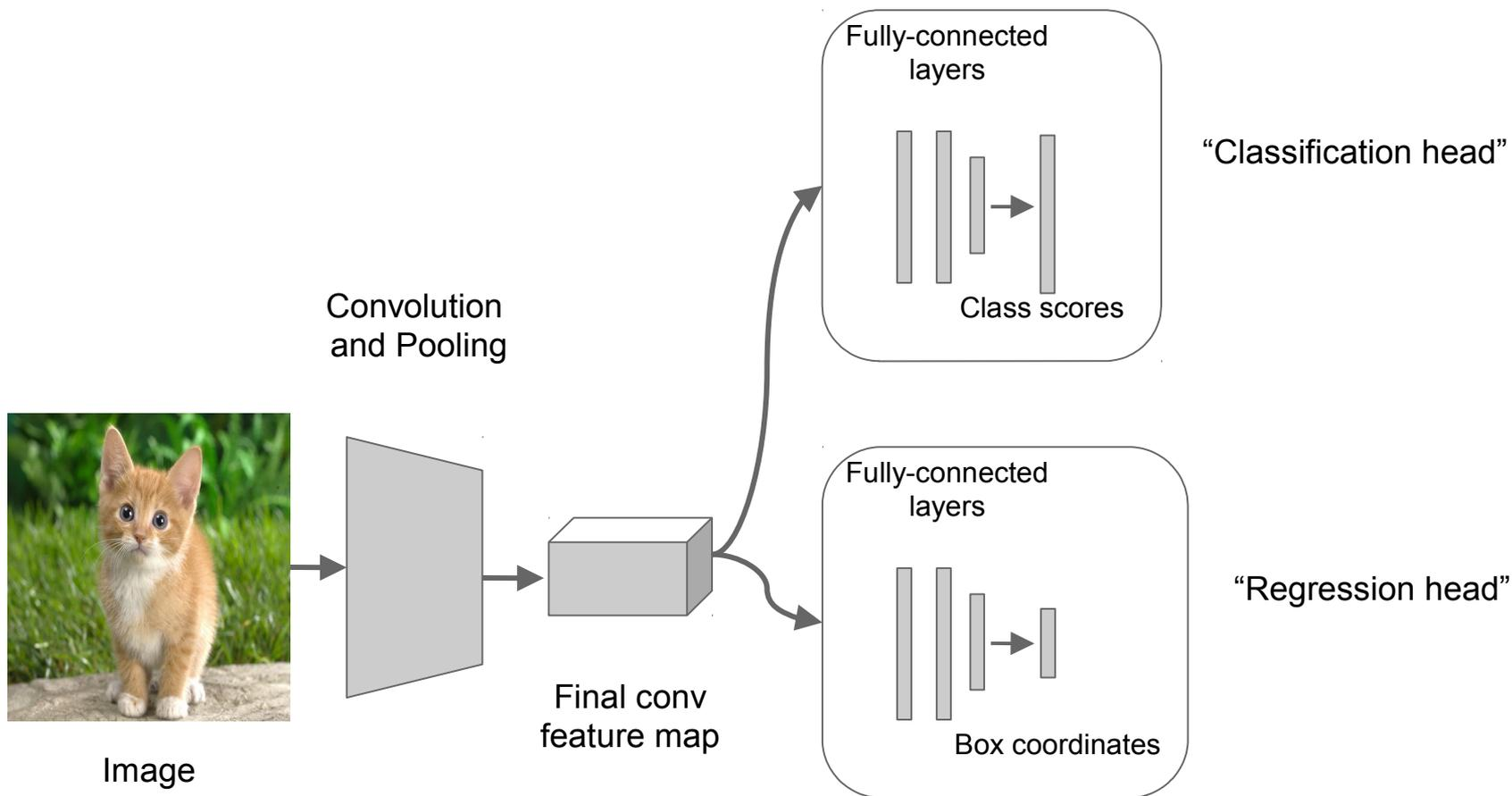

Simple Recipe for Classification + Localization

Step 3: Train the regression head only with SGD and L2 loss

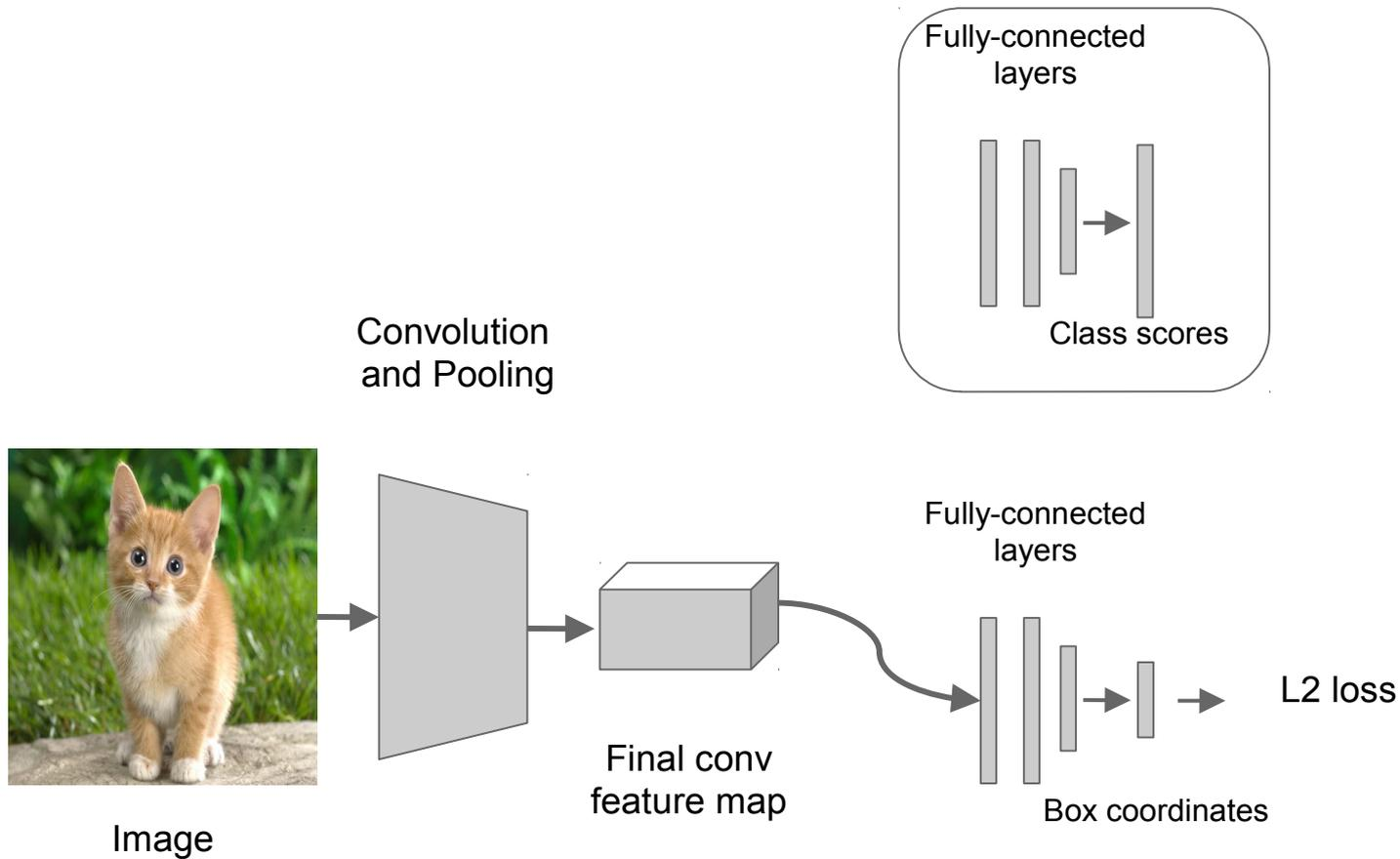

Simple Recipe for Classification + Localization

Step 4: At test time use both heads

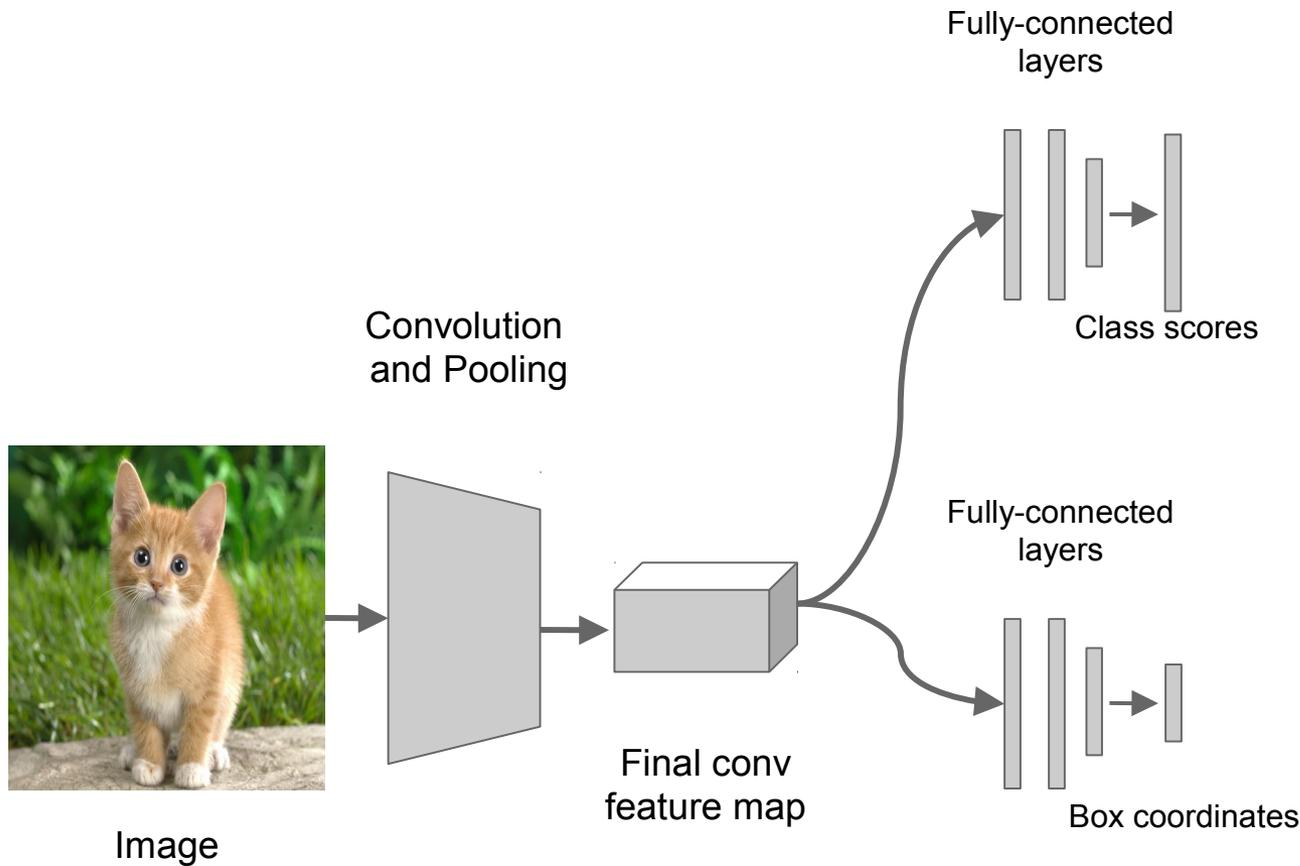

Per-class vs class agnostic regression

Assume classification
over C classes:

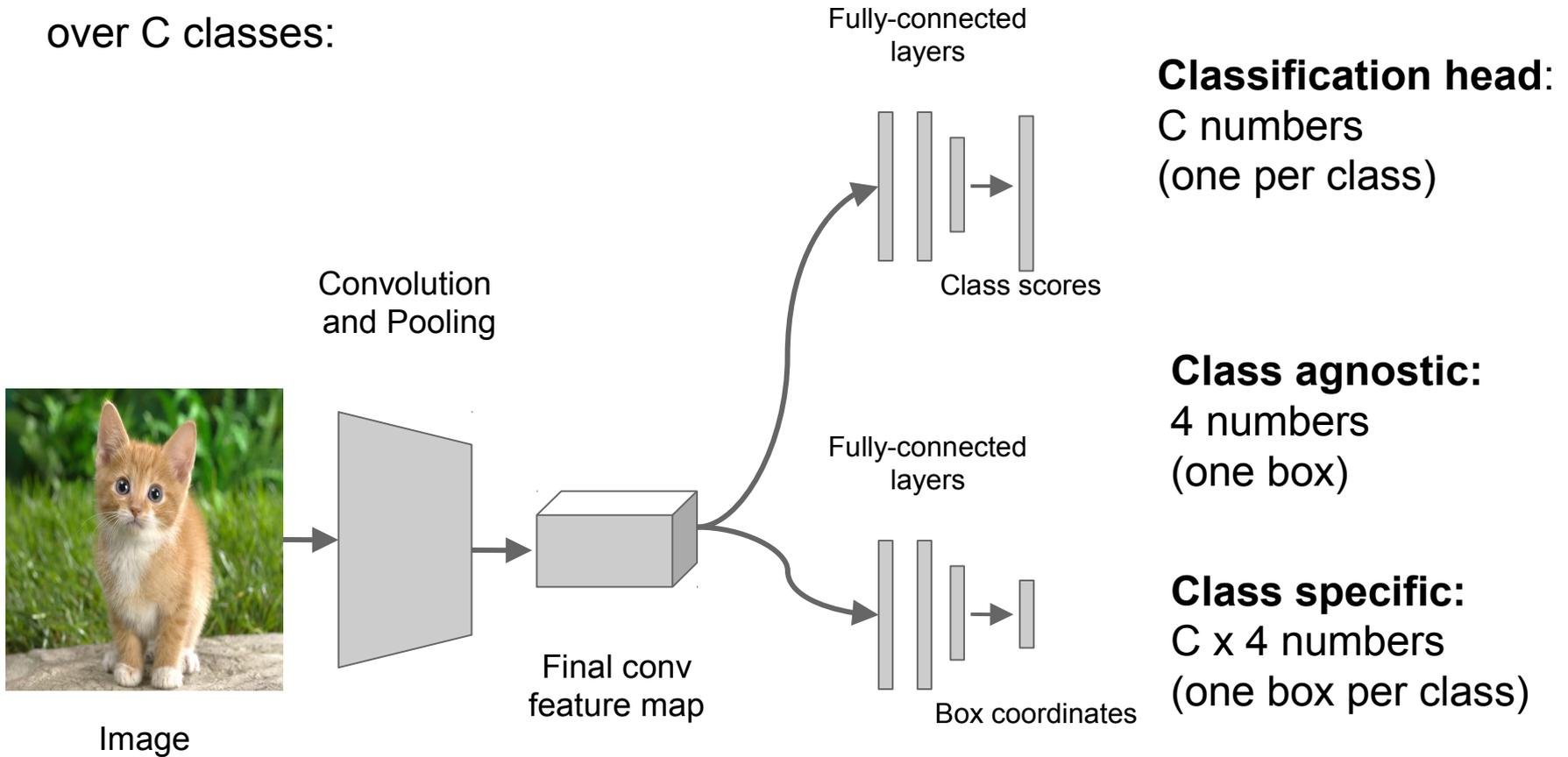

Where to attach the regression head?

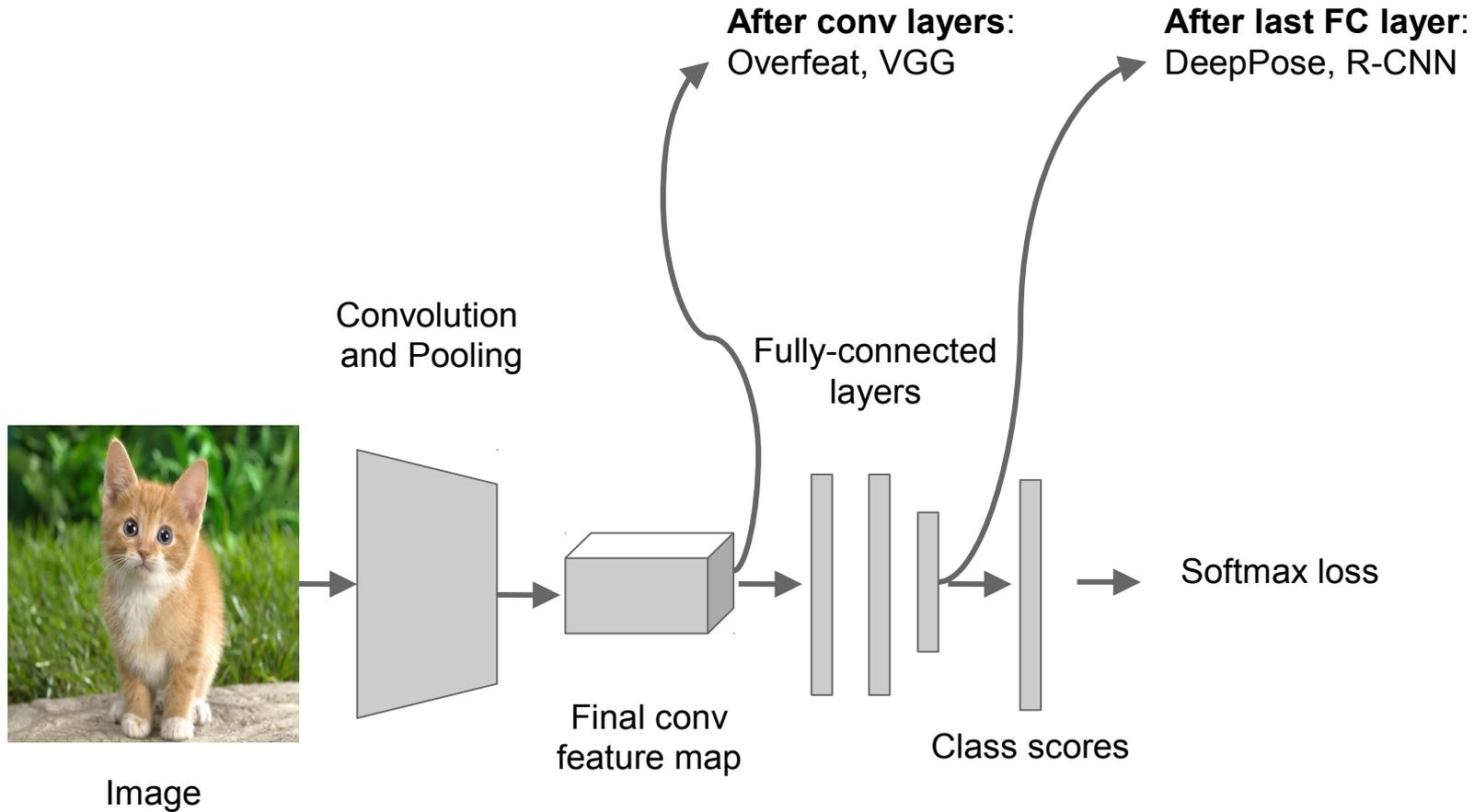

Aside: Localizing multiple objects

Want to localize **exactly** K objects in each image

(e.g. whole cat, cat head, cat left ear, cat right ear for $K=4$)

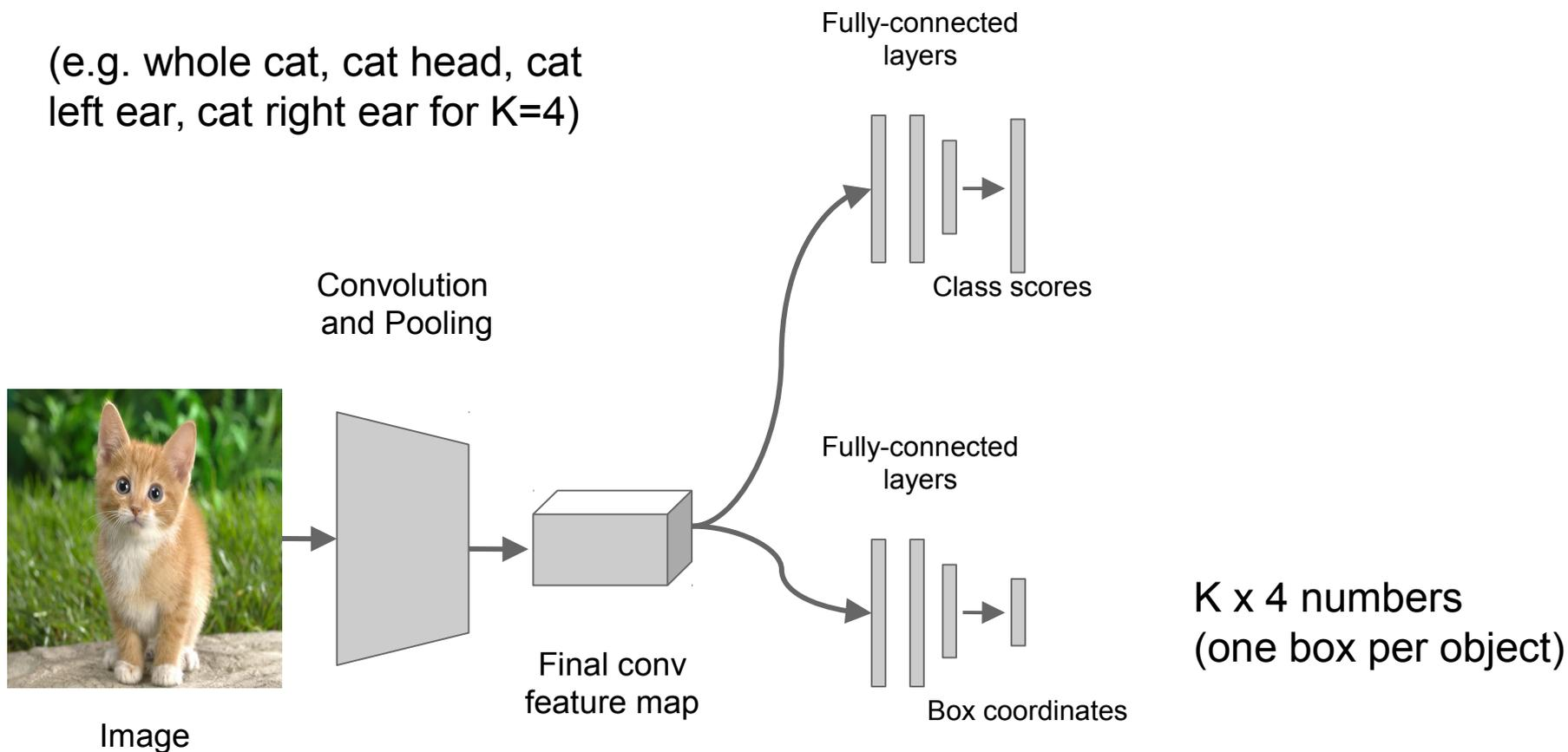

Aside: Human Pose Estimation

Represent a person by K joints

Regress (x, y) for each joint from last fully-connected layer of AlexNet

(Details: Normalized coordinates, iterative refinement)

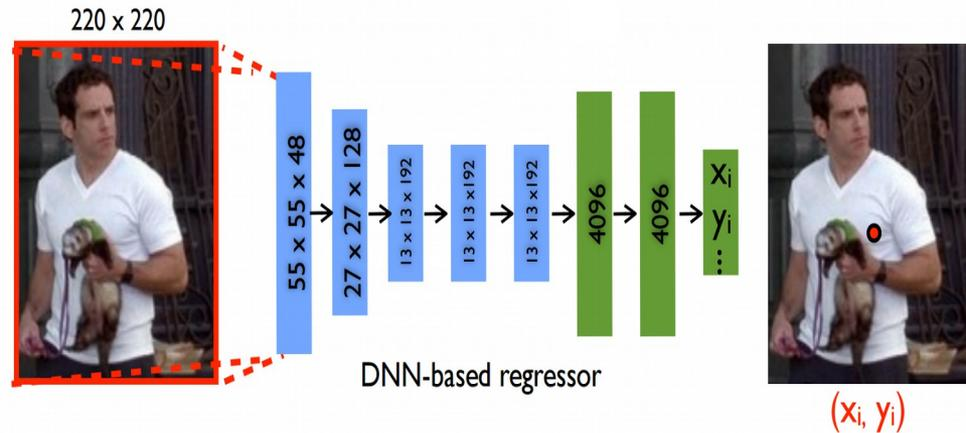

Toshev and Szegedy, "DeepPose: Human Pose Estimation via Deep Neural Networks", CVPR 2014

Localization as Regression

Very simple

Think if you can use this for projects

Idea #2: Sliding Window

- Run classification + regression network at multiple locations on a high-resolution image
- Convert fully-connected layers into convolutional layers for efficient computation
- Combine classifier and regressor predictions across all scales for final prediction

Sliding Window: Overfeat

Winner of ILSVRC 2013
localization challenge

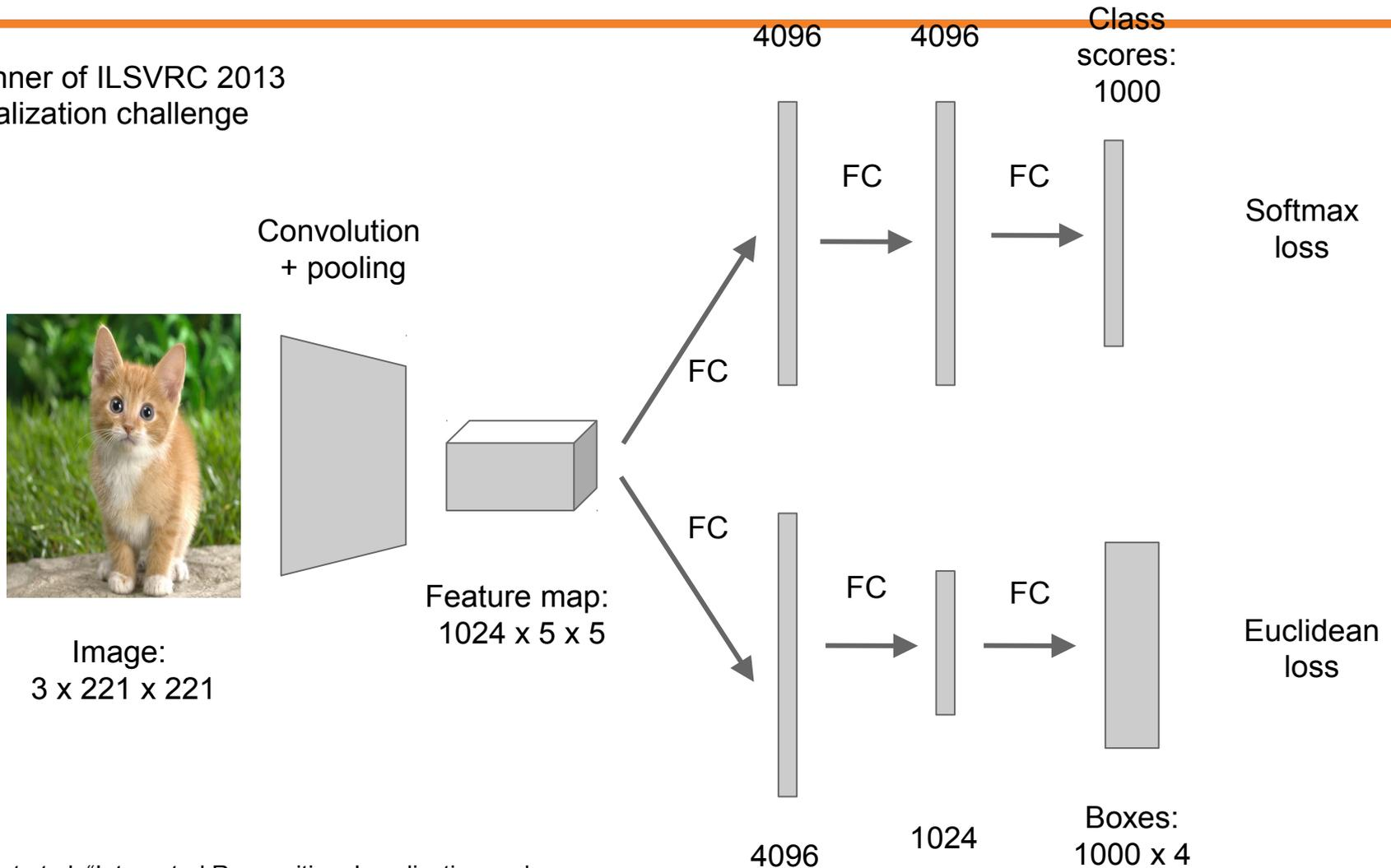

Sermanet et al, "Integrated Recognition, Localization and Detection using Convolutional Networks", ICLR 2014

Sliding Window: Overfeat

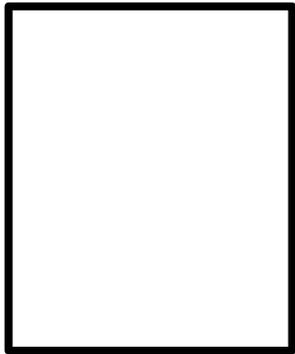

Network input:
3 x 221 x 221



Larger image:
3 x 257 x 257

Sliding Window: Overfeat

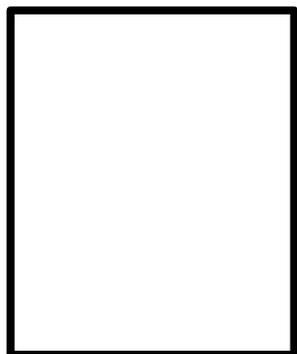

Network input:
 $3 \times 221 \times 221$

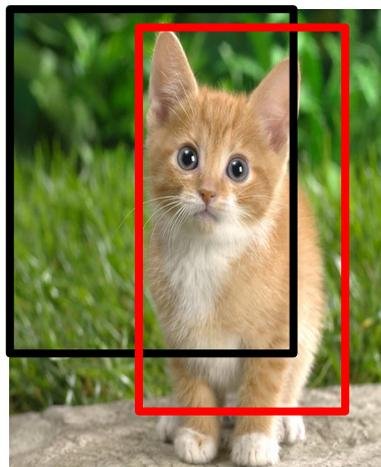

Larger image:
 $3 \times 257 \times 257$

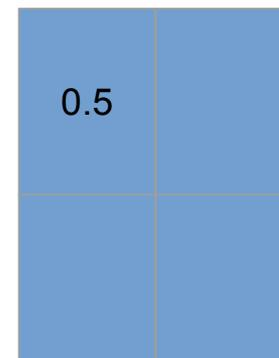

Classification scores:
 $P(\text{cat})$

Sliding Window: Overfeat

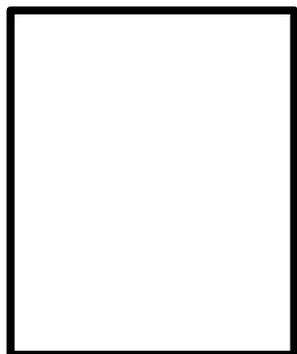

Network input:
 $3 \times 221 \times 221$

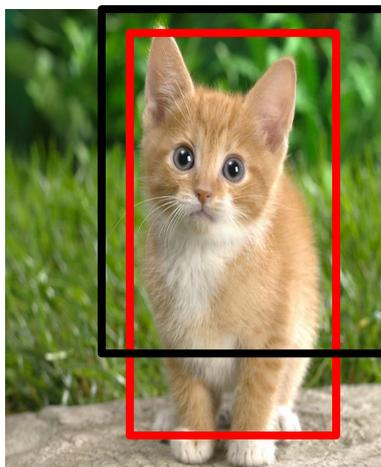

Larger image:
 $3 \times 257 \times 257$

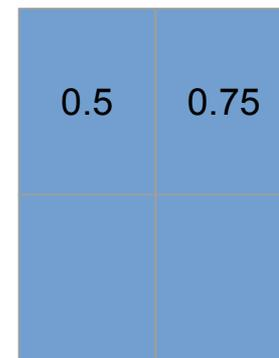

Classification scores:
P(cat)

Sliding Window: Overfeat

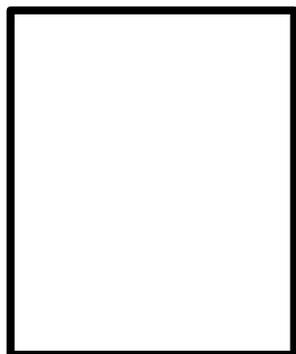

Network input:
3 x 221 x 221

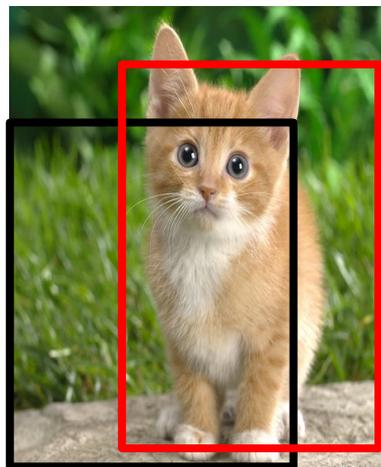

Larger image:
3 x 257 x 257

0.5	0.75
0.6	

Classification scores:
P(cat)

Sliding Window: Overfeat

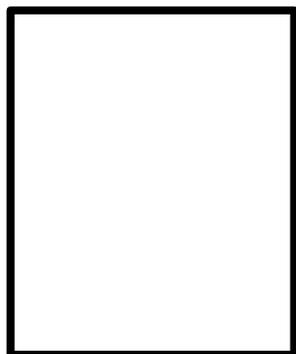

Network input:
3 x 221 x 221

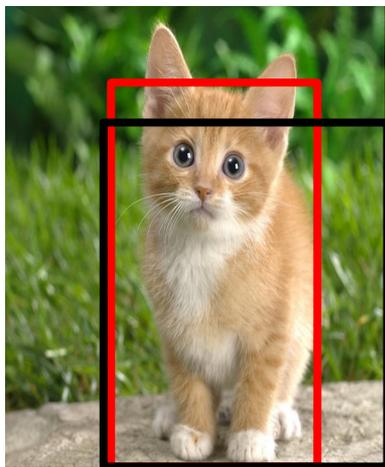

Larger image:
3 x 257 x 257

0.5	0.75
0.6	0.8

Classification scores:
P(cat)

Sliding Window: Overfeat

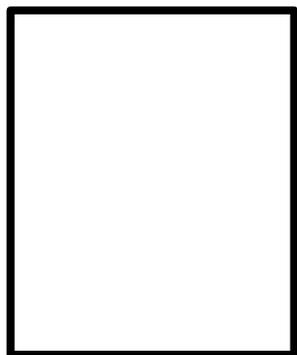

Network input:
3 x 221 x 221

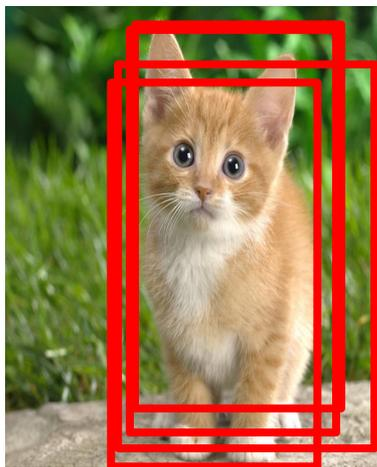

Larger image:
3 x 257 x 257

0.5	0.75
0.6	0.8

Classification scores:
P(cat)

Sliding Window: Overfeat

Greedily merge boxes and scores (details in paper)

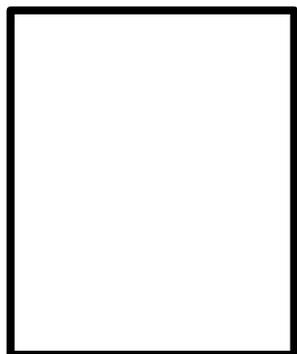

Network input:
3 x 221 x 221



Larger image:
3 x 257 x 257

0.8

Classification score:
P(cat)

Sliding Window: Overfeat

In practice use many sliding window locations and multiple scales

Window positions + score maps

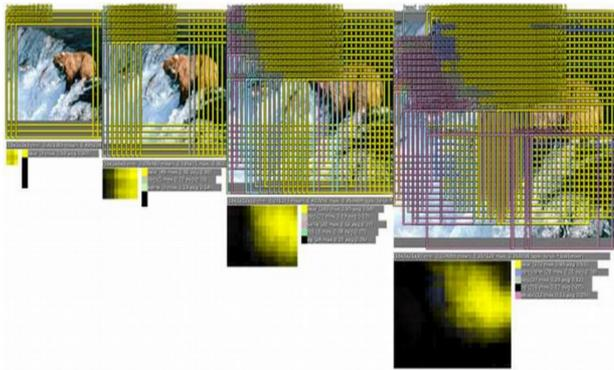

Box regression outputs



Final Predictions

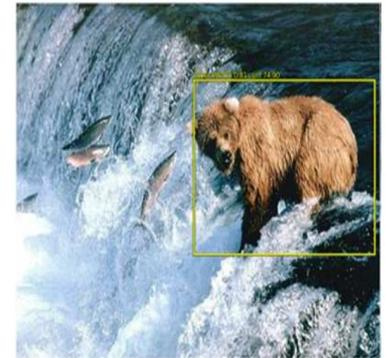

Sermanet et al, "Integrated Recognition, Localization and Detection using Convolutional Networks", ICLR 2014

Efficient Sliding Window: Overfeat

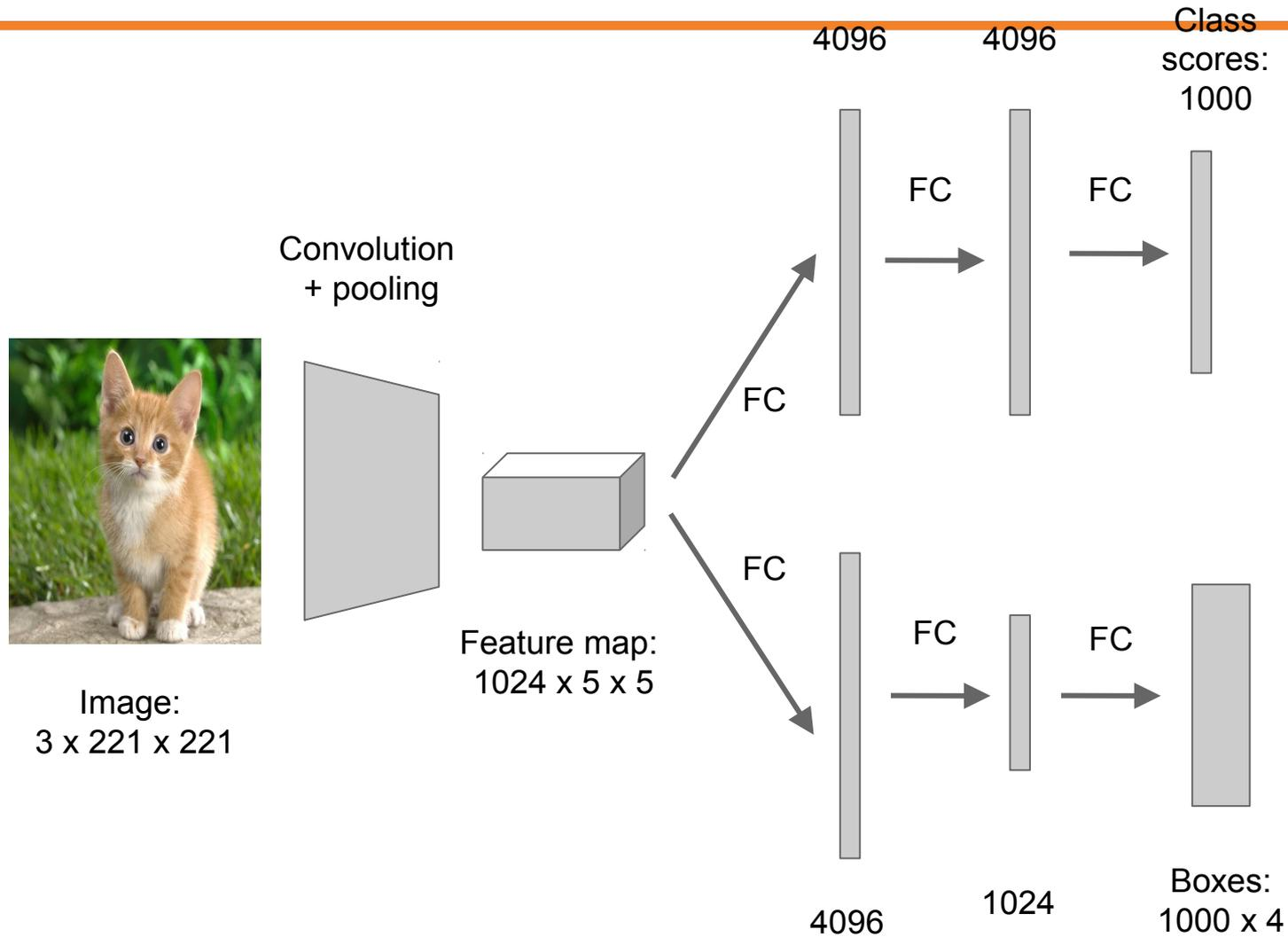

Efficient Sliding Window: Overfeat

Efficient sliding window by converting fully-connected layers into convolutions

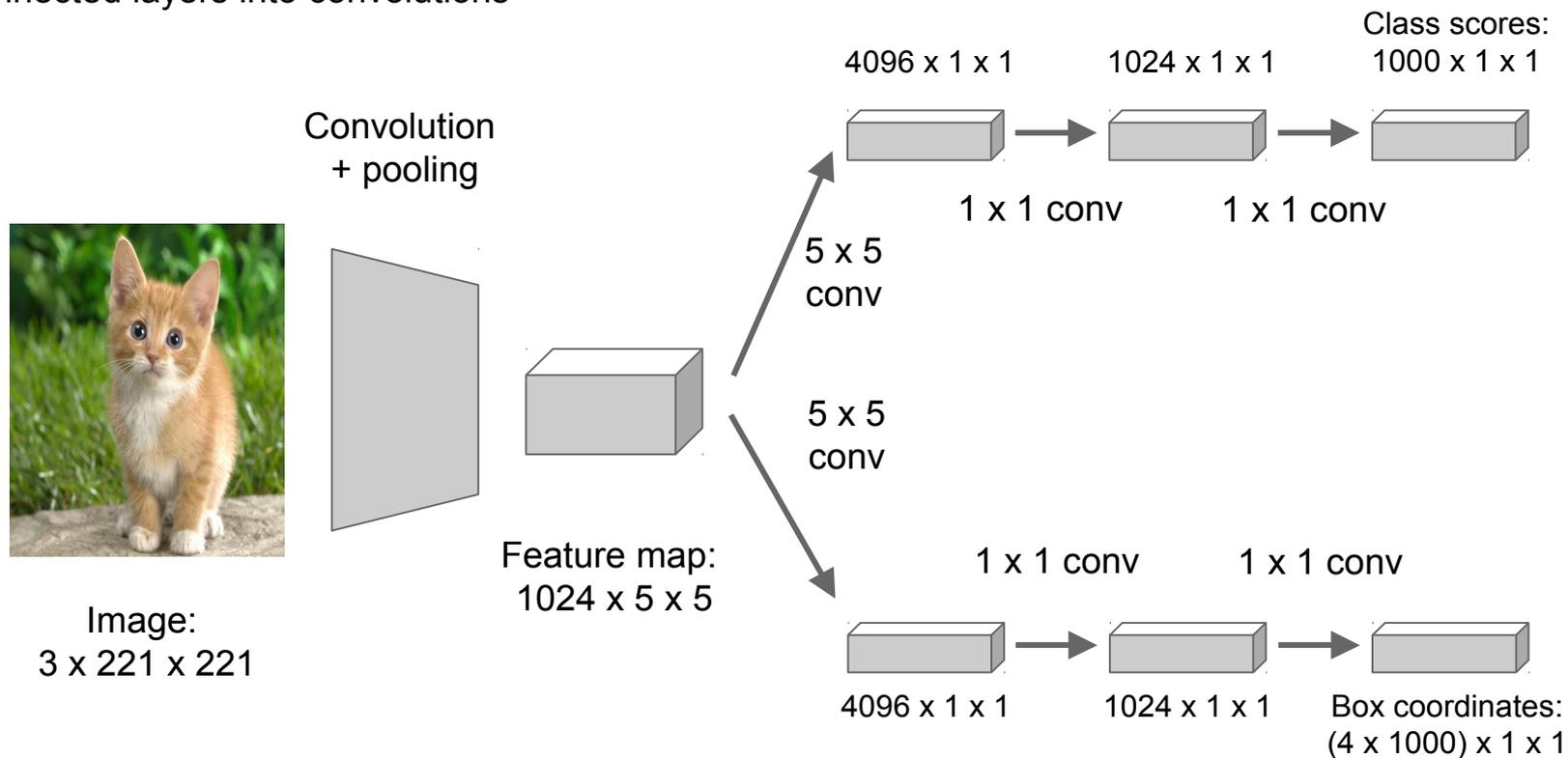

Efficient Sliding Window: Overfeat

Training time: Small image, 1 x 1 classifier output

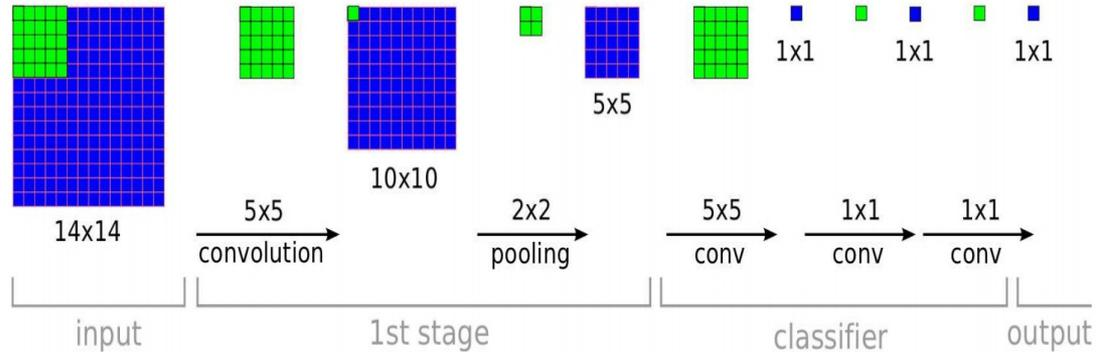

Test time: Larger image, 2 x 2 classifier output, only extra compute at yellow regions

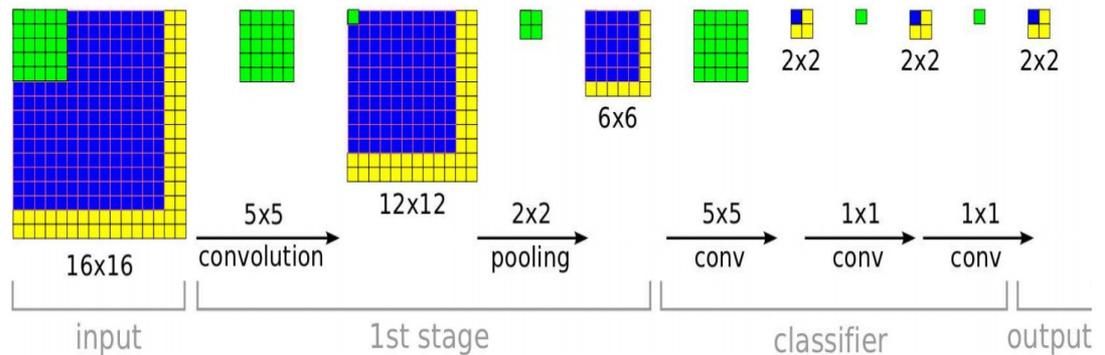

Sermanet et al, "Integrated Recognition, Localization and Detection using Convolutional Networks", ICLR 2014

ImageNet Classification + Localization

Localization Error (Top 5)

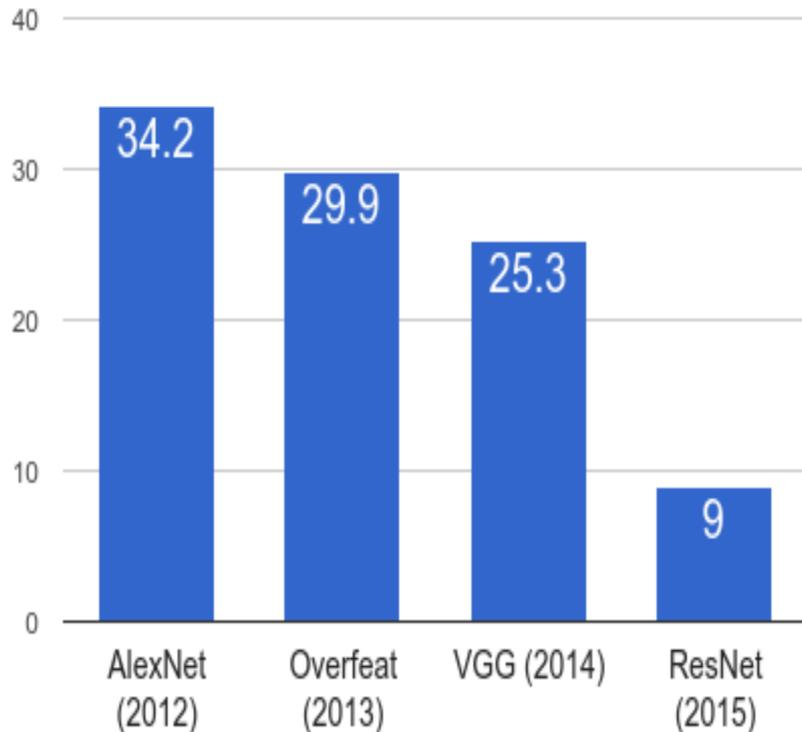

AlexNet: Localization method not published

Overfeat: Multiscale convolutional regression with box merging

VGG: Same as Overfeat, but fewer scales and locations; simpler method, gains all due to deeper features

ResNet: Different localization method (RPN) and much deeper features

Computer Vision Tasks

Classification

**Classification
+ Localization**

Object Detection

Instance
Segmentation

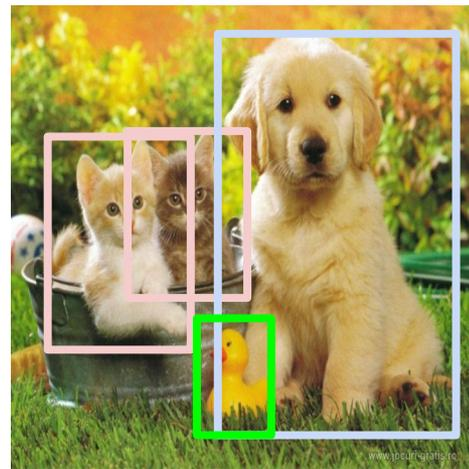

Computer Vision Tasks

Classification



Classification
+ Localization



Object Detection

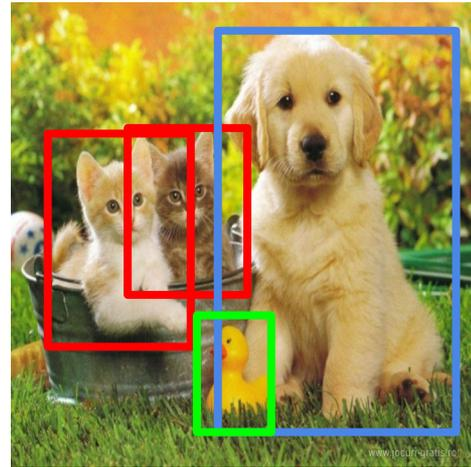

Instance
Segmentation



Detection as Regression?



DOG, (x, y, w, h)
CAT, (x, y, w, h)
CAT, (x, y, w, h)
DUCK (x, y, w, h)

= 16 numbers

Detection as Regression?



DOG, (x, y, w, h)
CAT, (x, y, w, h)

= 8 numbers

Detection as Regression?



CAT, (x, y, w, h)

CAT, (x, y, w, h)

....

CAT (x, y, w, h)

= many numbers

Need variable sized outputs

Detection as Classification



CAT? NO

DOG? NO

Detection as Classification



CAT? YES!

DOG? NO

Detection as Classification

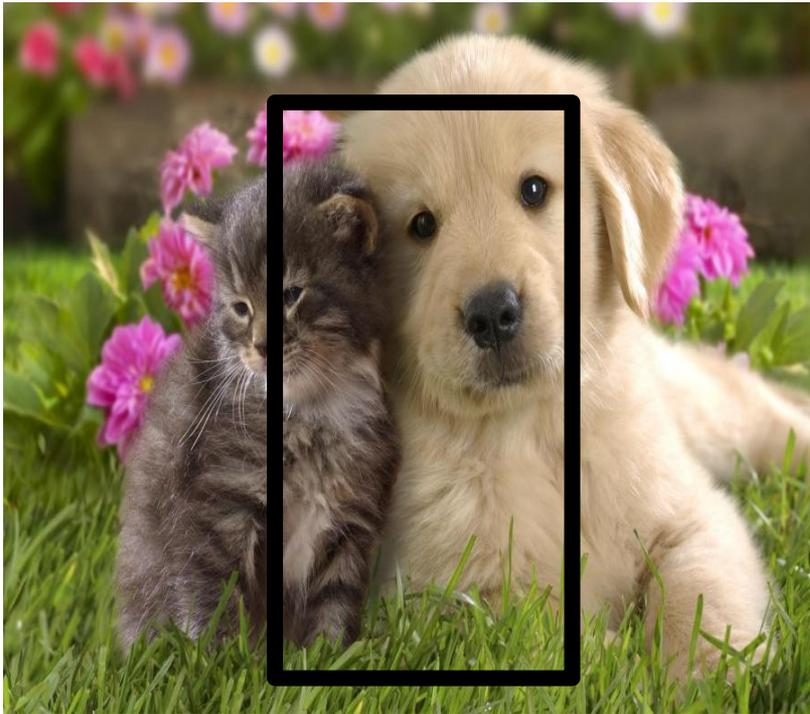

CAT? NO

DOG? NO

Detection as Classification

Problem: Need to test many positions and scales

Solution: If your classifier is fast enough, just do it

Histogram of Oriented Gradients

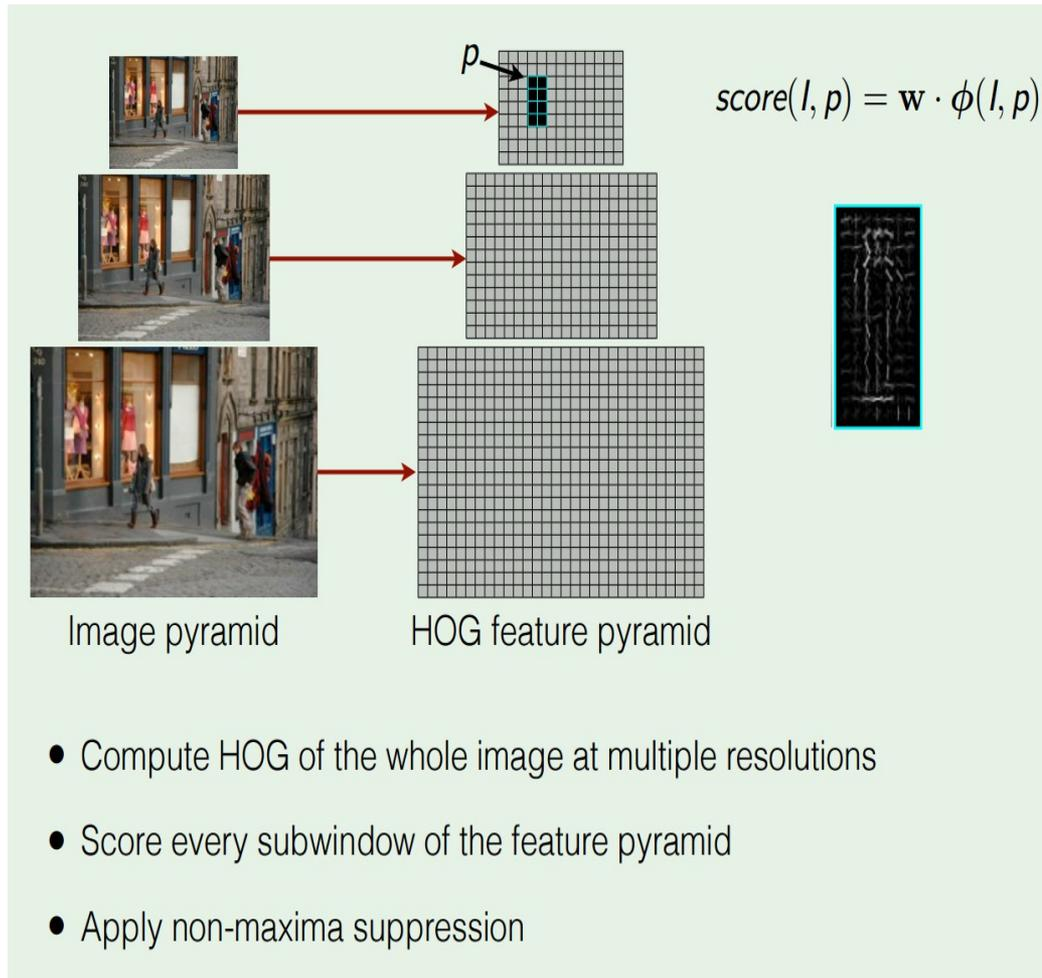

Dalal and Triggs, "Histograms of Oriented Gradients for Human Detection", CVPR 2005
Slide credit: Ross Girshick

Deformable Parts Model (DPM)

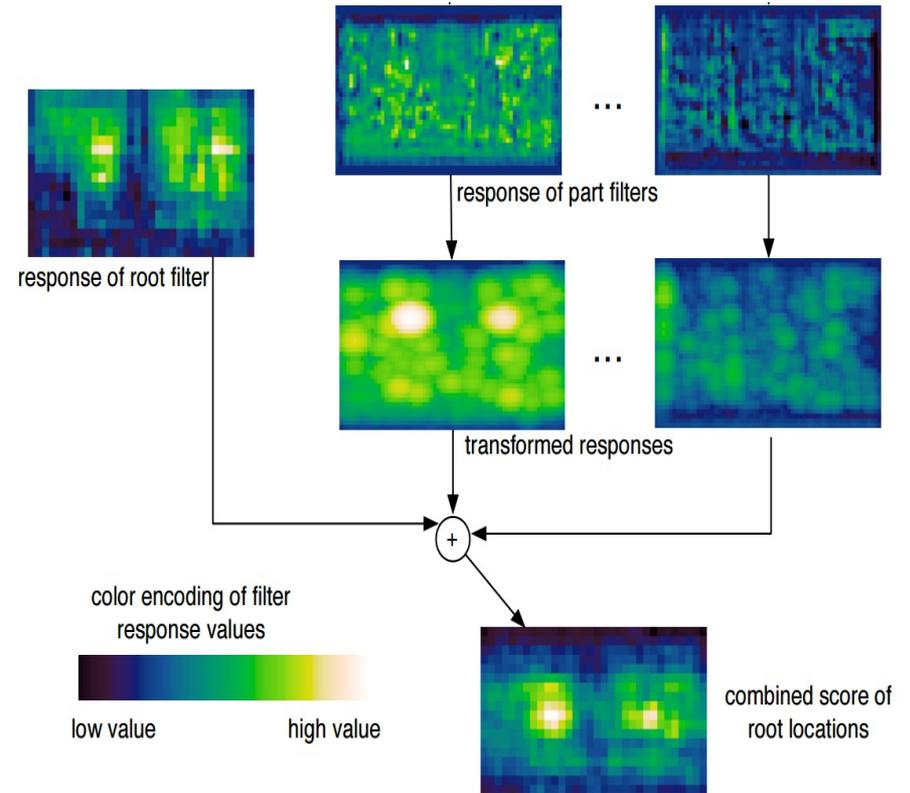
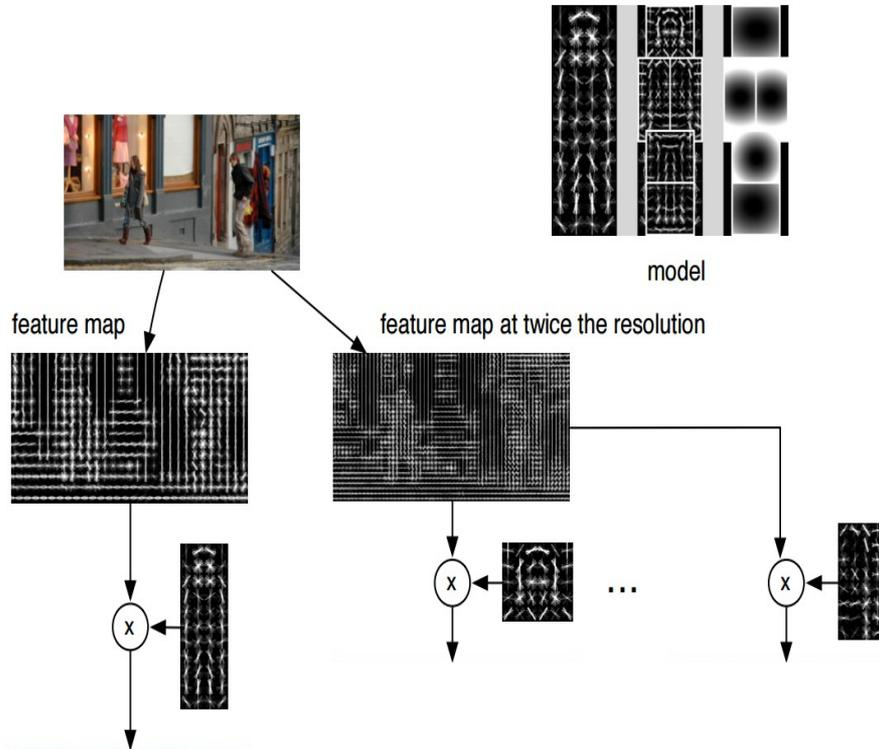

Felzenszwalb et al, "Object Detection with Discriminatively Trained Part Based Models", PAMI 2010

Aside: Deformable Parts Models are CNNs?

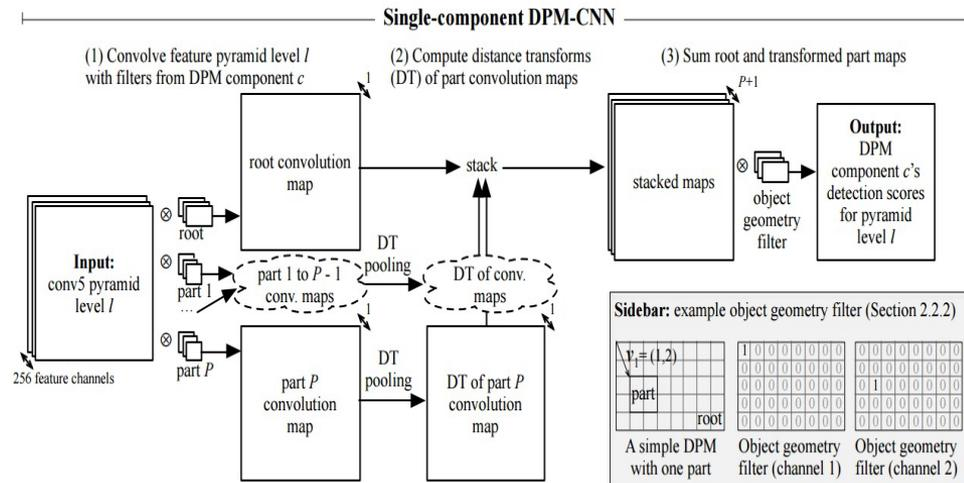
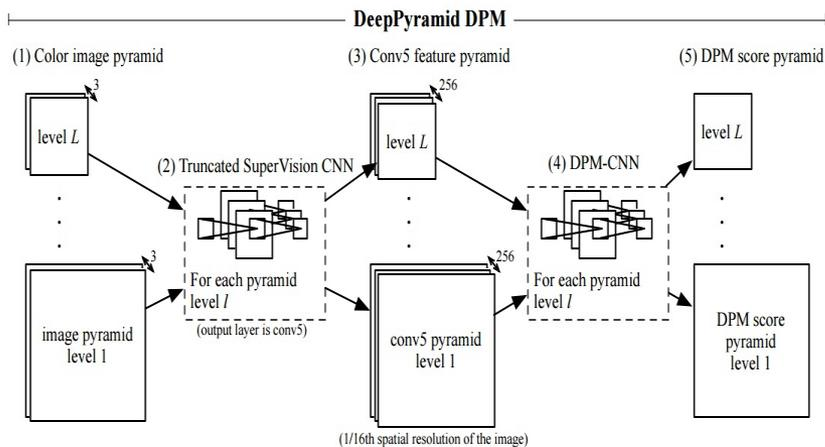

Girschick et al, "Deformable Part Models are Convolutional Neural Networks", CVPR 2015

Detection as Classification

Problem: Need to test many positions and scales, and use a computationally demanding classifier (CNN)

Solution: Only look at a tiny subset of possible positions

Region Proposals

- Find “blobby” image regions that are likely to contain objects
- “Class-agnostic” object detector
- Look for “blob-like” regions

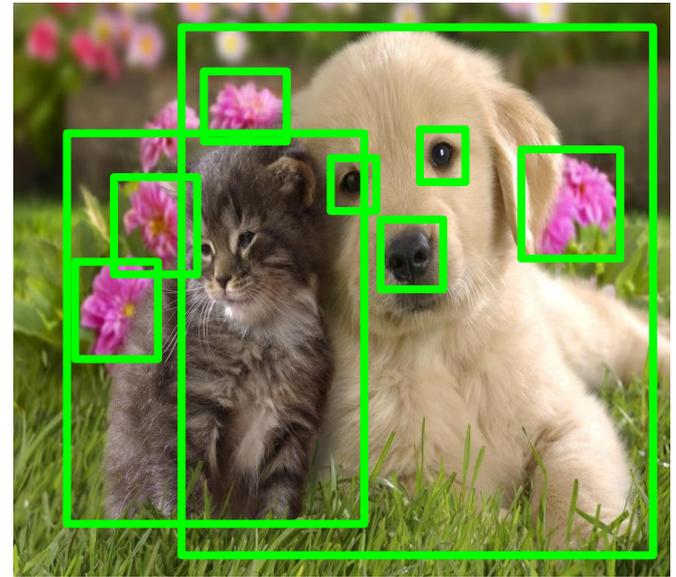

Region Proposals: Selective Search

Bottom-up segmentation, merging regions at multiple scales

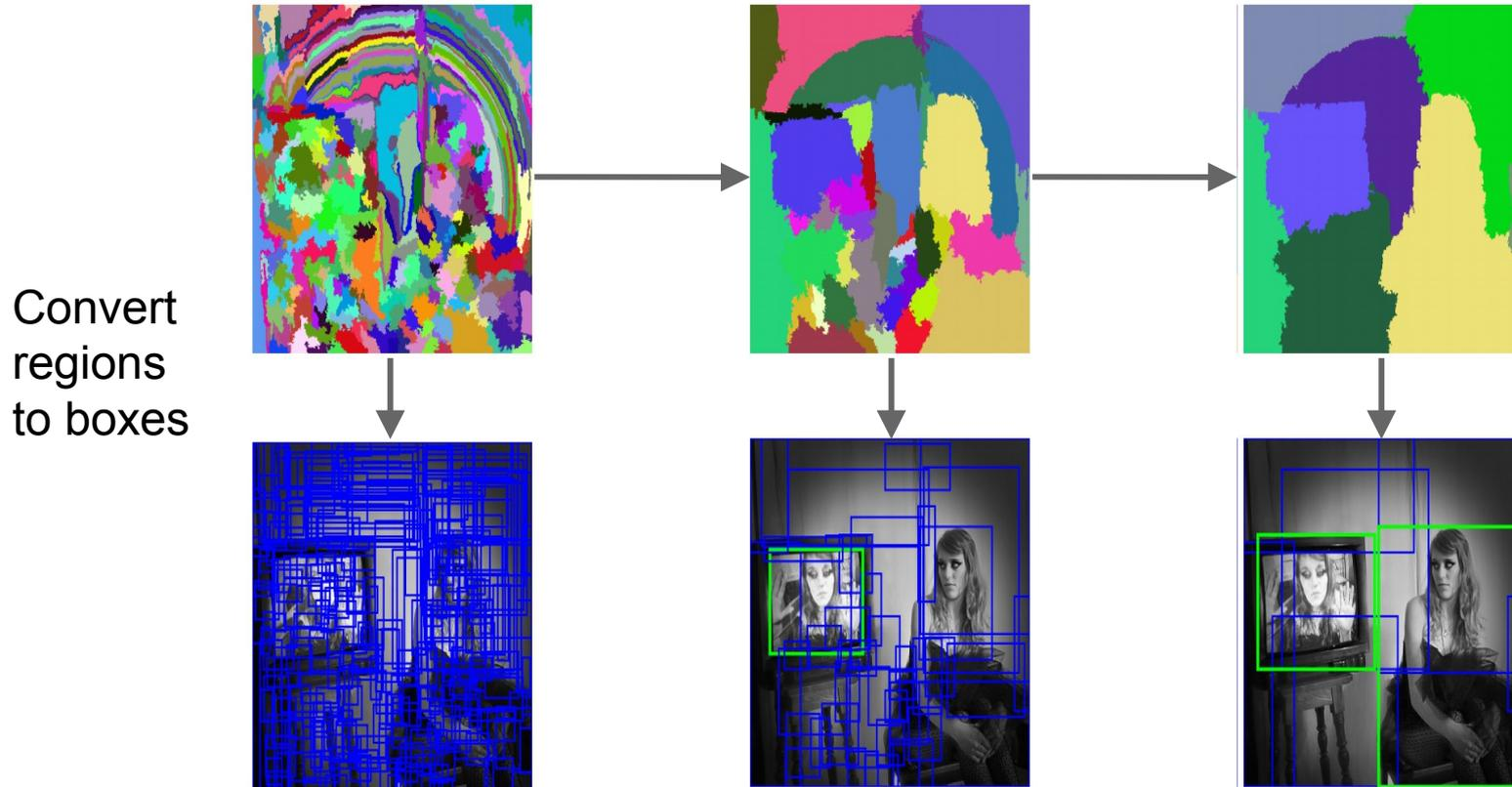

Uijlings et al, "Selective Search for Object Recognition", IJCV 2013

Region Proposals: Many other choices

Method	Approach	Outputs Segments	Outputs Score	Control #proposals	Time (sec.)	Repeatability	Recall Results	Detection Results
Bing [18]	Window scoring		✓	✓	0.2	***	*	.
CPMC [19]	Grouping	✓	✓	✓	250	-	**	*
EdgeBoxes [20]	Window scoring		✓	✓	0.3	**	***	***
Endres [21]	Grouping	✓	✓	✓	100	-	***	**
Geodesic [22]	Grouping	✓		✓	1	*	***	**
MCG [23]	Grouping	✓	✓	✓	30	*	***	***
Objectness [24]	Window scoring		✓	✓	3	.	*	.
Rahtu [25]	Window scoring		✓	✓	3	.	.	*
RandomizedPrim's [26]	Grouping	✓		✓	1	*	*	**
Rantalankila [27]	Grouping	✓		✓	10	**	.	**
Rigor [28]	Grouping	✓		✓	10	*	**	**
SelectiveSearch [29]	Grouping	✓	✓	✓	10	**	***	***
Gaussian				✓	0	.	.	*
SlidingWindow				✓	0	***	.	.
Superpixels		✓			1	*	.	.
Uniform				✓	0	.	.	.

Hosang et al, "What makes for effective detection proposals?", PAMI 2015

Region Proposals: Many other choices

Method	Approach	Outputs Segments	Outputs Score	Control #proposals	Time (sec.)	Repeatability	Recall Results	Detection Results
Bing [18]	Window scoring		✓	✓	0.2	***	*	.
CPMC [19]	Grouping	✓	✓	✓	250	-	**	*
EdgeBoxes [20]	Window scoring		✓	✓	0.3	**	***	***
Endres [21]	Grouping	✓	✓	✓	100	-	***	**
Geodesic [22]	Grouping	✓		✓	1	*	***	**
MCG [23]	Grouping	✓	✓	✓	30	*	***	***
Objectness [24]	Window scoring		✓	✓	3	.	*	.
Rahtu [25]	Window scoring		✓	✓	3	.	.	*
RandomizedPrim's [26]	Grouping	✓		✓	1	*	*	**
Rantalankila [27]	Grouping	✓		✓	10	**	.	**
Rigor [28]	Grouping	✓		✓	10	*	**	**
SelectiveSearch [29]	Grouping	✓	✓	✓	10	**	***	***
Gaussian				✓	0	.	.	*
SlidingWindow				✓	0	***	.	.
Superpixels		✓			1	*	.	.
Uniform				✓	0	.	.	.

Hosang et al, "What makes for effective detection proposals?", PAMI 2015

Putting it together: R-CNN

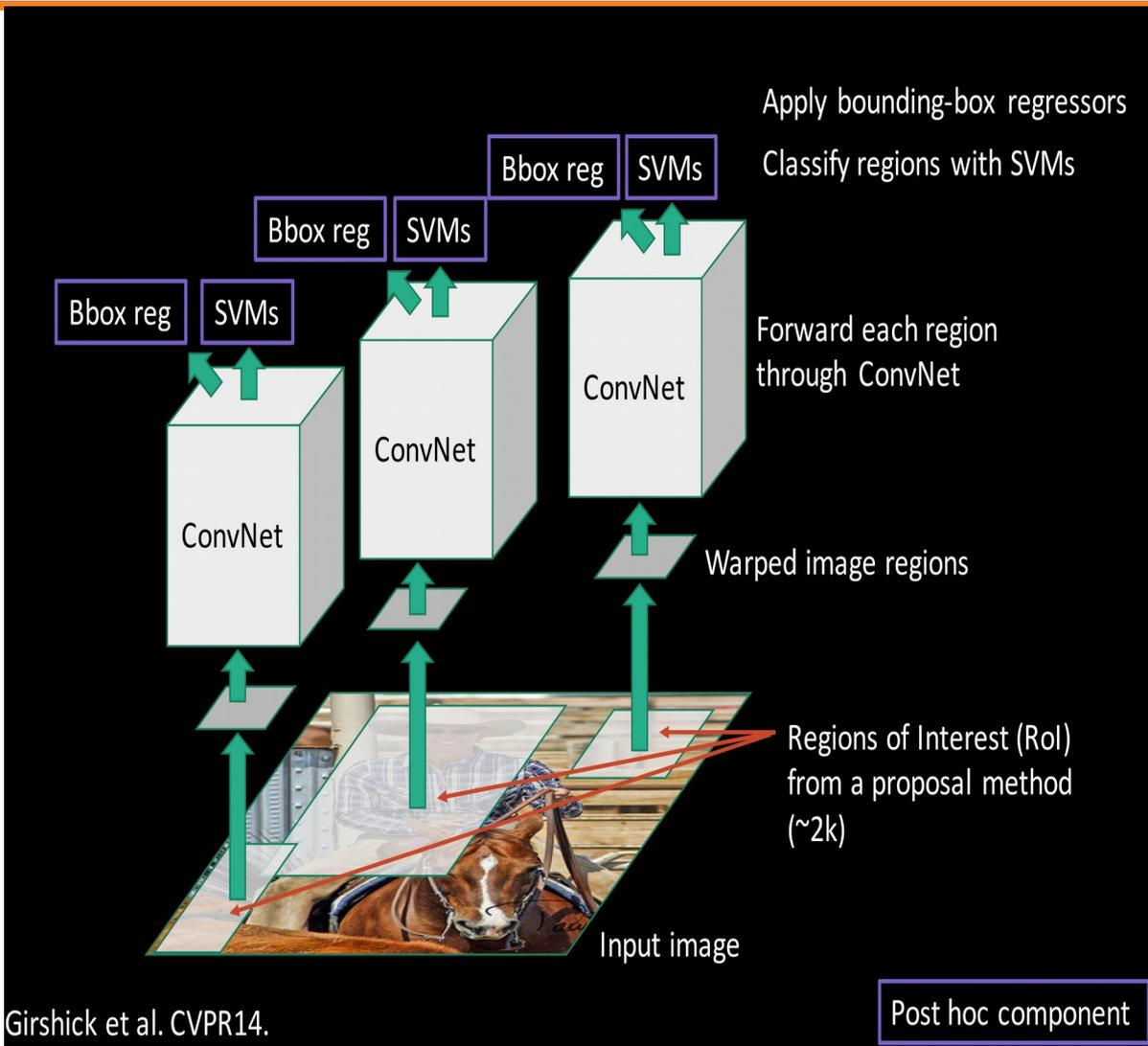

Girshick et al, "Rich feature hierarchies for accurate object detection and semantic segmentation", CVPR 2014

Slide credit: Ross Girshick

R-CNN Training

Step 1: Train (or download) a classification model for ImageNet (AlexNet)

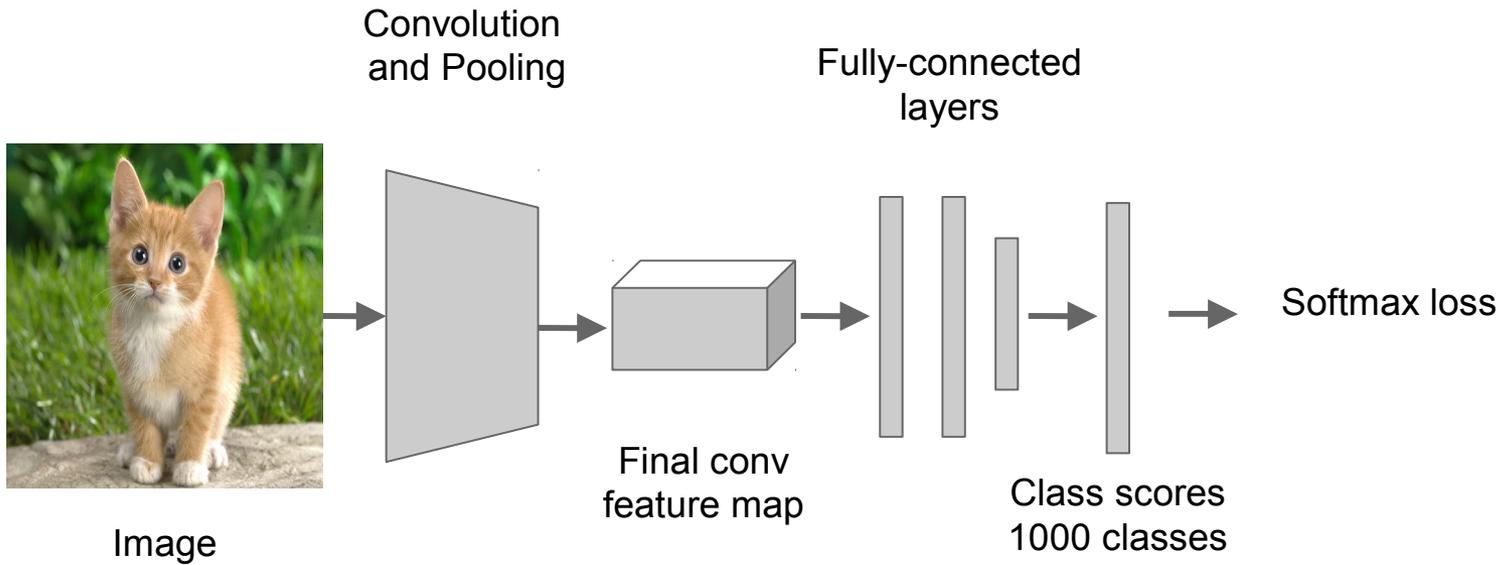

R-CNN Training

Step 2: Fine-tune model for detection

- Instead of 1000 ImageNet classes, want 20 object classes + background
- Throw away final fully-connected layer, reinitialize from scratch
- Keep training model using positive / negative regions from detection images

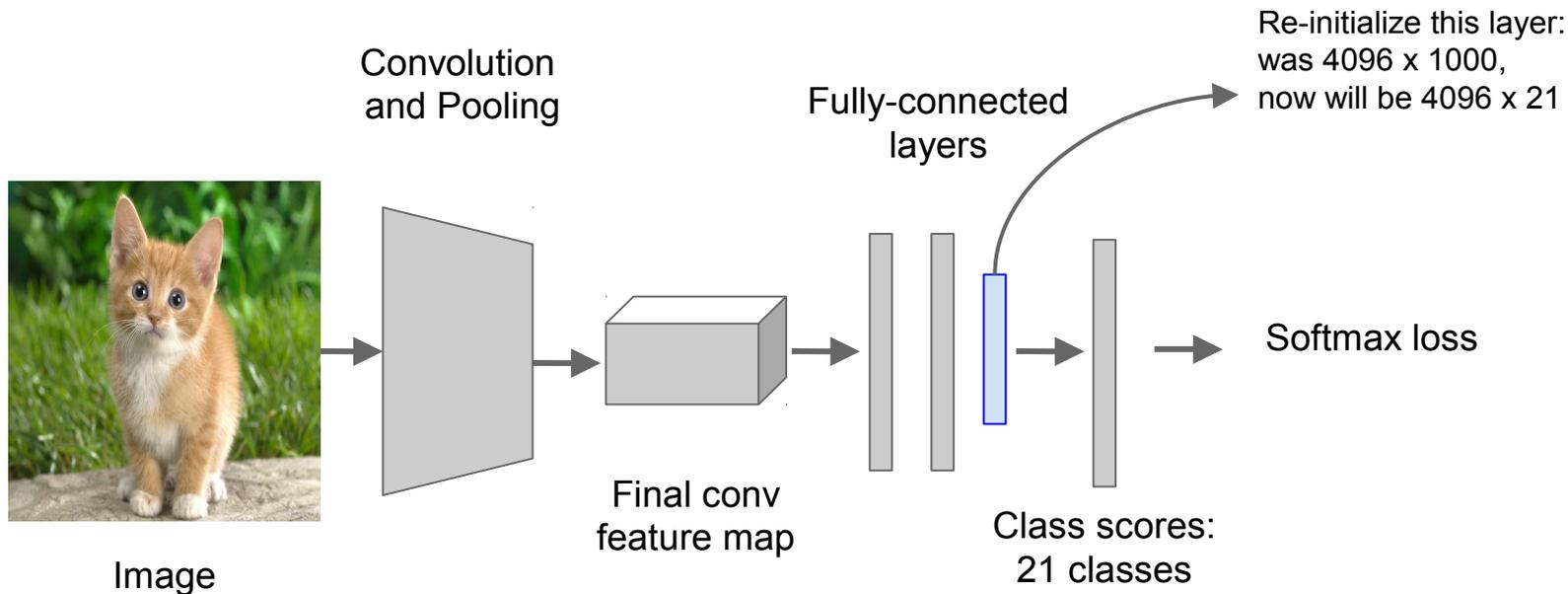

R-CNN Training

Step 3: Extract features

- Extract region proposals for all images
- For each region: warp to CNN input size, run forward through CNN, save pool5 features to disk
- Have a big hard drive: features are ~200GB for PASCAL dataset!



Image

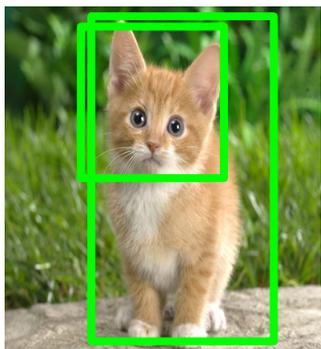

Region Proposals



Crop + Warp

Convolution
and Pooling

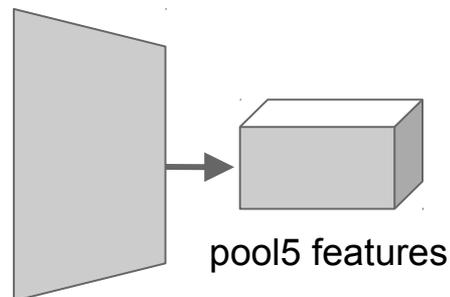

Forward pass



Save to disk

R-CNN Training

Step 4: Train one binary SVM per class to classify region features

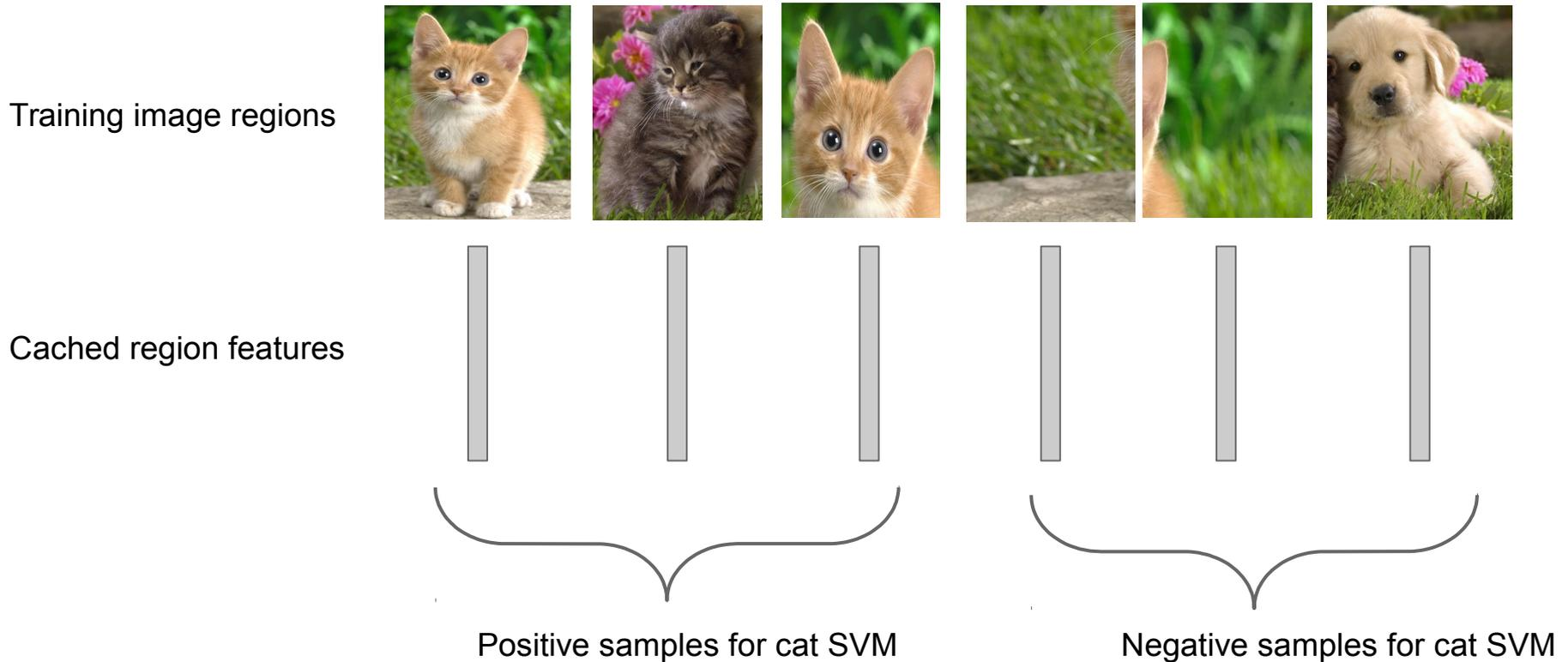

R-CNN Training

Step 4: Train one binary SVM per class to classify region features

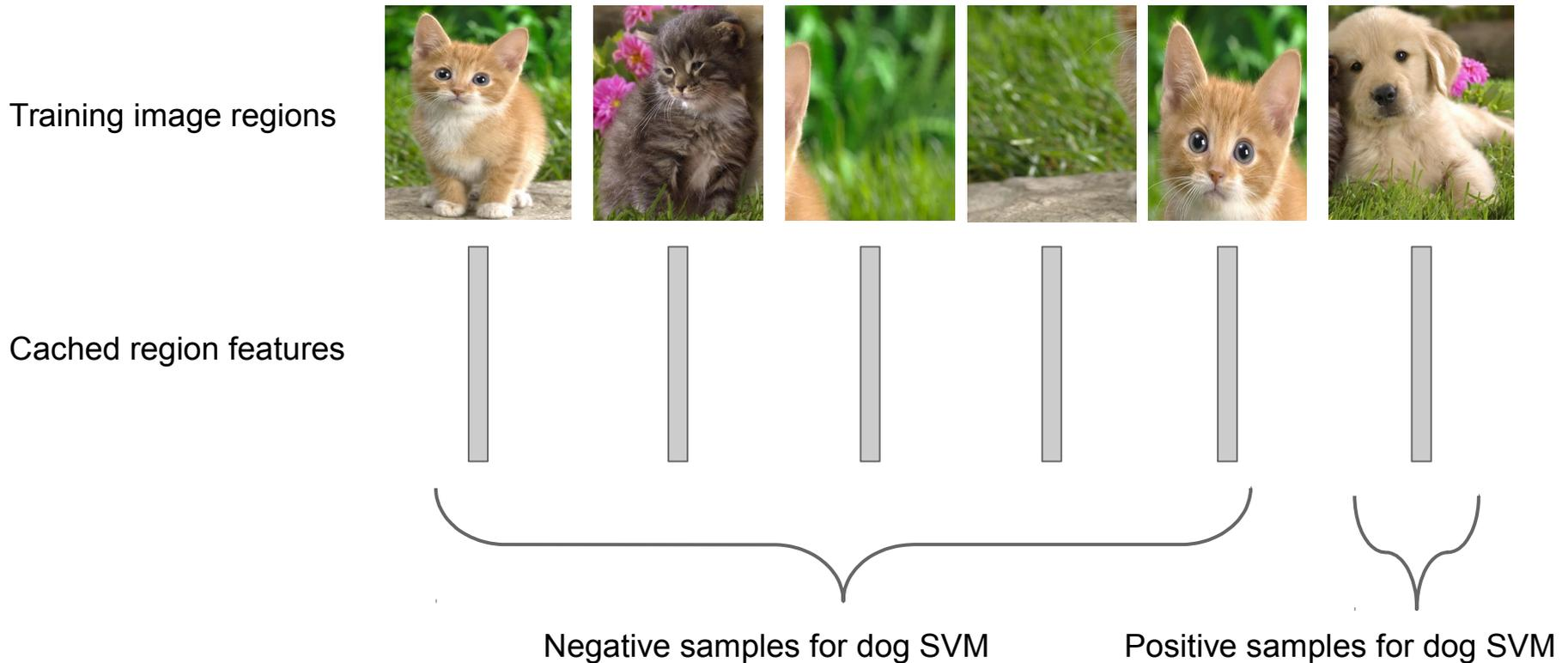

R-CNN Training

Step 5 (bbox regression): For each class, train a linear regression model to map from cached features to offsets to GT boxes to make up for “slightly wrong” proposals

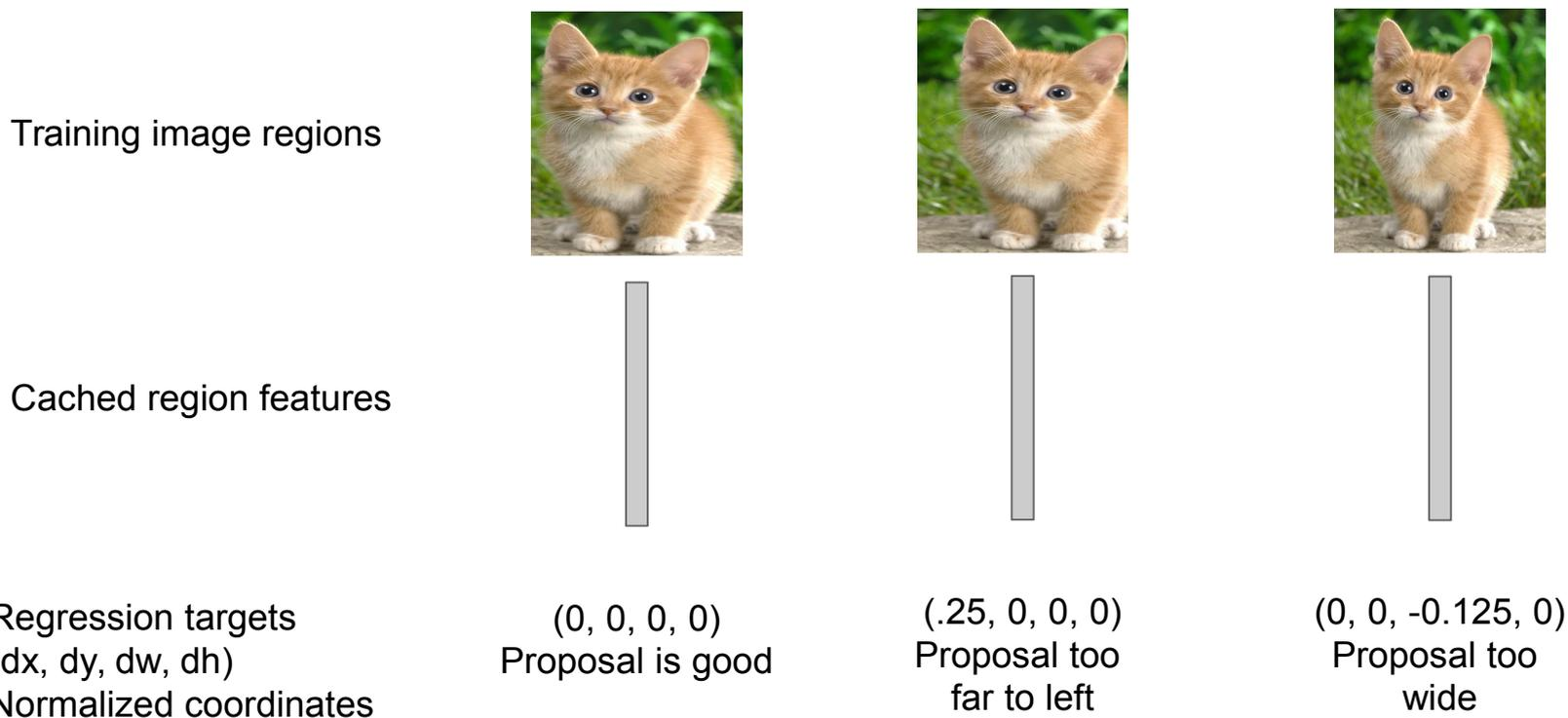

Object Detection: Datasets

	PASCAL VOC (2010)	ImageNet Detection (ILSVRC 2014)	MS-COCO (2014)
Number of classes	20	200	80
Number of images (train + val)	~20k	~470k	~120k
Mean objects per image	2.4	1.1	7.2

Object Detection: Evaluation

We use a metric called “mean average precision” (mAP)

Compute average precision (AP) separately for each class, then average over classes

A detection is a true positive if it has IoU with a ground-truth box greater than some threshold (usually 0.5) (mAP@0.5)

Combine all detections from all test images to draw a precision / recall curve for each class; AP is area under the curve

TL;DR mAP is a number from 0 to 100; high is good

R-CNN Results

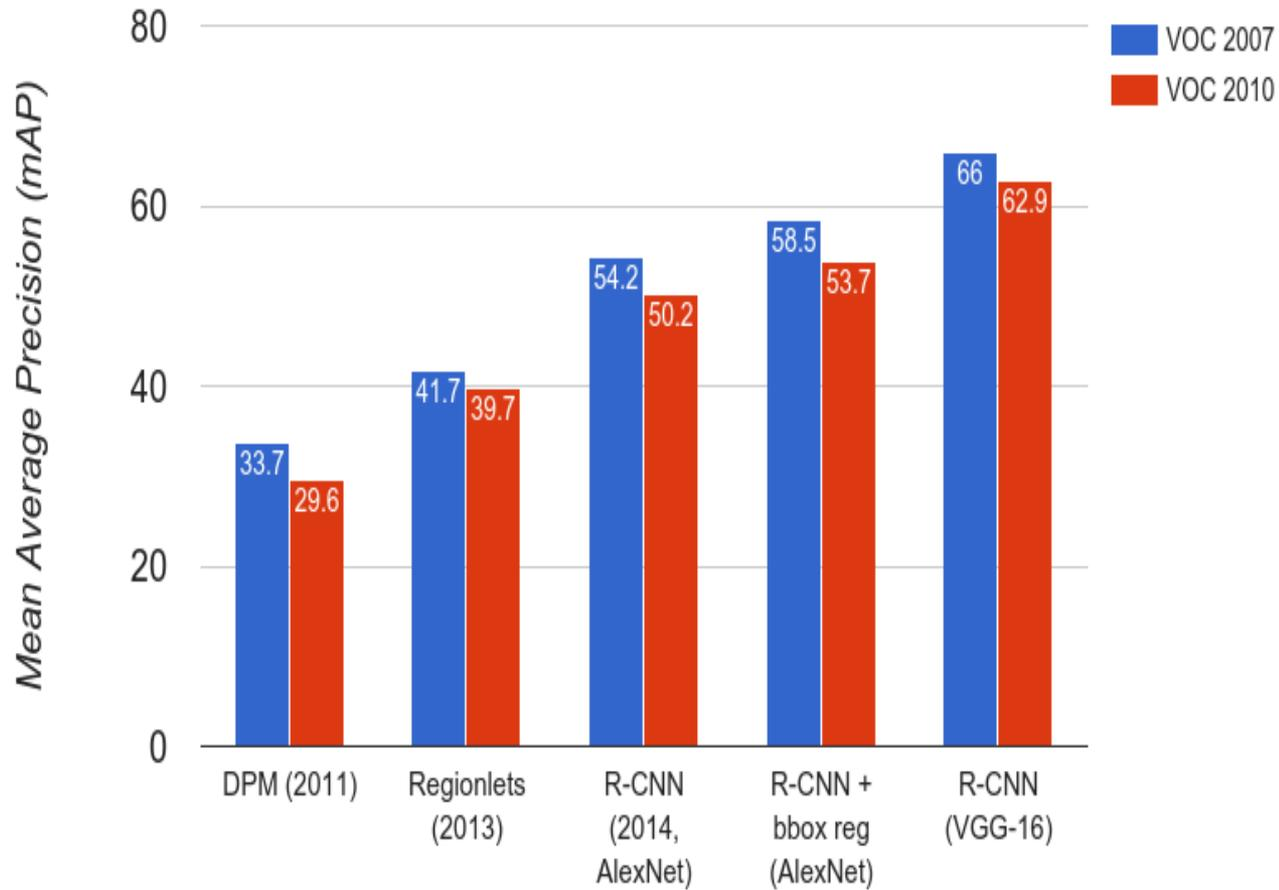

Wang et al, "Regionlets for Generic Object Detection", ICCV 2013

R-CNN Results

Big improvement compared to pre-CNN methods

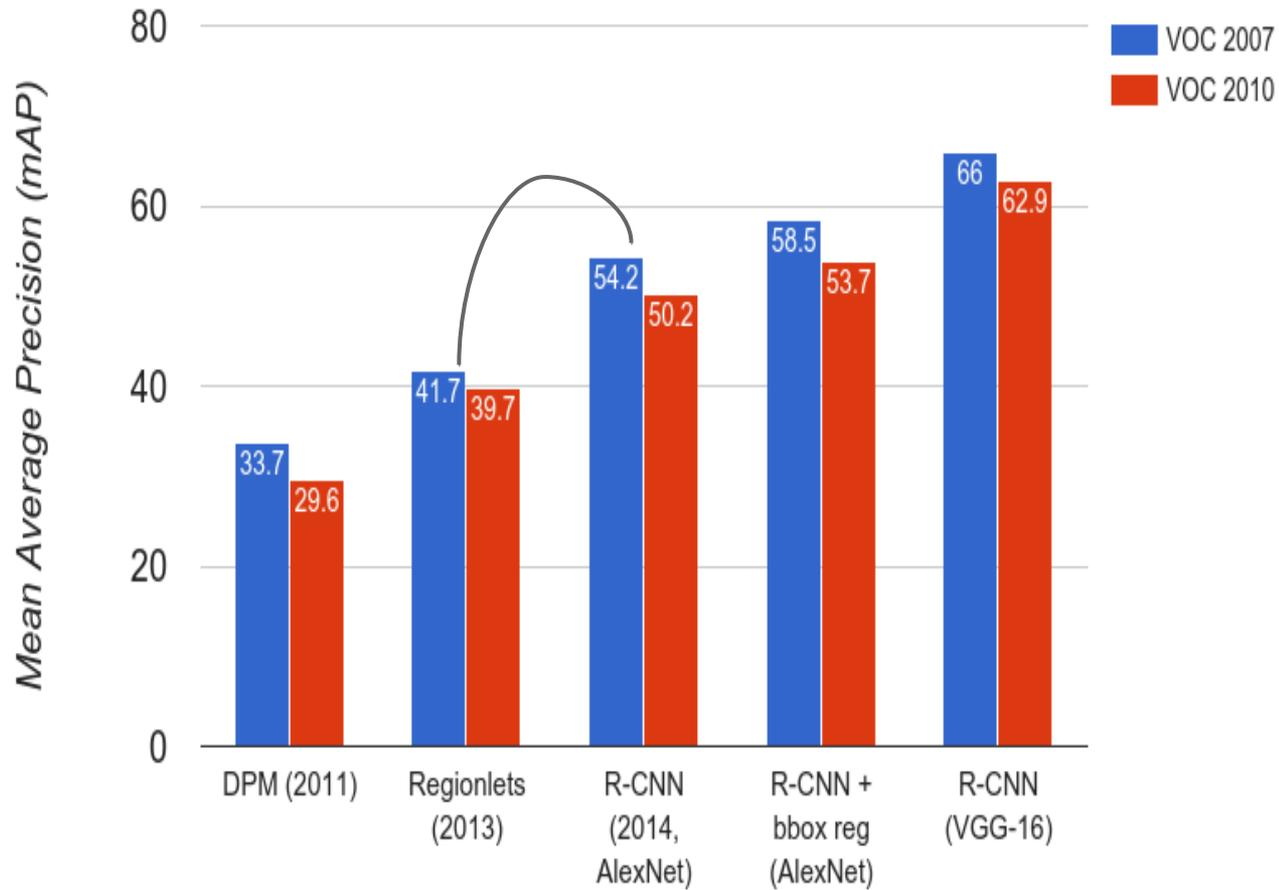

R-CNN Results

Bounding box regression helps a bit

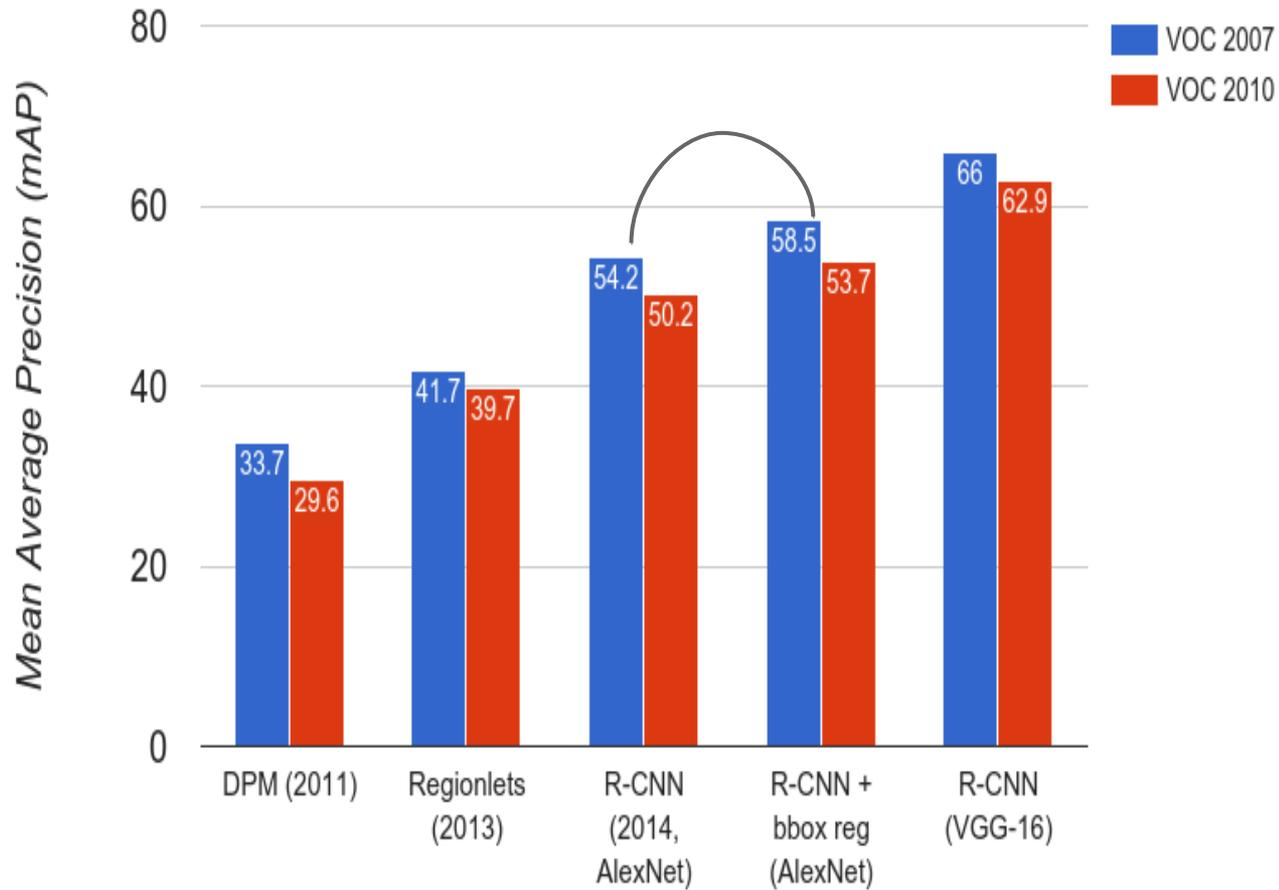

R-CNN Results

Features from a deeper network help a lot

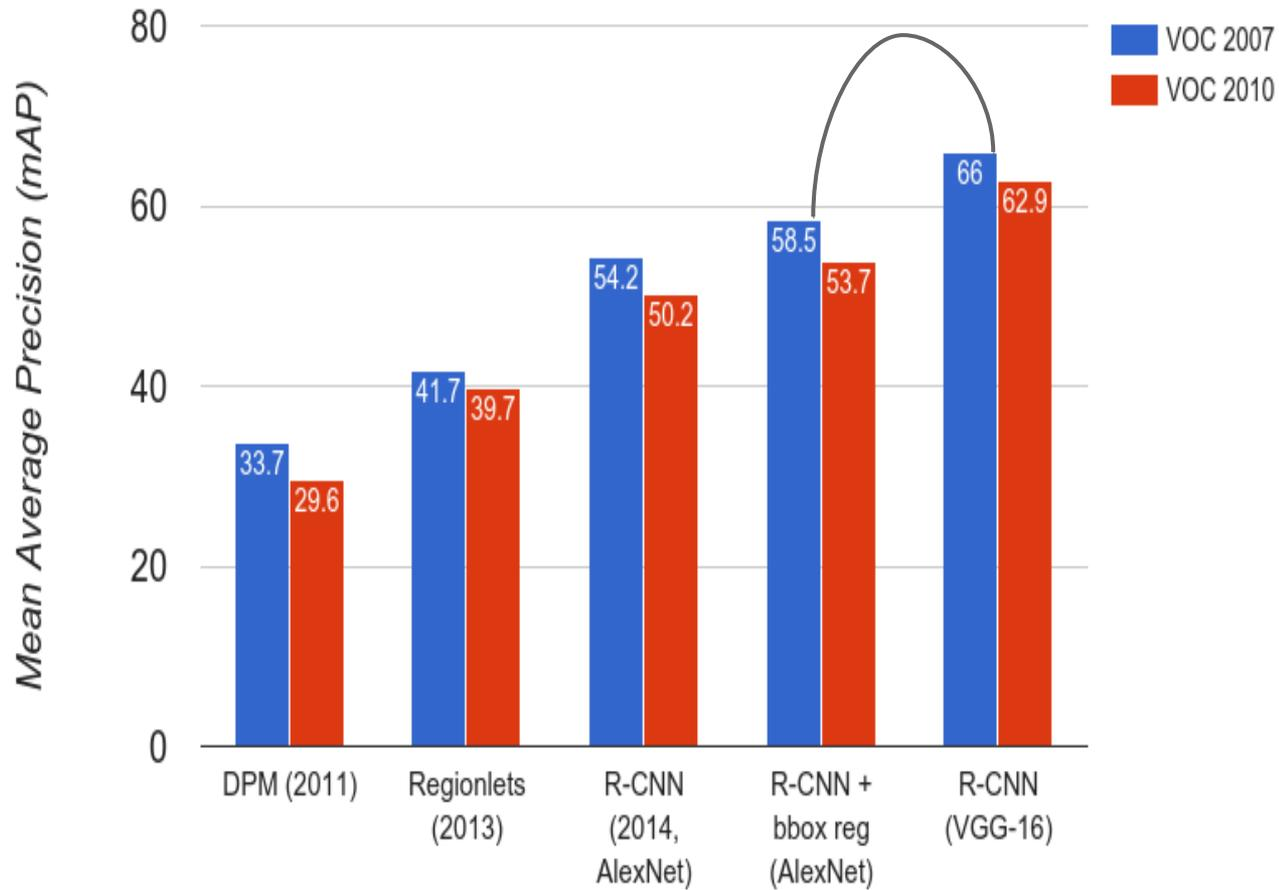

R-CNN Problems

1. Slow at test-time: need to run full forward pass of CNN for each region proposal
2. SVMs and regressors are post-hoc: CNN features not updated in response to SVMs and regressors
3. Complex multistage training pipeline

Fast R-CNN (test time)

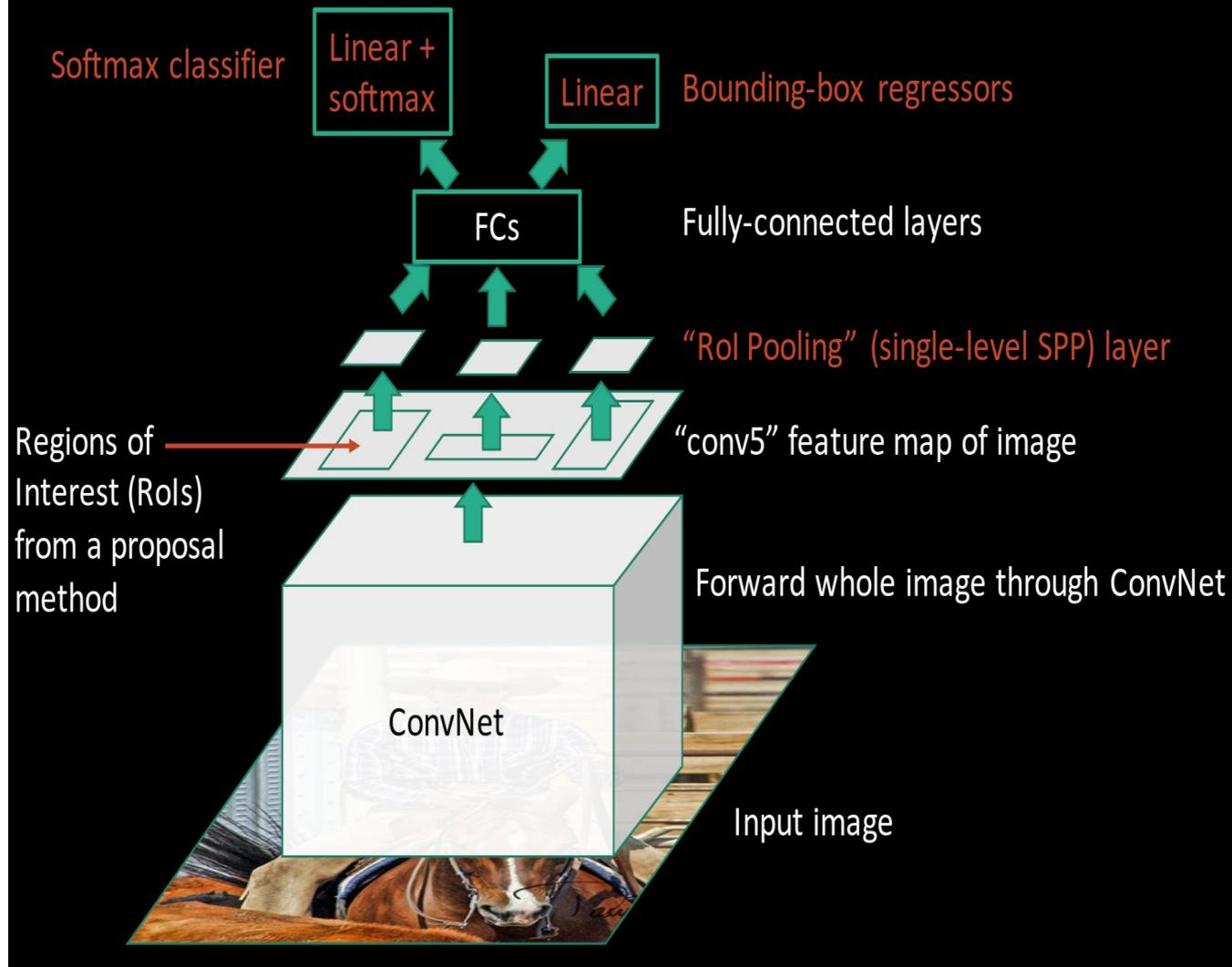

Girschick, "Fast R-CNN", ICCV 2015

Slide credit: Ross Girschick

Fast R-CNN (test time)

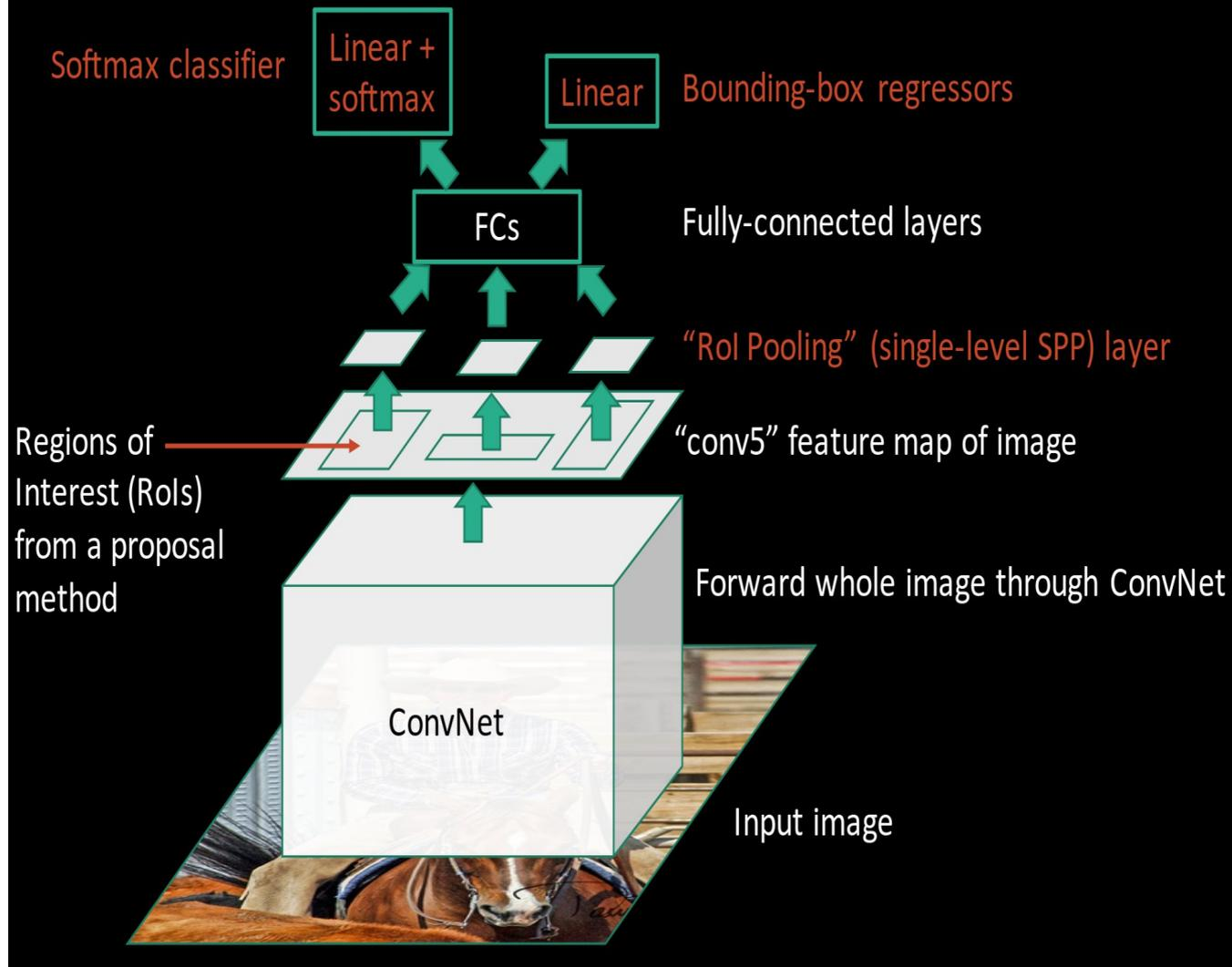

R-CNN Problem #1:
Slow at test-time due to independent forward passes of the CNN

Solution:
Share computation of convolutional layers between proposals for an image

Fast R-CNN (training)

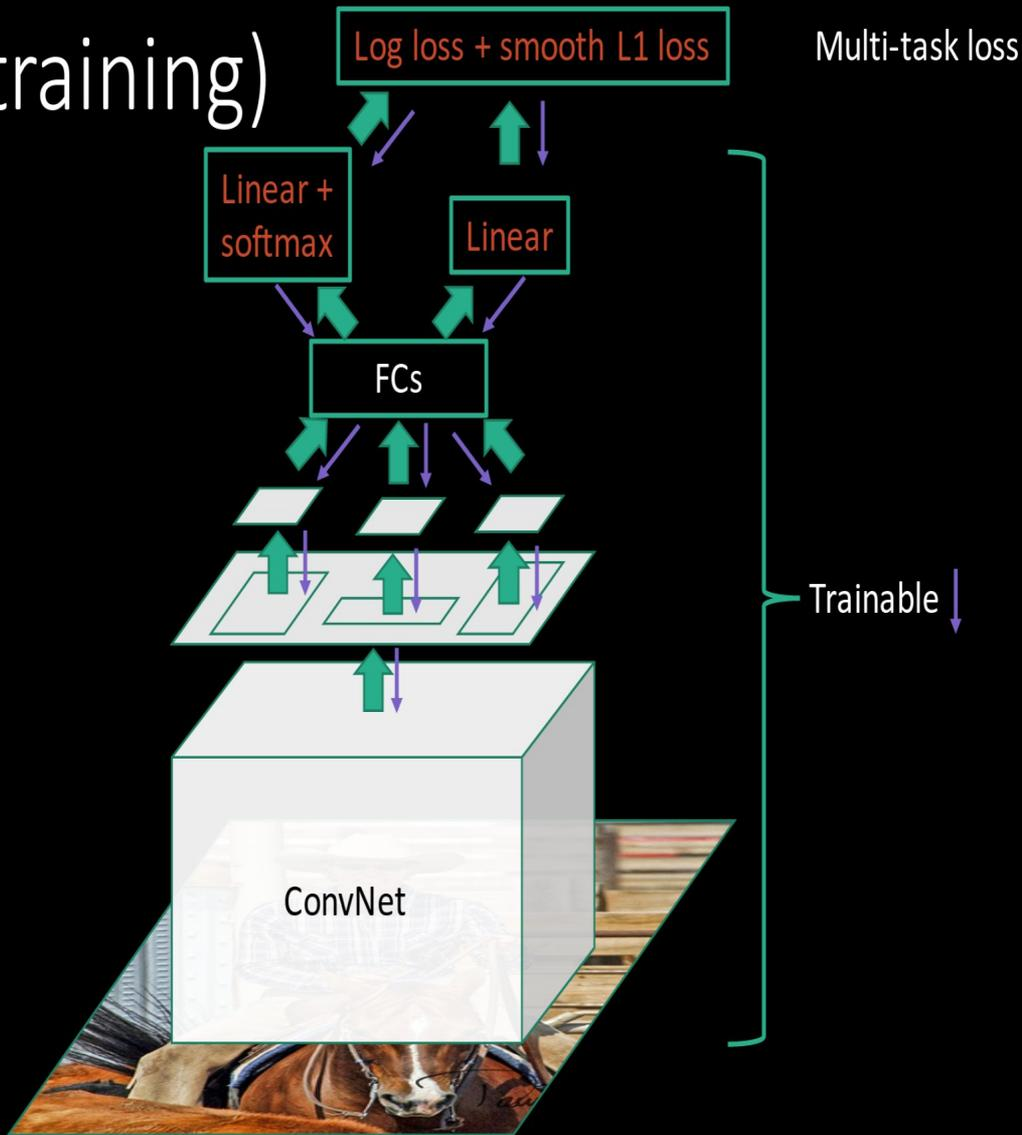

R-CNN Problem #2:

Post-hoc training: CNN not updated in response to final classifiers and regressors

R-CNN Problem #3:

Complex training pipeline

Solution:

Just train the whole system end-to-end all at once!

Slide credit: Ross Girschick

Fast R-CNN: Region of Interest Pooling

Convolution
and Pooling



Hi-res input
image:
 $3 \times 800 \times 600$
with region
proposal

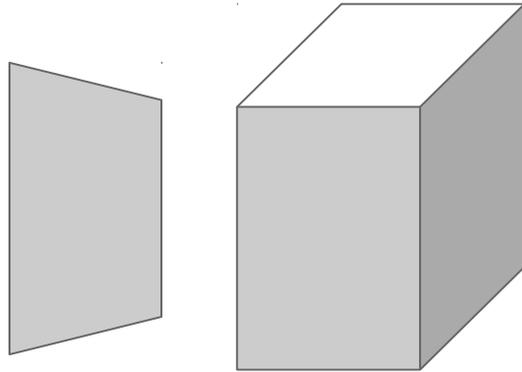

Hi-res conv features:
 $C \times H \times W$
with region proposal

Fully-connected
layers

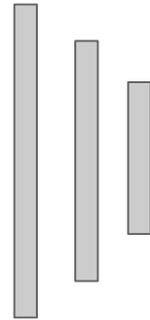

Problem: Fully-connected
layers expect low-res conv
features: $C \times h \times w$

Fast R-CNN: Region of Interest Pooling

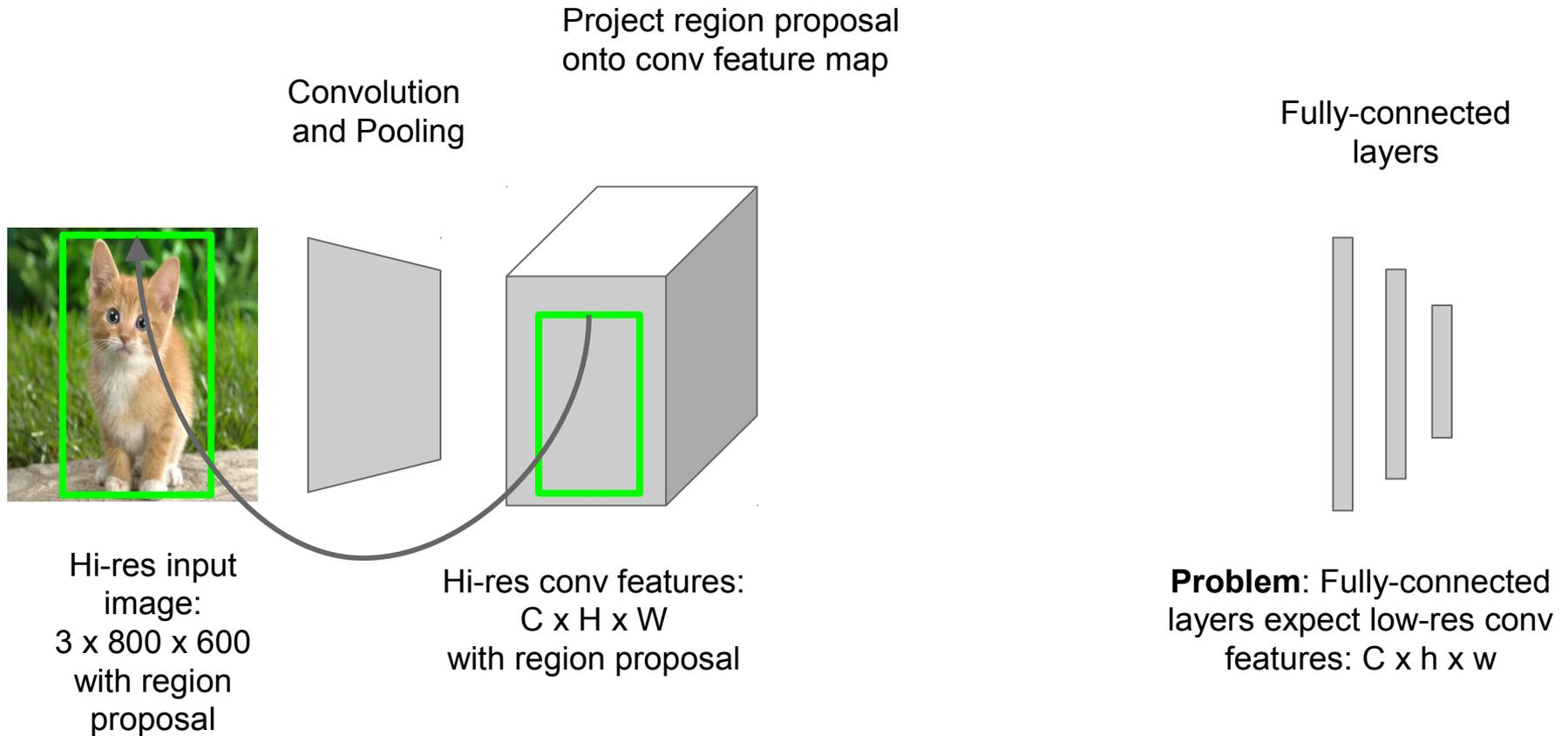

Fast R-CNN: Region of Interest Pooling

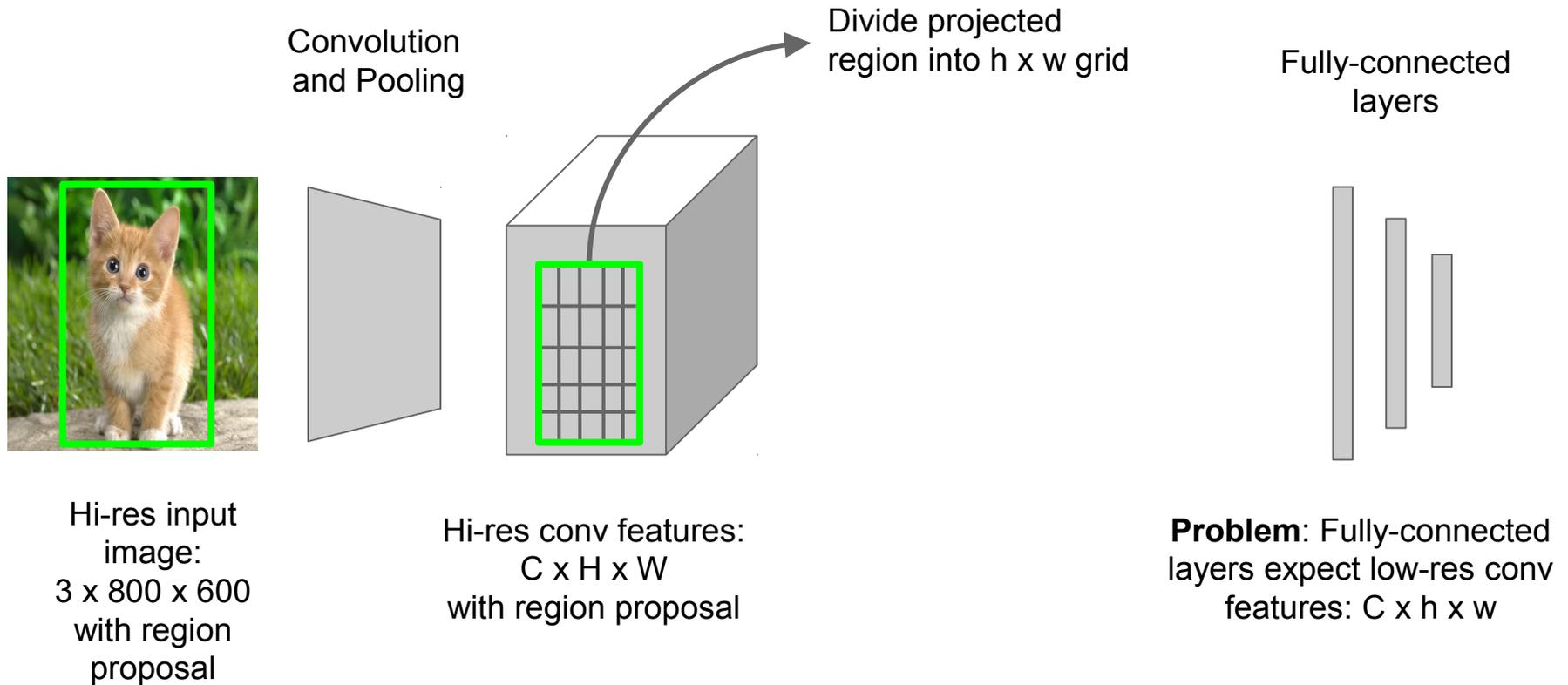

Fast R-CNN: Region of Interest Pooling

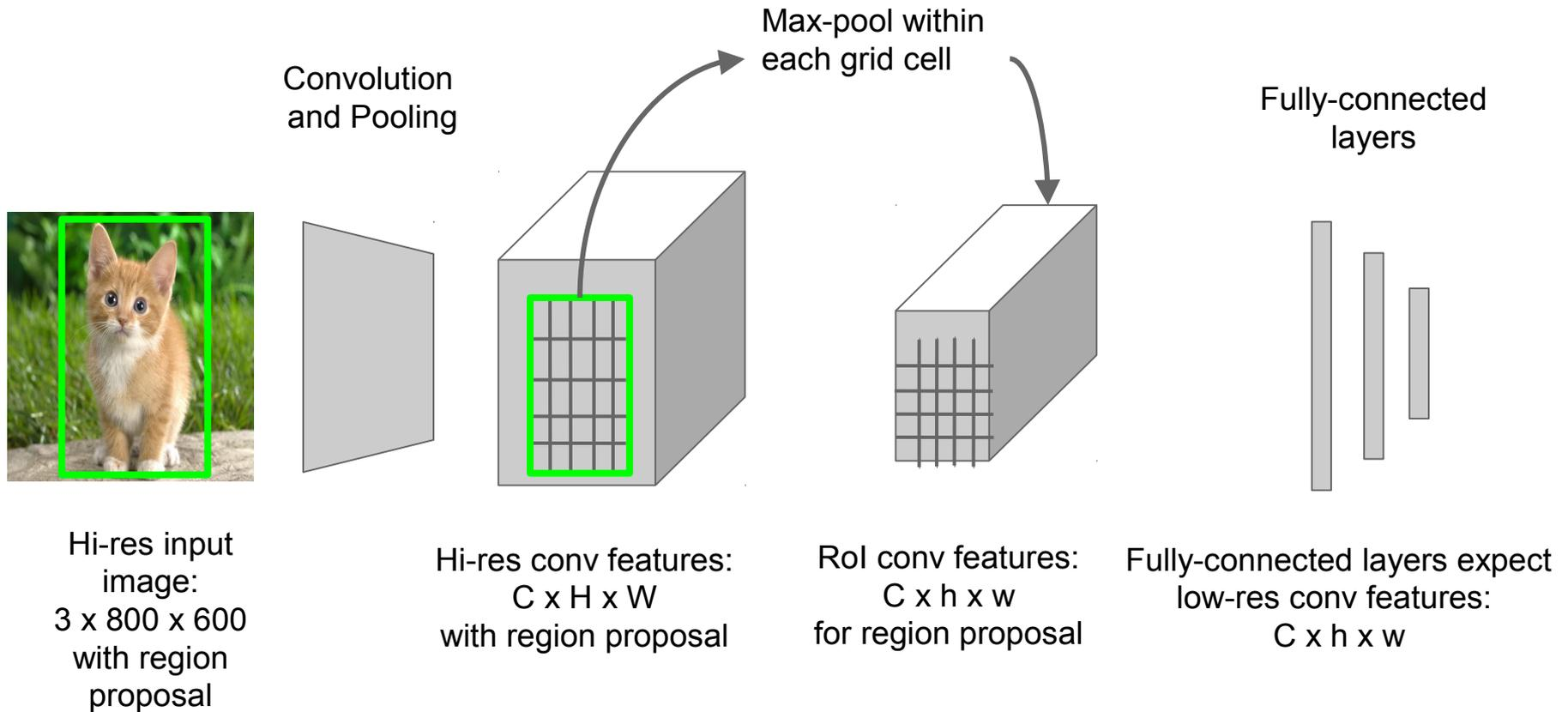

Fast R-CNN: Region of Interest Pooling

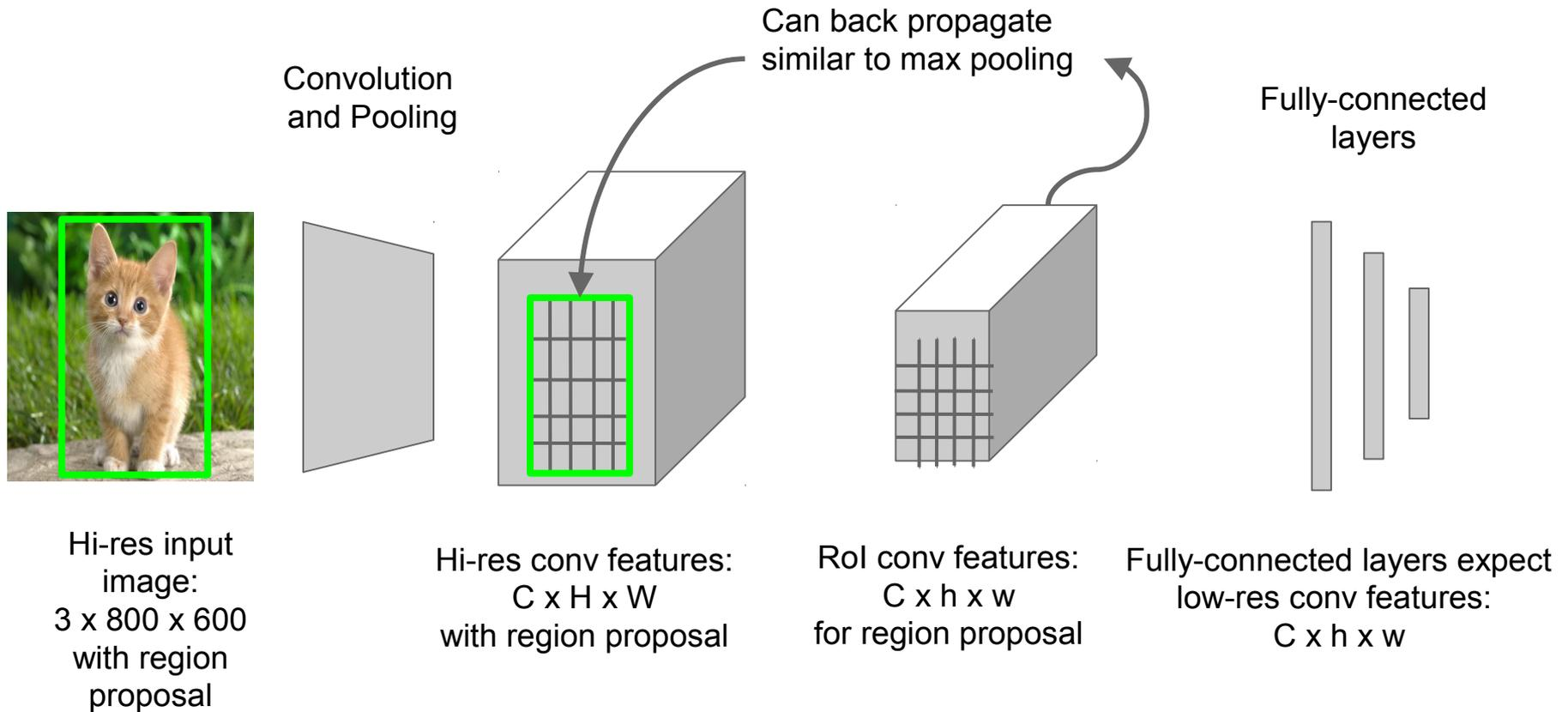

Fast R-CNN Results

Faster!

	R-CNN	Fast R-CNN
Training Time:	84 hours	9.5 hours
(Speedup)	1x	8.8x

Using VGG-16 CNN on Pascal VOC 2007 dataset

Fast R-CNN Results

	R-CNN	Fast R-CNN
Faster!		
Training Time:	84 hours	9.5 hours
(Speedup)	1x	8.8x
FASTER!		
Test time per image	47 seconds	0.32 seconds
(Speedup)	1x	146x

Using VGG-16 CNN on Pascal VOC 2007 dataset

Fast R-CNN Results

	R-CNN	Fast R-CNN
Faster!		
Training Time:	84 hours	9.5 hours
(Speedup)	1x	8.8x
FASTER!		
Test time per image	47 seconds	0.32 seconds
(Speedup)	1x	146x
Better!		
mAP (VOC 2007)	66.0	66.9

Using VGG-16 CNN on Pascal VOC 2007 dataset

Fast R-CNN Problem:

Test-time speeds don't include region proposals

	R-CNN	Fast R-CNN
Test time per image	47 seconds	0.32 seconds
(Speedup)	1x	146x
Test time per image with Selective Search	50 seconds	2 seconds
(Speedup)	1x	25x

Fast R-CNN Problem Solution:

Test-time speeds don't include region proposals
Just make the CNN do region proposals too!

	R-CNN	Fast R-CNN
Test time per image	47 seconds	0.32 seconds
(Speedup)	1x	146x
Test time per image with Selective Search	50 seconds	2 seconds
(Speedup)	1x	25x

Faster R-CNN:

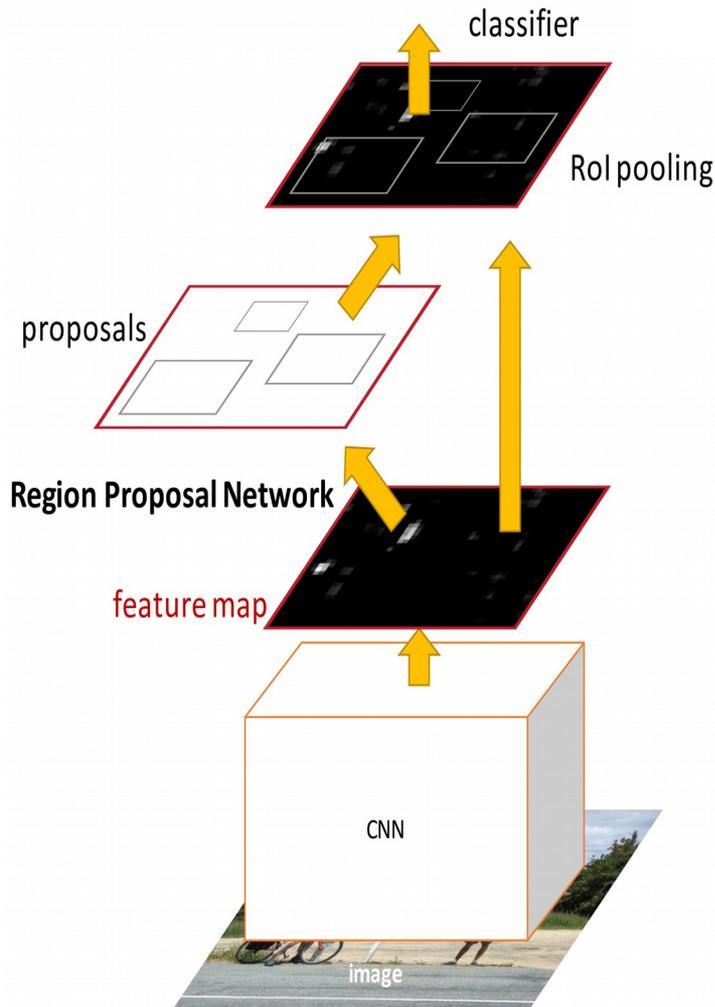

Insert a **Region Proposal Network (RPN)** after the last convolutional layer

RPN trained to produce region proposals directly; no need for external region proposals!

After RPN, use RoI Pooling and an upstream classifier and bbox regressor just like Fast R-CNN

Ren et al, "Faster R-CNN: Towards Real-Time Object Detection with Region Proposal Networks", NIPS 2015

Slide credit: Ross Girschick

Faster R-CNN: Region Proposal Network

Slide a small window on the feature map

Build a small network for:

- classifying object or not-object, and
- regressing bbox locations

Position of the sliding window provides localization information with reference to the image

Box regression provides finer localization information with reference to this sliding window

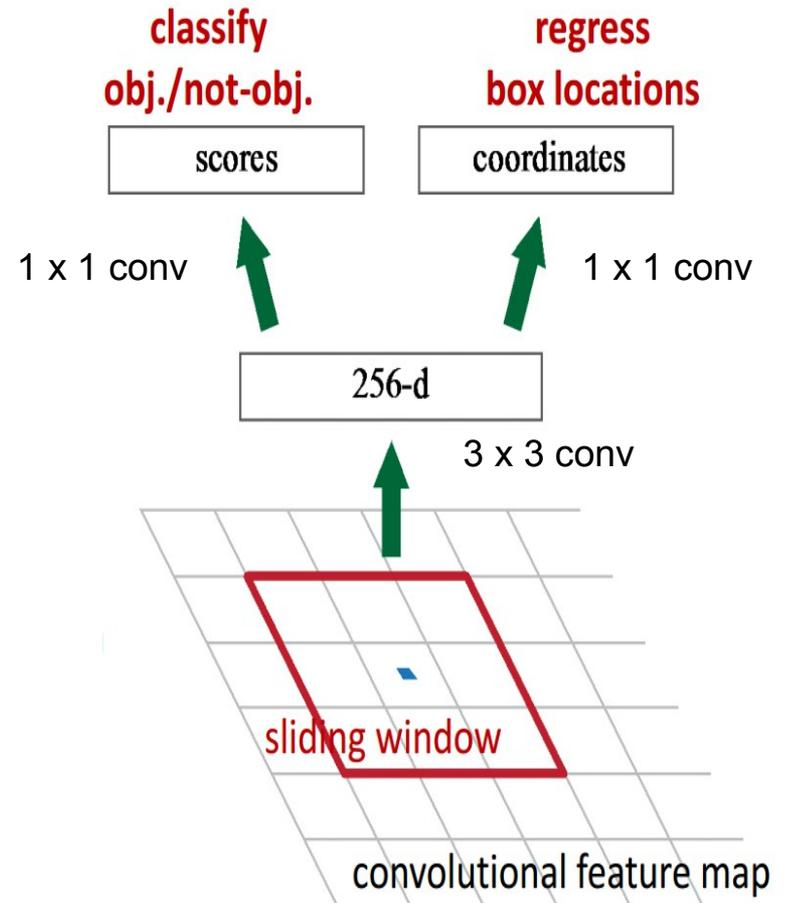

Slide credit: Kaiming He

Faster R-CNN: Region Proposal Network

Use N anchor boxes at each location

Anchors are **translation invariant**: use the same ones at every location

Regression gives offsets from anchor boxes

Classification gives the probability that each (regressed) anchor shows an object

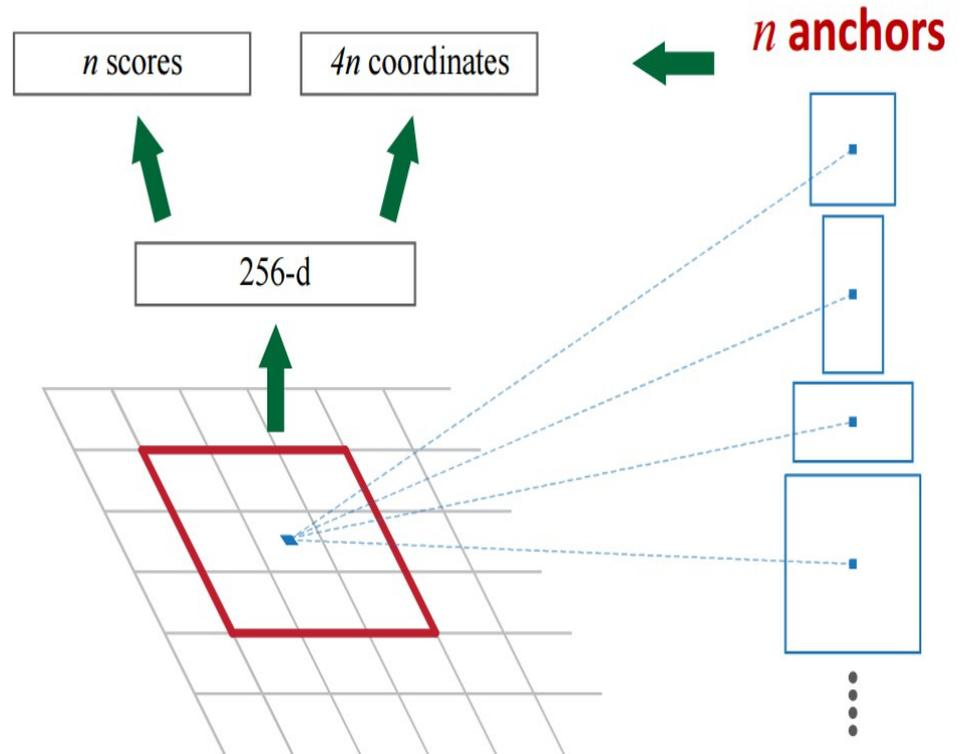

Faster R-CNN: Training

In the paper: Ugly pipeline

- Use alternating optimization to train RPN, then Fast R-CNN with RPN proposals, etc.
- More complex than it has to be

Since publication: Joint training!

One network, four losses

- RPN classification (anchor good / bad)
- RPN regression (anchor \rightarrow proposal)
- Fast R-CNN classification (over classes)
- Fast R-CNN regression (proposal \rightarrow box)

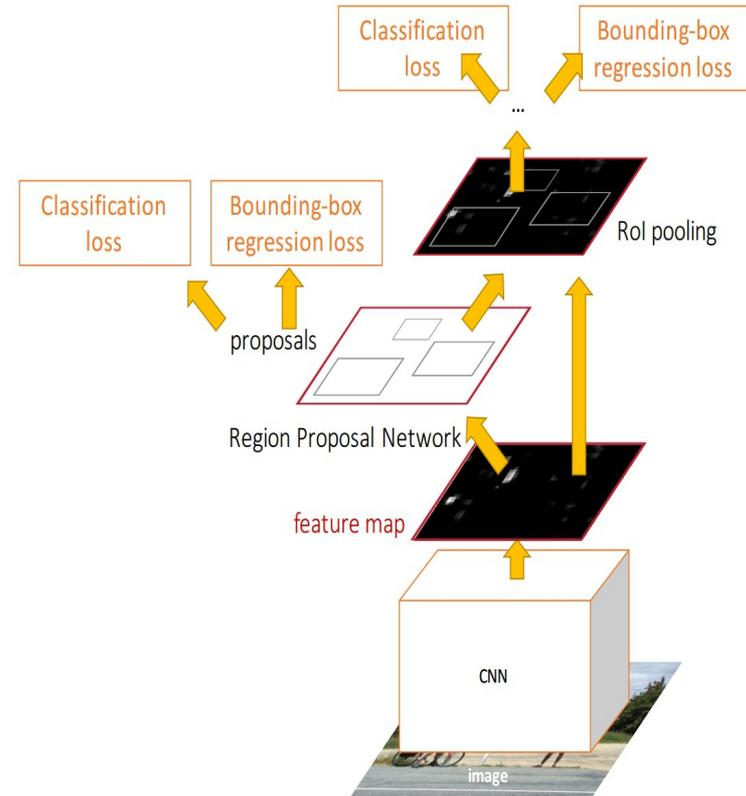

Slide credit: Ross Girschick

Faster R-CNN: Results

	R-CNN	Fast R-CNN	Faster R-CNN
Test time per image (with proposals)	50 seconds	2 seconds	0.2 seconds
(Speedup)	1x	25x	250x
mAP (VOC 2007)	66.0	66.9	66.9

Object Detection State-of-the-art: ResNet 101 + Faster R-CNN + some extras

training data	COCO train		COCO trainval	
test data	COCO val		COCO test-dev	
mAP	@.5	@[.5, .95]	@.5	@[.5, .95]
baseline Faster R-CNN (VGG-16)	41.5	21.2		
baseline Faster R-CNN (ResNet-101)	48.4	27.2		
+box refinement	49.9	29.9		
+context	51.1	30.0	53.3	32.2
+multi-scale testing	53.8	32.5	55.7	34.9
ensemble			59.0	37.4

He et. al, "Deep Residual Learning for Image Recognition", arXiv 2015

ImageNet Detection 2013 - 2015

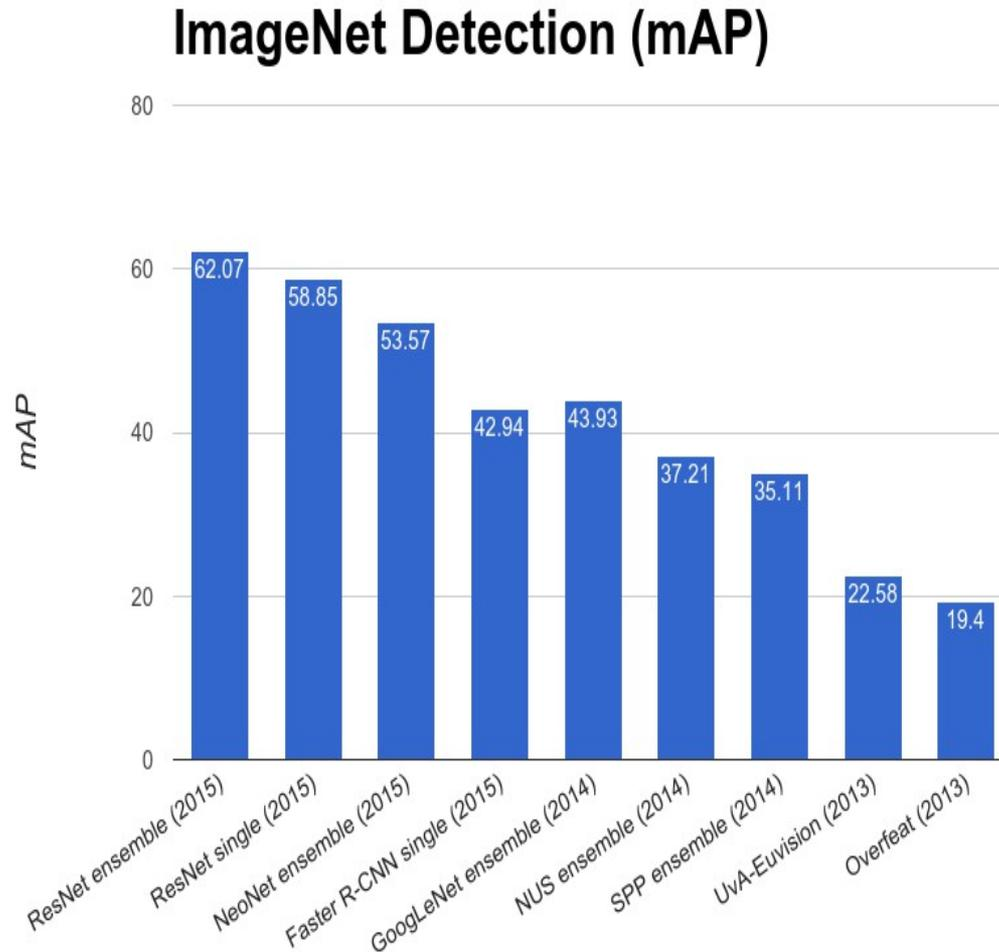

YOLO: You Only Look Once Detection as Regression

Divide image into $S \times S$ grid

Within each grid cell predict:

B Boxes: 4 coordinates + confidence

Class scores: C numbers

Regression from image to
 $7 \times 7 \times (5 * B + C)$ tensor

Direct prediction using a CNN

Redmon et al, "You Only Look Once:
Unified, Real-Time Object Detection", arXiv 2015

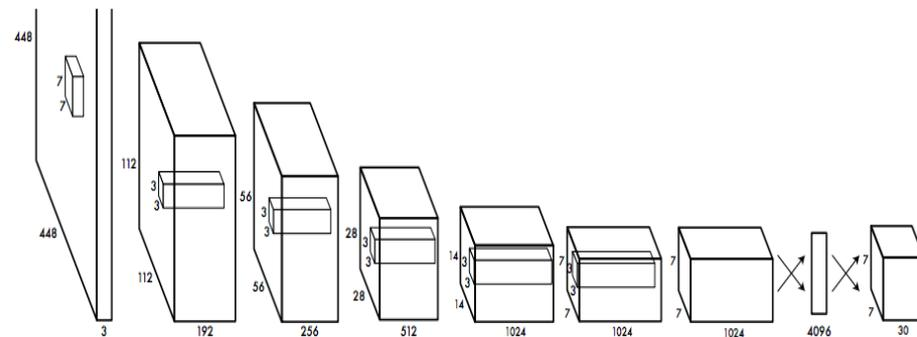
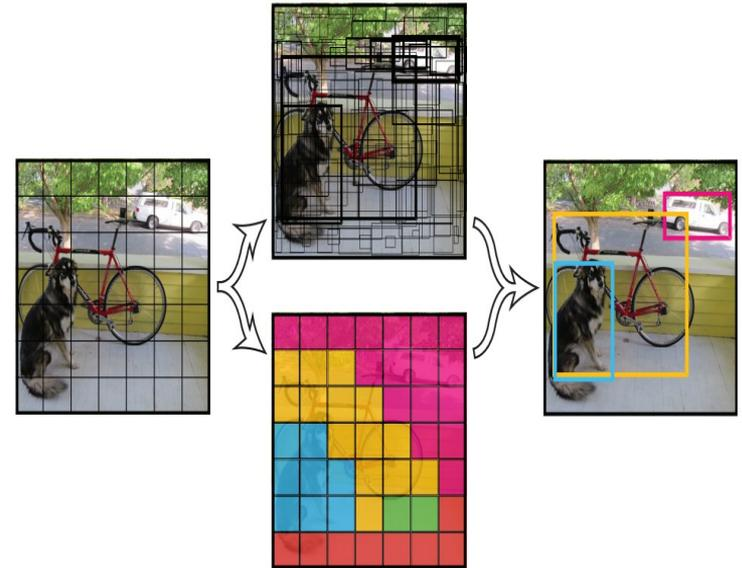

YOLO: You Only Look Once

Detection as Regression

Faster than Faster R-CNN, but not as good

Redmon et al, "You Only Look Once: Unified, Real-Time Object Detection", arXiv 2015

Real-Time Detectors	Train	mAP	FPS
100Hz DPM [30]	2007	16.0	100
30Hz DPM [30]	2007	26.1	30
Fast YOLO	2007+2012	52.7	155
YOLO	2007+2012	63.4	45
<hr/>			
Less Than Real-Time			
Fastest DPM [37]	2007	30.4	15
R-CNN Minus R [20]	2007	53.5	6
Fast R-CNN [14]	2007+2012	70.0	0.5
Faster R-CNN VGG-16[27]	2007+2012	73.2	7
Faster R-CNN ZF [27]	2007+2012	62.1	18