

Directed Graphs

Directed Graphs

Digraph. Set of objects with **oriented** pairwise connections.

Ex. One-way street, hyperlink.

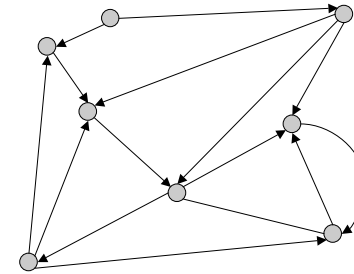

Reference: Chapter 19, Algorithms in Java, 3rd Edition, Robert Sedgewick.

Robert Sedgewick and Kevin Wayne · Copyright © 2005 · <http://www.Princeton.EDU/~cos226>

2

Digraph Applications

Digraph	Vertex	Edge
financial	stock, currency	transaction
transportation	street intersection, airport	highway, airway route
scheduling	task	precedence constraint
control flow	code block	jump
Internet	web page	hyperlink
game	board position	legal move
telephone	person	placed call
food web	species	predator-prey relation
infectious disease	person	infection
citation	journal article	citation
object graph	object	pointer
inheritance hierarchy	class	inherits from

Ecological Food Web

Food web graph.

- Vertex = species.
- Edge = from prey to predator.

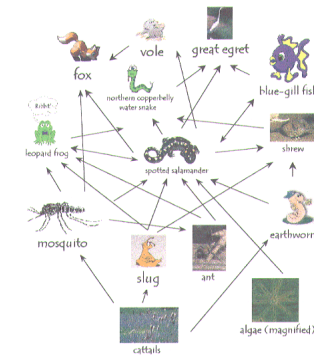

Reference: <http://www.twingroves.district96.k12.il.us/Wetlands/Salamander/SalGraphics/salfoodweb.gif>

3

4

Some Digraph Problems

Transitive closure. Is there a directed path from v to w ?

Strong connectivity. Are all vertices mutually reachable?

Topological sort. Can you draw the graph so that all of the edges point from left to right?

PERT/CPM. Given a set of tasks with precedence constraints, what is the earliest that we can complete each task?

Shortest path. Given a weighted graph, find best route from v to w ?

PageRank. What is the importance of a web page?

Digraph Representation

Vertex names.

- This lecture: use integers between 0 and $v-1$.
- Real world: convert between names and integers with symbol table.

Orientation of edge matters.

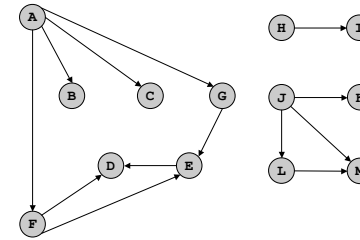

5

6

Adjacency Matrix Representation

Adjacency matrix representation.

- Two-dimensional $v \times v$ boolean array.
- Edge $v \rightarrow w$ in graph: $\text{adj}[v][w] = \text{true}$.

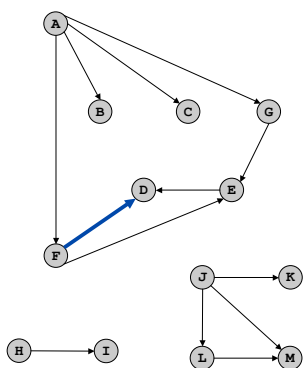

		A	B	C	D	E	F	G	H	I	J	K	L	M
0	A	0	1	1	0	0	1	1	0	0	0	0	0	0
1	B	0	0	0	0	0	0	0	0	0	0	0	0	0
2	C	0	0	0	0	0	0	0	0	0	0	0	0	0
3	D	0	0	0	0	0	0	0	0	0	0	0	0	0
4	E	0	0	0	1	0	0	0	0	0	0	0	0	0
5	F	0	0	0	1	1	0	0	0	0	0	0	0	0
6	G	0	0	0	0	1	0	0	0	0	0	0	0	0
7	H	0	0	0	0	0	0	0	0	1	0	0	0	0
8	I	0	0	0	0	0	0	0	0	0	0	0	0	0
9	J	0	0	0	0	0	0	0	0	0	0	1	1	1
10	K	0	0	0	0	0	0	0	0	0	0	0	0	0
11	L	0	0	0	0	0	0	0	0	0	0	0	0	1
12	M	0	0	0	0	0	0	0	0	0	0	0	0	0

7

Adjacency List Representation

Vertex indexed array of lists.

- Space proportional to number of edges.
- One representation of each edge.

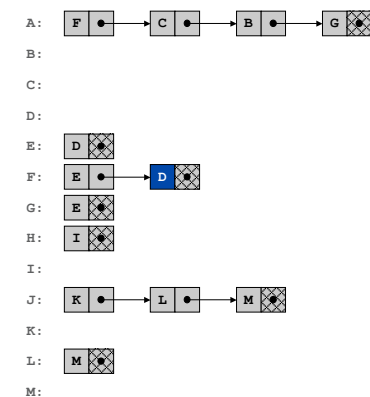
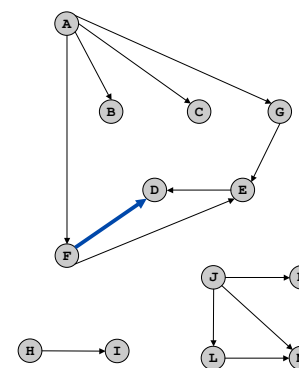

8

Implementation. Same as Graph, but only insert one copy of each edge.

```
public class Digraph {
    private int V;
    private Sequence<Integer>[] adj;

    public Digraph(int V) {
        this.V = V;
        adj = (Sequence<Integer>[]) new Sequence[V];
        for (int v = 0; v < V; v++)
            adj[v] = new Sequence<Integer>();
    }

    public void insert(int v, int w) {
        adj[v].add(w);
    }

    public Iterable<Integer> adj(int v) {
        return adj[v];
    }
}
```

9

Digraph Search

Digraphs are abstract mathematical objects.

- ADT implementation requires specific representation.
- Efficiency depends on matching algorithms to representations.

Representation	Space	Edge from v to w?	Enumerate edges leaving v?
List of edges	$\Theta(E + V)$	$O(E)$	$\Theta(E)$
Adjacency matrix	$\Theta(V^2)$	$\Theta(1)$	$\Theta(V)$
Adjacency list	$\Theta(E + V)$	$O(\text{outdeg}(v))$	$\Theta(\text{outdeg}(v))$

Digraphs in practice. [use adjacency list representation]

- Real world digraphs are sparse.
- Bottleneck is iterating over edges leaving v.

10

Reachability

Goal. Find all vertices reachable from s along a directed path.

Depth first search. To visit a vertex v:

- Mark v as visited.
- Recursively visit all unmarked vertices w adjacent to v.



Running time. $O(E)$ since each edge examined at most once.

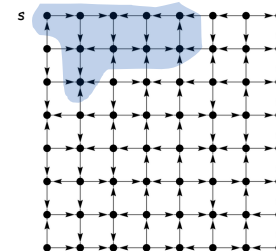

Depth First Search

Remark. Same as undirected version, except `Digraph` instead of `Graph`.

```
public class DFSearcher {
    private boolean[] marked;

    public DFSearcher(Digraph G, int s) {
        marked = new boolean[G.V()];
        dfs(G, s);
    }

    private void dfs(Digraph G, int v) {
        marked[v] = true;
        for (int w : G.adj(v))
            if (!marked[w]) dfs(G, w);
    }

    public boolean isReachable(int v) { return marked[v]; }
}
```

13

Mark-Sweep Garbage Collector

Roots. Objects known to be accessible by program (e.g., stack).

Live objects. Objects that the program could get to by starting at a root and following a chain of pointers.

← easy to identify pointers in type-safe language

Mark-sweep algorithm. [McCarthy 1960]

- Mark: run DFS from roots to mark live objects.
- Sweep: if object is unmarked, it is garbage, so add to free list.

Extra memory. Uses 1 extra mark bit per object, plus DFS stack.

15

Control Flow Graph

Control-flow graph.

- Vertex = basic block (straight-line program).
- Edge = jump.

Dead code elimination. Find (and remove) code blocks that are unreachable during execution.

← dead code might arise from compiler optimizations
(or careless programmer)

Infinite loop detection. Exit block is unreachable from entry block.

Caveat. Not all infinite loops are detectable.

14

Depth First Search

DFS enables direct solution of simple digraph problems.

- Reachability.
- Cycle detection.
- Topological sort.
- Transitive closure.
- Find path from s to t .

Basis for solving difficult digraph problems.

- Directed Euler path.
- Strong connected components.

16

Breadth First Search

Shortest path. Find the shortest directed path from s to t .

BFS. Analogous to BFS in undirected graphs.

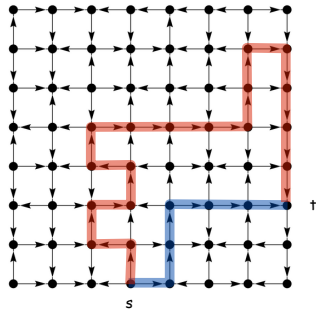

17

Application: Web Crawler

Web graph. Vertex = website, edge = hyperlink.

Goal. Crawl Internet, starting from some root website.

Solution. BFS with implicit graph.

BFS.

- Start at some root website, say `http://www.princeton.edu`.
- Maintain a `Queue` of websites to explore.
- Maintain a `SET` of discovered websites.
- Dequeue the next website, and enqueue websites to which it links (provided you haven't done so before).

Q. Why not use DFS?

18

Web Crawler: Java Implementation

```
Queue<String> q = new Queue<String>(); ← queue of sites to crawl
SET<String> visited = new SET<String>(); ← set of visited sites
String s = "http://www.princeton.edu";
q.enqueue(s);
visited.add(s);
while (!q.isEmpty()) {
    String v = q.dequeue();
    System.out.println(v);
    In in = new In(v);
    String input = in.readAll();
    String regexp = "http://(\\w+\\.)* (\\w+)";
    Pattern pattern = Pattern.compile(regexp);
    Matcher matcher = pattern.matcher(input);
    while (matcher.find()) { ← search using regular expression
        String w = matcher.group();
        if (!visited.contains(w)) {
            visited.add(w); ← if unvisited, mark as visited
            q.enqueue(w); ← and put on queue
        }
    }
}
```

19

Transitive Closure

Transitive Closure

Transitive closure. Is there a directed path from v to w ?

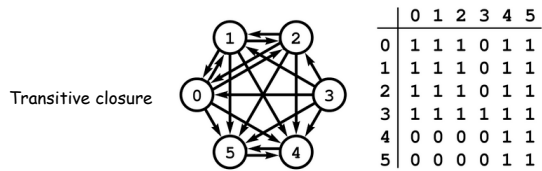
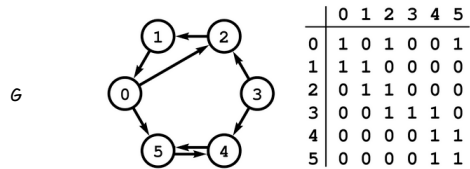

$tc[v][w] = 1$ iff path from v to w

21

Transitive Closure

Transitive closure. Is there a directed path from v to w ?

Lazy. Run separate DFS for each query.

Eager. Run DFS from every vertex v .

Method	Preprocess	Query	Space
DFS (lazy)	$O(1)$	$O(E + V)$	$O(E + V)$
DFS (eager)	$O(EV)$	$O(1)$	$O(V^2)$

Remark. Directed problem is harder than undirected one.

Open research problem. $O(1)$ query, $O(V^2)$ preprocessing time.

22

Transitive Closure: Java Implementation

```
public class TransitiveClosure {
    private boolean[][] tc;

    public TransitiveClosure(Digraph G) {
        tc = new boolean[G.V()][G.V()];
        for (int v = 0; v < G.V(); v++)
            dfs(G, v, v);
    }
    // run dfs from every vertex

    // reachability from s, made it to v
    private void dfs(Digraph G, int s, int v) {
        tc[s][v] = true;
        for (int w : G.adj(v))
            if (!tc[s][w]) dfs(G, s, w);
    }

    public boolean reachable(int v, int w) { return tc[v][w]; }
    // is w reachable from v?
}
```

23

Topological Sort

Topological Sort

DAG. Directed acyclic graph.

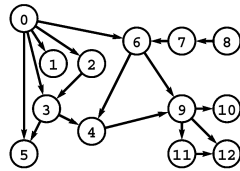

Topological sort. Redraw DAG so all edges point left to right.

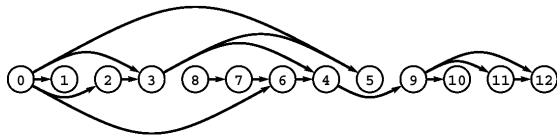

Observation. Not possible if graph has a directed cycle.

Application: Scheduling

Scheduling. Given a set of tasks to be completed with precedence constraints, in what order should we schedule the tasks?

Graph model.

- Create a vertex v for each task.
- Create an edge $v \rightarrow w$ if task v must precede task w .
- Schedule tasks in topological order.

0. read programming assignment
1. download files
2. write code
- ...
12. sleep

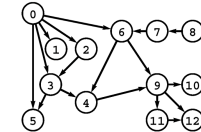

25

26

Topological Sort: DFS

Topologically sort a DAG.

- Run DFS.
- Reverse postorder numbering yields a topological sort.



Pf of correctness. When DFS backtracks from a vertex v , all vertices reachable from v have already been explored.

Running time. $O(E + V)$.

no back edges in DAG

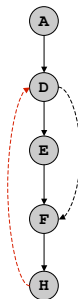

DFS tree

Q. If not a DAG, how would you identify a cycle?

Topological Sort: Java Implementation

```
public class TopologicalSorter {
    private int cnt;
    private boolean[] visited;
    private int[] ts;

    public TopologicalSorter(Digraph G) {
        visited = new boolean[G.V()];
        ts = new int[G.V()];
        cnt = G.V();
        for (int v = 0; v < G.V(); v++)
            if (!visited[v]) tsort(G, v);
    }

    private void tsort(Digraph G, int v) {
        visited[v] = true;
        for (int w : G.adj(v))
            if (!visited[w]) tsort(G, w);
        ts[--cnt] = v;
    }
}
// assign numbers in reverse DFS postorder
```

27

28

Topological Sort: Applications

Topological sort applications.

- Causalities.
- Compilation units.
- Class inheritance.
- Course prerequisites.
- Deadlocking detection.
- Temporal dependencies.
- Pipeline of computing jobs.
- Check for symbol link loop.
- Evaluate formula in spreadsheet.

Program Evaluation and Review Technique / Critical Path Method

PERT/CPM.

- Task v takes $\text{time}[v]$ units of time.
- Can work on jobs in parallel.
- Precedence constraints: must finish task v before beginning task w .
- What's earliest we can finish each task?

Index	Task	Time	Prereq
A	Begin	0	-
B	Framing	4	A
C	Roofing	2	B
D	Siding	6	B
E	Windows	5	D
F	Plumbing	3	D
G	Electricity	4	C, E
H	Paint	6	C, E
I	Finish	0	F, H

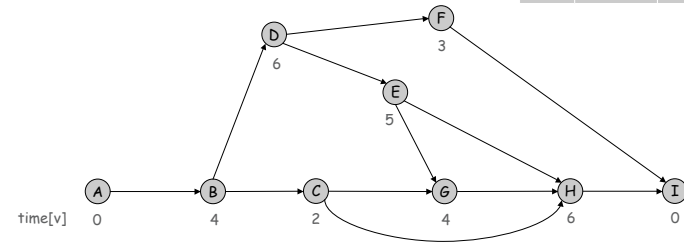

29

30

Program Evaluation and Review Technique / Critical Path Method

PERT/CPM algorithm.



- Compute topological order of vertices.
- Initialize $\text{fin}[v] = 0$ for all vertices v .
- Consider vertices v in topological order.
 - for each edge $v \rightarrow w$, set $\text{fin}[w] = \max(\text{fin}[w], \text{fin}[v] + \text{time}[w])$

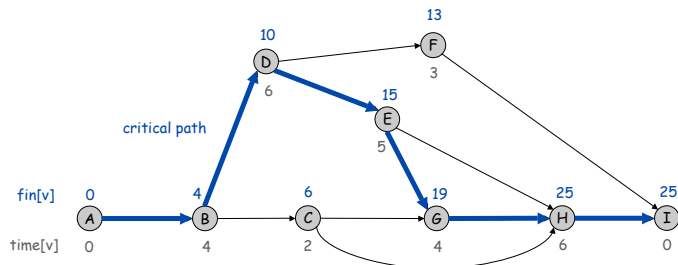

31